



www.snapon-bluepoint.com

Blue-Point is a trademark of Snap-on Incorporated. © Snap-on Incorporated 2011.

BPCAT1200

Blue-Point®

2012

www.snapon-bluepoint.com

Blue-Point, No Compromise!

LIFETIME WARRANTY

A large, 3D-rendered blue pen nib is shown in a dynamic, angled perspective. The Blue-Point logo is embossed on the side of the nib, appearing to glow with light. The background is a deep blue with faint technical drawings of mechanical parts and glowing light trails, creating a sense of precision and technology.

History of Blue-Point

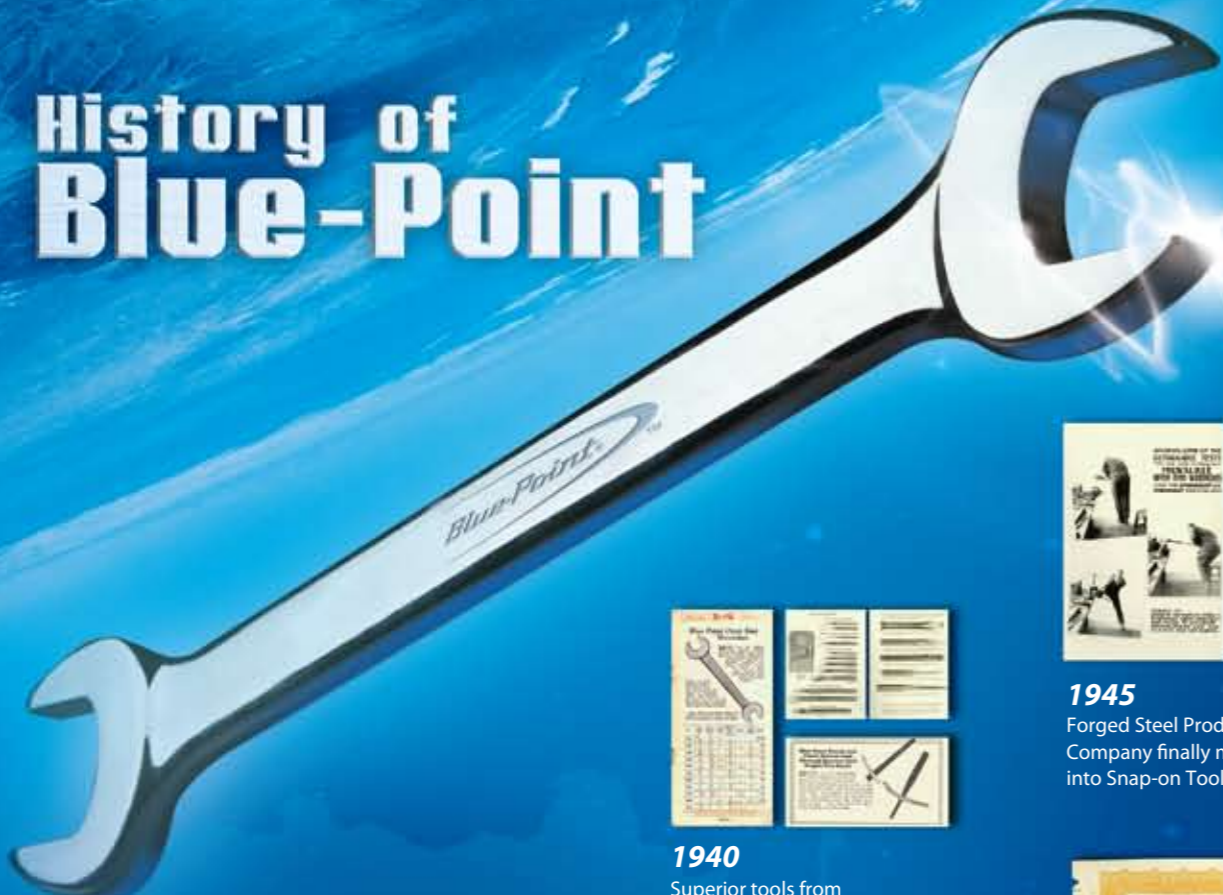

1940
Superior tools from Snap-on, Inc. Making headlines in the industry



1925
Blue Point Tool Company was formed



1945
Forged Steel Products Company finally merged into Snap-on Tools, Inc.



1930
Snap-on Wrench Company and Blue Point Tool Company merged to become Snap-on Tools, Inc.

Founded in 1925, Blue Point Tool Company was formed in Wisconsin, United States, as a tools manufacturing company. The Blue Point name was derived then from the blue-coloured tip of punches & chisels formed after oil quenching and tempering. This distinguished Blue Point's products from competitors' and Blue Point eventually became a brand synonymous with quality hand tools.

Following the successful introduction of the Blue Point punches and chisels, the management turned to their Milwaukee supplier factory to provide open end wrenches and issued this order: "Forget competition, forget price, forget precedent; just take our order to make the best wrench in the world, and we will sell them regardless of competition and regardless of price." A short time later the factory delivered their first set of eight open end wrenches and guaranteed that it was IMPOSSIBLE - to break the head; to spread the jaws; to bend the handle; to injure them; or, to destroy their everlasting efficiency. That sounded like a pretty wild and extravagant claim, but the sales force set out to sell them on that basis...and sell them they did!



Contents



TOOL STORAGE

- Roll Cabinets
- Roll Carts
- Tool Boxes

1-7



MASTER TOOL SETS

- General Service Sets
- Automotive Tool Sets

8-15



SOCKETS, RATCHETS & ACCESSORIES

- 1/4"
- 3/8"
- 1/2"
- 3/4"

16-33



WRENCHES

- Wrench Sets
- Double Open End Wrenches
- T and L shape Wrenches
- Adjustable Wrenches
- Offset Wrenches
- Other Wrenches
- Combination Wrenches
- Ratcheting Wrenches

34-43



SCREWDRIVERS & BITS

- Screwdrivers
- Bits

44-49



PLIERS

- Plier Sets
- Locking Pliers
- Standard Pliers
- Retaining Ring Pliers
- VDE Pliers
- Special Pliers

50-63



TORQUE TOOLS

- Adjustable Click-Type
- Electronic Type
- Preset Click-Type
- Digital Torque Testers

64-69



POWER TOOLS

- Air Tools
- Impact Sockets
- Cordless Tools
- Accessories

70-97



STRIKING & CUTTING

- Hammers
- Punches & Chisels
- Cutting Tools

98-107



MEASURING & OTHER HAND TOOLS

- Measuring Tools
- Safety
- Flashlights
- Miscellaneous

108-123



SHOP & TECHNICIAN TOOLS

- Testing and Electronics
- Automotive Specialty Tools
- Special Tools

124-153



SHOP EQUIPMENT

- Shop Equipment

154-159

For more information about Blue-Point products
Goto: www.snapon-bluepoint.com



Tool Storage



Getting organized for the job gives you more than you may have realized. You can be sure that tools you need are readily available. The work space gets less messy and you focus better. No more searching of tools all over and replacement of missing tools. Time is spent more productively and work is done more efficiently. End of the day, you feel better and you look forward to your day's work, with your tools.

Professionals have long realized that and they work with pride. And we have been providing the exact tool storage they require to make this possible. Our tool storage are designed with the latest computer-aided design systems and built to last the daily knocks of the work environment they are put into. Our paint and finishing systems deliver the finest, most durable finishes available and our rigorous testing ensures a trouble free lifetime of service.



Roll Cabinets	2
Roll Carts	4
Tool Boxes	5

6 Drawers Roll Cab

Order NO.: 101009

KRB2006KPQP



Colors Available KRB2006KPQR **Order NO.: 101010**

	Cubic (cm ³)	Net Weight (kg)	Shipping Weight (kg)		
	156,791	75	95		
Specifications	Drawers	Width (mm)	Depth (mm)	Height (mm)	
	6	660	503	965	
	5	544	445	91	
Drawers	1	544	445	193	

- Full double walled construction making for a stronger box which resists the constant pounding of weight and vibration
- Stiffeners are added between the walls to reduce stress on the box and keep the drawers from sagging
- Welded lock tabs on the back of each drawer
- Casters are fastened to the roll cab using weld nuts so they won't loosen over time
- Drawer edges are hemmed to double thickness so they are extra stiff

8 Drawers Roll Cab

Order NO.: 101007

KRB13008KPRB



Colors Available KRB13008KPRR **Order NO.: 101008**

	Cubic (cm ³)	Net Weight (kg)	Shipping Weight (kg)		
	168,059	110	129		
Specifications	Drawers	Width (mm)	Depth (mm)	Height (mm)	
	8	1016	501	961	
Drawers	5	543	445	119	
	1	543	445	250	
Cabinet Drawers	2	284	445	40	

- 40" double bank roll cab, greater capacity
- Double-wall design for a more rigid tool box
- Welded lock tabs on the back of each drawer
- Popular choice with side cabinet for your work center
- Full double walled construction making for a stronger box which resists the constant pounding of weight and vibration
- Stiffeners are added between the walls to reduce stress on the box and keep the drawers from sagging

5 Drawers Roll Cab

Order NO.: 101005

KRB13005KPRB



Colors Available KRB13005KPRR **Order NO.: 101006**

	Cubic (cm ³)	Net Weight (kg)	Shipping Weight (kg)		
	159,387	61	68		
Specifications	Drawers	Width (mm)	Depth (mm)	Height (mm)	
	5	677	501	822	
Drawers	1	543	445	54	
	2	543	445	119	
	2	543	445	184	

- High grade steel plate with DuPont PE Powder painting for better flowing property to avoid peel
- 45 kg slider with fully-openable drawers
- Bigger sized with greater capacity at 508 kg
- Tubular lock-stronger over molded key lock
- Ribs added for enhanced strength to prevent cabinet deformation

6 Drawers Roll Cab

Order NO.: 101003

KRB13006KPRB



Colors Available KRB13006KPRR **Order NO.: 101004**

	Cubic (cm ³)	Net Weight (kg)	Shipping Weight (kg)		
	156,536	65	72		
Specifications	Drawers	Width (mm)	Depth (mm)	Height (mm)	
	6	677	501	822	
Drawers	3	543	445	54	
	2	543	445	119	
	1	543	445	250	

8 Drawers Roll Cab

Drawers made using 20 AWG steel

Lock & Roll mechanism to prevent drawers from sliding open

Railings withstanding 45kg per rail with roller bearings for smoother sliding of drawers

Drawer edges are hemmed to double thickness to be extra stiff

Cabinet door edges are folded to form a seamless fit without gaps when closed; Cabinets walls reinforced with stiffeners to provide extra strength

Reinforced base design to withstand higher overall load and reduce sagging

Casters are fastened to the roll cab using weld nuts so they won't loosen over time

7 Drawers Roll Cab

Order NO.: 101001

KRB13007KPRB



Colors Available KRB13007KPRR **Order NO.: 101002**

	Cubic (cm ³)	Net Weight (kg)	Shipping Weight (kg)		
	153,695	68	75		
Specifications	Drawers	Width (mm)	Depth (mm)	Height (mm)	
	7	677	501	822	
Drawers	5	543	445	54	
	1	543	445	119	
	1	543	445	250	

- High grade steel plate with DuPont PE Powder painting for better flowing property to avoid peel
- 45 kg slider with fully-openable drawers
- Bigger sized with greater capacity at 508 kg
- Tubular lock-stronger over molded key lock
- Ribs added for enhanced strength to prevent cabinet deformation

5 Drawers Top Chest

Order NO.: 101011

KRB2055KPQP



Colors Available KRB2055KPQR **Order NO.: 101012**

	Cubic (cm ³)	Net Weight (kg)	Shipping Weight (kg)		
	72,824	38	44		
Specifications	Drawers	Width (mm)	Depth (mm)	Height (mm)	
	5	660	374	437	
Drawers	4	566	334	47	
	1	566	334	79	

- Can be placed on all Blue-Point roll-cabs as a top chest
- Lockable top lid
- Side grooves for easy lifting

2 Shelves Roll-Cart

Order NO.: 102001

KRBC2TPCM



Colors Available KRBC2TC Order NO.: 102002

	Net Weight (kg)	Load Capacity (kg)		
	38	159		
Specifications	Drawers	Width (mm)	Depth (mm)	Height (mm)
	—	756	428	920
Trays	—	756	428	75

- This newer model cart offers a more rugged construction
- Cart is also slightly larger than past models
- Trays feature rolled edges for improved strength and rigidity
- Maximum load capacity 68kg per tray
- Welded post holders
- Two locking casters

2 Shelves Roll-Cart

Order NO.: 102003

KRBC3TDCM



Colors Available KRBC3TD Order NO.: 102004

	Net Weight (kg)	Load Capacity (kg)		
	65	136		
Specifications	Drawers	Width (mm)	Depth (mm)	Height (mm)
	1	813	452	920
Trays	—	762	686	102
Drawer	1	368	686	102

- Features 4" deep locking drawer with tubular lock for added tool security
- Two sturdy, 3" deep trays are positioned for convenience
- Friction drawer slides
- Made of heavy-gauge steel

4 Drawers Flip-Top Roll-Cart

Order NO.: 102005

KRBC7TDCM



Colors Available KRBC7TD Order NO.: 102006

	Net Weight (kg)	Load Capacity (kg)		
	50.8	—		
Specifications	Drawers	Width (mm)	Depth (mm)	Height (mm)
	4	889	431	1,041
Drawers	2	350	399	51
	1	700	391	51
	1	700	391	102
Bottom Shelf	1	700	391	76

- NEW Latch System to unlock all 4 drawers once the top lid has been opened with a key
- Folding side work shelf provides extra work space
- Padded lid provides an additional work surface
- Locking prybar compartment securely holds all length prybars and screwdrivers

4 Drawers Flip-Top Roll-Cart

Order NO.: 102007

KRBC10TBPCM



Colors Available KRBC10TB Order NO.: 102008

	Cubic (cm ³)	Load Capacity (kg)		
	121,700	245		
Specifications	Drawers	Width (mm)	Depth (mm)	Height (mm)
	4	775	520	1,048
Drawers	2	292	445	64
	1	622	445	64
	1	622	445	64
Bottom Shelf	2	762	483	89
Top Compartment	—	762	483	64

- Auto locking mechanism locks drawers when lid is closed
- Plated fasteners resist corrosion and self locking nuts assure a rigid, secure assembly
- Non-toxic mats in shelf, drawers and top compartment protect unit and keep tools from sliding

4 Drawers Sliding Top Roll-Cart

Order NO.: 102009

KRBCSSTPCM



Colors Available KRBCSST Order NO.: 102010

	Cubic (cm ³)	Net Weight (kg)	Load Capacity (kg)		
	261,062	56	136		
Specifications	Drawers	Width (mm)	Depth (mm)	Height (mm)	
	2	747	524	982	
Top Compartment	—	747	524	172	
Drawers	2	745	445	69	
Bottom Shelf	—	745	445	76	

- Padded lid protects finish and provides additional work surface
- Roller bearing slide drawers, locking slide top, internal prybar holder
- Dual locking casters keep cart in place during use

4 Drawers Flip-Top Roll-Cart

Order NO.: 102011

KRBC30TPCM



Colors Available KRBC30T Order NO.: 102012

	Net Weight (kg)	Load Capacity (kg)		
	84	363		
Specifications	Drawers	Width (mm)	Depth (mm)	Height (mm)
	4	889	533	1,048
Top Compartment	—	610	38	76
	1	610	965	279
Drawer	1	610	965	127
	2	610	965	51

- Portable 20 foot electrical cord reel with 4 outlets and circuit breakers
- Adjustable personal organizer tray in top compartment
- Bottom corner bump blocks for extra corner protection
- Larger pull handles for easy drawer opening
- Sturdy side work table

2 Drawers Flip-Top Roll-Cart

Order NO.: 102013

KRBC15TPCM



*Shown here with optional top chest KRBC15TPCMTC not included

Colors Available KRBC15T Order NO.: 102014

	Net Weight (kg)	Load Capacity (kg)		
	40	136		
Specifications	Drawers	Width (mm)	Depth (mm)	Height (mm)
	4	671	465	1,077
Trays	—	660	300	112
Drawer	2	572	386	97
Bottom Shelf	1	667	456	331

- Padded lid protects finish and provides additional work surface
- Removable top chest locks to cart
- Two roller bearing slide drawers on both the top chest and cart
- EVA liners in all drawers and bottom compartment

2 Drawers Top Chest

Order NO.: 102015

KRBC15TPCMTC



Colors Available KRBC15TTC Order NO.: 102016

	Cubic (cm ³)	Shipping Weight (kg)		
	40,624	24		
Specifications	Drawers	Width (mm)	Depth (mm)	Height (mm)
	2	660	304	280
Top Compartment	—	660	300	112
Drawer	2	61	569	267

- Padded lid protects finish and provides additional work surface
- Gas shock for safe closure
- Removable top chest locks to cart
- Two roller bearing slide drawers
- EVA liners in all drawers

Roll Cab Tops

Order NO.: 103014



Stock No.	Size (mm)	Description	Packing	Order No.
SKRWT4008	660	wooden top	1	101013
SKRWT4008B	1016	wooden top	1	101014
SKRSST4107	1016	stainless steel top	1	101015

- For use with all Blue-Point roll-cabs of respective sizes (KRB13008KPRB/R uses 1016mm, other models use 660mm)

Plastic Tool Box 18"

Order NO.: 103014

BPBOX18



Length (mm)	Width (mm)	Height (mm)
445	240	206

- Steel pins for extra durable usage, connecting the lid and the box
- Strong Handle and lock Material
- Separate top tray to hold small tools

Tool Bag 17"

Order NO.: 103001

BPTOTE



Length (mm)	Width (mm)	Height (mm)
419	267	311

- Rugged and versatile
- Constructed from heavy duty 600 x 300D polyester
- Water resistant
- Embroidered Blue-Point® logo
- Wide top opening for easy access
- Multiple interior and external pockets for tool organization

Tool Box 18"
Order NO.: 103002

KRW48C



Cubic (cm ³)	Dimensions (mm)
25,070	457 x 254 x 337

- Split top opening for tool access
- Cantilever trays on either side of cover, carrying handle

Tool Box 21"
Order NO.: 103003

KRU24B



Cubic (cm ³)	Dimensions (mm)
41,623	Trays: 546 x 117 x 36 Bottom Section: 599 x 295 x 184 Overall: 610 x 305 x 305

- Rugged construction featuring reinforced feet formed cantilever bars and larger hasps for strength in use
- Comfortable, recessed soft grip handle permits stacking of kits or other items in transit
- Cantilever design allows immediate visibility and access to all your tools
- Huge bottom section holds large items, such as power tools and larger hand tools
- Lightweight: 12.3 kg

Tool Box 18", 2 Drawers
Order NO.: 103004

KRW182B



Cubic (cm ³)	Dimensions (mm)
18,630	470 x 216 x 241

- Net weight: 5.67 kg
- Shipping weight: 6.58 kg

Tool Box 20", 3 Drawers
Order NO.: 103005

KRW183C



Cubic (cm ³)	Dimensions (mm)
26,830	Overall: 523 x 216 x 305 Each Drawer: 452 x 186 x 64

- Drawers lock when lid is closed
- Net weight: 9.07 kg

Tool Box 20", 4 Drawers
Order NO.: 103006

KRW184B



Cubic (cm ³)	Dimensions (mm)
30,330	Overall: 523 x 216 x 362 Each Drawer: 452 x 186 x 64

- Four drawers lock when lid is closed
- Tote tray not included
- Net weight: 11.07 kg

Plastic Tool Box 16"
Order NO.: 103007

KRW200A



Length (mm)	Width (mm)	Height (mm)
413	254	318

- Ideal for a wide range of storage needs
- Made of tough, injection molded plastic to ensure a precise fitting lid and durability
- Top carrying handle, tension latches, tote tray, and padlock provision are also featured

Plastic Tool Box 20"
Order NO.: 103008

KRW300A



Length (mm)	Width (mm)	Height (mm)
527	343	425

- Ideal for a wide range of storage needs
- Made of tough, injection molded plastic to ensure a precise fitting lid and durability
- Top carrying handle, tension latches, tote tray, and padlock provision are also featured

Plastic Tool Box 15"
Order NO.: 103009

YA481



Length (mm)	Width (mm)	Height (mm)
368	184	114

- Ideal for a wide range of storage needs
- YA481 through YA486 are made of tough, injection molded plastic to ensure a precise fitting lid and durability
- Top carrying handle, tension latches, tote tray, and padlock provision are also featured

Plastic Tool Box 16"
Order NO.: 103010

YA482



Length (mm)	Width (mm)	Height (mm)
419	210	165

- Ideal for a wide range of storage needs
- YA481 through YA486 are made of tough, injection molded plastic to ensure a precise fitting lid and durability
- Top carrying handle, tension latches, tote tray, and padlock provision are also featured

Plastic Tool Box 20"
Order NO.: 103011

YA483



Length (mm)	Width (mm)	Height (mm)
514	229	197

- Ideal for a wide range of storage needs
- YA481 through YA486 are made of tough, injection molded plastic to ensure a precise fitting lid and durability
- Top carrying handle, tension latches, tote tray, and padlock provision are also featured

Plastic Tool Box 23"
Order NO.: 103012

YA484



Length (mm)	Width (mm)	Height (mm)
587	260	267

- Ideal for a wide range of storage needs
- YA481 through YA486 are made of tough, injection molded plastic to ensure a precise fitting lid and durability
- Top carrying handle, tension latches, tote tray, and padlock provision are also featured

Plastic Tool Box 27"
Order NO.: 103013

YA486



Length (mm)	Width (mm)	Height (mm)
699	340	356

- Ideal for a wide range of storage needs
- YA481 through YA486 are made of tough, injection molded plastic to ensure a precise fitting lid and durability
- Top carrying handle, tension latches, tote tray, and padlock provision are also featured



Master Tool Sets



Our tool sets comprise of quality tools each carefully selected to suit applications that the set is created for.

Every set is designed to avoid duplication of tools so that you can get a series of tool sets that are complimentary without having too many of the same tools.

Likewise, the tools in each set have been streamlined to cater more accurately to the task and environment it has been created for so you do not pay for tools you will not need.

You will likely find a set that fits your needs in our growing range of tool sets catered to meet today's most commonly faced applications.

General Service Sets	10
Automotive Tool Sets	14

1/4" & 3/8" Drive Socket Set, 155pcs

Order NO.: 201001

BLPGSSC155



Set Components (1/4" Drive):

- 10 fractional (3/16" to 9/16") and 13 metric (4 to 14mm) standard sockets
- 10 fractional (3/16" to 9/16") and 11 metric (4 to 14mm) deep sockets
- 20 assorted 1/4" hex bits with bit holder
- 5 ratchet/socket accessories
- 1 quick release ratchet

Set Components (3/8" Drive):

- 13 fractional (1/4" to 1") and 19 metric (6 to 24mm) standard sockets
- 11 fractional (3/8" to 1") and 15 metric (10 to 24mm) deep sockets
- 11 external Torx® sockets (E4 to E20)
- 2 spark plug sockets (5/8", 13/16")
- 3 metric hex socket drivers (7, 8, 10mm)
- 4 tamper resistant Torx® socket drivers (T40, T45, T50, T55)
- 6 ratchet/socket accessories
- 1 quick release ratchet
- 1 spinner handle
- Storage case included

1/4" & 1/2" Drive Socket & Tool Set, 78pcs

Order NO.: 201003

BLPGSSCM78



Set Components (1/4" Drive):

- 12 sockets (4, 4.5, 5, 5.5, 6, 7, 8, 9, 10, 11, 12, 13mm)
- 4 accessories (quick release ratchet, spinner handle, 4" extension bar and 1/4"F*1/4"H coupler)

Set Components (1/2" Drive):

- 21 sockets (8, 9, 10, 11, 12, 13, 14, 15, 16, 17, 18, 19, 20, 21, 22, 23, 24, 27, 30, 32, 34mm)
- 7 accessories (quick release ratchet, 16mm & 21mm spark plug socket, 3", 6" & 10" extension bar, 3/8" F*1/2" M 3 way adapter)

Set Components:

- 20 bits: hex bit (3, 4, 5, 6mm), Phillips® bits (#0, #1, #2, #3), square bit (S1 & S2), flat bit (4, 5, 5.5mm), Torx® bits (T8, T10, T15, T20, T25, T27, T30)
- 10 combination wrenches (10, 11, 12, 13, 14, 15, 16, 17, 18, 19mm)
- 3 pliers (side cutter (7"), long nose pliers (6"), slip joint pliers (10"))
- 1 adjustable wrench (8")
- Storage case included

1/4" & 3/8" Drive Socket & Wrench Set, 100pcs

Order NO.: 201002

BLPGSSC100



Set Components (1/4" Drive):

- 10 fractional (3/16" to 9/16") and 13 metric (4 to 14mm) standard sockets
- 5 ratchet/socket accessories
- 1 ratchet

Set Components (3/8" Drive):

- 13 fractional (1/4" to 1") and 19 metric (6 to 24mm) standard sockets
- 11 external Torx® sockets (E4 to E20)
- 2 spark plug sockets (5/8", 13/16")
- 5 ratchet/socket accessories
- 1 ratchet
- 1 spinner handle

Set Components (Combination Wrenches):

- 9 fractional combination wrenches (1/4" to 3/4")
- 10 metric combination wrenches (10 to 19mm)
- Storage case included

1/4", 3/8" & 1/2" Drive Torx® Bit Socket Set, 43pcs

Order NO.: 201004

BLPTSSC43



Set Components (1/4" drive):

- 5 external Torx® sockets (E4 to E8)
- 10 tamper resistant Torx® socket drivers (T6 to T10, T15, T20, T25, T27, T30)
- 10 tamper resistant long Torx® socket drivers (T6 to T10, T15, T20, T25, T27, T30)

Set Components (3/8" drive):

- 4 external Torx® sockets (E10, E12, E14, E16)
- 3 tamper resistant Torx® socket drivers (T40, T45, T50)
- 3 tamper resistant long Torx® socket drivers (T40, T45, T50)

Set Components (1/2" drive):

- 4 external Torx® sockets (E18, E20, E22, E34)
- 2 tamper resistant Torx® socket drivers (T55, T60)
- 2 tamper resistant long Torx® socket drivers (T55, T60)
- Storage case included

1/4" & 1/2" Drive Socket & Tool Set



1/4" Drive Stubby Bit Socket Set, 40pcs

Order NO.: 201005

BLPBSS40



Set Components:

- 10 metric hex drivers (2, 2.5, 3, 4, 5, 6, 7, 8, 9, 10mm)
- 10 fractional hex drivers (5/64", 3/32", 7/64", 1/8", 5/32", 3/16", 7/32", 1/4", 5/16", 3/8")
- 10 Torx® tamper proof drivers (TP8, TP10, TP15, TP20, TP25, TP27, TP30, TP40, TP45, TP50)
- 6 XZN triple square drivers (XZN4, XZN5, XZN6, XZN8, XZN10, XZN12)
- 2 Phillips® drivers (#1, #2)
- 2 flat tip drivers (1/4", 3/8")
- Storage case included

1/4" Drive Socket Set, 62pcs

Order NO.: 201006

BLPGSS1462



Set Components:

- 11 fractional (3/16" to 5/8") and 11 metric (4mm to 14mm) standard sockets
- 11 fractional (3/16" to 5/8") and 11 metric (4mm to 14mm) deep sockets
- 1 bit holder
- 4 hex bits (9/64", 3/16", 7/32", 1/4")
- 3 flat tip bits (5/32", 3/16", 1/4")
- 2 Phillips® bits (#1, #2)
- 7 ratchet/socket accessories
- 1 ratchet
- Storage case included

1/4" Drive Socket Set, 51pcs

Order NO.: 201007

BLPGSS1451A



Set Components:

- 10 fractional (3/16" to 9/16") and 13 metric (4 to 14mm) standard sockets
- 3 fractional (1/4", 5/16", 3/8") 8 pt. sockets
- 6 Torx® socket drivers (T8 to T27)
- 6 fractional hex socket drivers (1/8" to 5/16")
- 3 flat tip socket drivers (5/32", 7/32", 9/32")
- 3 Phillips® socket drivers (#0, #1, #2)
- 6 ratchet/socket accessories
- 1 ratchet
- Storage case included

1/4" Drive SAE Socket Set, 22pcs

Order NO.: 201008

BLPGSS1422



Set Components:

- 11 6 pt. sockets (3/16", 7/32", 1/4", 9/32", 5/16", 11/32", 3/8", 7/16", 1/2", 9/16", 5/8")
- 11 6 pt. deep sockets (3/16", 7/32", 1/4", 9/32", 5/16", 11/32", 3/8", 7/16", 1/2", 9/16", 5/8")
- Storage case included

3/8" Drive Socket Set, 85pcs

Order NO.: 201009

BLPGSS3885



Set Components:

- 13 fractional (1/4" to 1") and 14 metric (6 to 19mm) standard sockets
- 13 fractional (1/4" to 1") and 14 metric (6 to 19mm) deep sockets
- 11 external Torx® sockets (E4 to E20)
- 1 Phillips® socket driver (#3)
- 2 Pozidriv® socket drivers (#3 and #4)
- 8 tamper resistant Torx® socket drivers (T10 to T45)
- 2 spark plug sockets (5/8", 13/16")
- 4 ratchet/socket accessories
- 1 ratchet
- 1 breaker bar
- 1 spinner handle
- Storage case included

1/4" Drive SAE Socket Set, 22pcs

Order NO.: 201010

BLPGSSCT71



Set Components:

- 9 fractional combination wrenches (1/4" to 3/4")
- 10 metric combination wrenches (10 to 19mm)
- 12 fractional (5/16" to 1") and 15 metric (10 to 24mm) 6 pt. standard sockets
- 2 spark plug sockets (5/8", 13/16")
- 1 quick release ratchet
- 1 spinner handle
- 3 extensions (3", 6", 10")
- 1 bit holder (3/8" drive)
- 4 hex bits (1/8", 5/32", 7/32", 1/4")
- 3 flat tip bits (5/32", 3/16", 1/4")
- 4 Phillips® tip bits (#0, #1, #2, #3)
- 2 square tip bits (#1, #2)
- 1 diagonal cutting pliers (7")
- 1 long nose pliers (6")
- 1 groove joint pliers (10")
- 1 adjustable wrench (8")
- Storage case included

3/8" Drive Socket Set, 49pcs

Order NO.: 201011

BLPGSS3849



Set Components:

- 8 fractional (5/16" to 3/4") and 14 metric (6 to 19mm) standard 6 pt. sockets
- 8 fractional (5/16" to 3/4") and 13 metric (7 to 19mm) deep 12 pt. sockets
- 2 extensions (3", 6")
- 1 universal joint
- 1 3/8" female to 1/4" male Adaptor
- 1 ratchet
- Storage case included

Pass Thru Socket Set, 22pcs

Order NO.: 201013

BLPPTSS3822



Set Components:

- BLPPTS38 thru BLPPTS34 (3/8" to 3/4") sockets
- BLPPTSM8 thru BLPPTSM19 (8 to 19mm) metric sockets
- BLPPTA3438 pass thru adaptor
- BLPPTXT3 extension and BPRFPT10 ratchet
- Storage case included

3/8" Drive Socket & Wrench Set, 37pcs

Order NO.: 201012

BLPGSS3837



Set Components:

- 8 fractional (5/16" to 3/4") and 14 metric (6 to 19mm) standard 6 pt. sockets
- 4 fractional (5/16"-3/8", 7/16"-1/2", 9/16"-5/8", 11/16"-3/4") and 5 metric (10-11mm, 12-13mm, 14-15mm, 16-17mm, 18-19mm) double open end wrenches
- 2 extensions (3", 6")
- 1 ratchet
- 1 universal joint
- 2 adaptors: 1/4" female x 3/8" male, 3/8" female x 1/4" male
- Storage case included

1/2" Drive Socket Set, 33pcs

Order NO.: 201014

BLPGSS1233



Set Components:

- 15 fractional (3/8" to 1 1/4") and 12 metric (12 to 24mm) standard sockets
- 1 breaker bar
- 1 universal joint
- 1 quick release ratchet
- 3 extensions (3", 6", 10")
- Storage case included

1/4" & 3/8" & 1/2" Drive Socket & Wrench Set, 100 pcs

Order NO.: 202001

BLPATSCM100



Set Components (1/4" drive):

- 10 sockets (4, 5, 6, 7, 8, 9, 10, 11, 12, 13mm)
- 10 deep sockets (4, 5, 6, 7, 8, 9, 10, 11, 12, 13mm)
- 6 accessories (quick release ratchet handle, spinner handle, 1 1/2" & 3" extension bar, universal joint, 6" flexible handle)
- 6 hex bit sockets (3, 4, 5, 6, 7, 8mm)
- 7 flat & Phillips® bit sockets (4, 5.5, 6.5mm, #0, #1, #2, #3)
- 4 PZ bit sockets (#0, #1, #2, #3)
- 7 tamper Torx® bit sockets (TT10, TT15, TT20, TT25, TT27, TT30, TT40)

Set Components (3/8" drive):

- 10 6 pt. sockets (10, 11, 12, 13, 14, 15, 16, 17, 18, 19mm)
- 10 deep 12 pt. sockets (10, 11, 12, 13, 14, 15, 16, 17, 18, 19mm)
- 10 accessories (quick release ratchet, 3", 6" & 10" extension bar, 16mm & 21mm spark plug socket, universal joint, 10" flexible handle, 3/8" female x 1/4" male adaptor, 8" sliding T-handle)

Set Components (1/2" drive):

- 6 12 pt. sockets (20, 21, 22, 24, 27, 32mm)
- 8 6 pt. impact sockets (14, 15, 16, 17, 18, 19, 21, 22mm)
- 2 accessories (ratchet handle, 5" extension bar)

Set Components:

- 4 ratcheting wrenches (13, 14, 15, 17mm)
- Storage case included

3/8" Drive Socket Set, 77pcs

Order NO.: 202005

BLPATSM3877



Set Components:

- 19 6 pt. sockets (6, 7, 8, 9, 10, 11, 12, 13, 14, 15, 16, 17, 18, 19, 20, 21, 22, 23, 24mm)
- 19 12 pt. deep sockets (6, 7, 8, 9, 10, 11, 12, 13, 14, 15, 16, 17, 18, 19, 20, 21, 22, 23, 24mm)
- 11 external Torx® sockets (E4, E5, E6, E7, E8, E10, E12, E14, E16, E18, E20)
- 4 hex bit sockets (6, 7, 8, 10mm)
- 2 Phillips® bit sockets (#3, #4)
- 2 PZ bit sockets (#3, #4)
- 8 tamper Torx® bit sockets (TT10, TT15, TT20, TT25, TT27, TT30, TT40, TT45)
- 12 accessories (quick release ratchet, 3", 6" & 10" extension bar, 16 & 21mm spark plug sockets, universal joint, 10" flexible handle, 3/8" female x 1/2" male adaptor, 3/8" female x 1/4" male adaptor, spinner handle, 8" sliding T-handle)
- Storage case included

1/4" Dr. Socket Set, 29pcs

Order NO.: 202002

BLPATSM1429



Set Components:

- 13 6 pt. sockets (4, 4.5, 5, 5.5, 6, 7, 8, 9, 10, 11, 12, 13, 14mm)
- 11 6 pt. deep sockets (4, 5, 6, 7, 8, 9, 10, 11, 12, 13, 14mm)
- 5 accessories (quick release ratchet, spinner handle, 3" & 6" extension bar, universal joint)
- Storage case included

3/8" Drive Socket Set, 24pcs

Order NO.: 202004

BLPATSM3824



Set Components:

- 10 12 pt. sockets (10, 11, 12, 13, 14, 15, 16, 17, 18, 19mm)
- 10 12 pt. deep sockets (10, 11, 12, 13, 14, 15, 16, 17, 18, 19mm)
- 4 accessories (quick release ratchet, 3" extension bar, 16 & 21mm spark plug sockets)
- Storage case included

1/4" & 3/8" & 1/2" Socket Set, 128pcs

Order NO.: 202007

BLPATSCM128



New

Set Components (1/4" Drive):

- 10 6pt. metric (4 to 13mm) deep sockets
- 10 6pt. metric (4 to 13mm) standard sockets
- 24 socket driver: Flat (4, 5.5, 6.5mm), Hex (3, 4, 5, 6, 7, 8mm), Phillips® (#0, 1, 2, 3), Tamper Resistant Torx® (T10, 15, 20, 25, 27, 30, 40), Pozidriv® (#0, 1, 2, 3)
- 7 accessories (38mm & 75mm extension bar, universal joint, 6" flexible handle, 6" spinner handle, quick release ratchet handle, 1/4"F*1/4"H bit adaptor)
- 17 bits: Hex (1/8, 5/32, 3/16, 7/32, 1/4"), Flat (7/32, 3/16, 1/4", 9/32"), bit adaptor, Torx® (T8, T10, T15, T20, T25, T27, T30, T40)

Set Components (3/8" Drive):

- 10 12pt. metric (10 to 19mm) deep sockets
- 10 6pt. metric (10 to 19mm) standard sockets
- 10 accessories (3/8" female x 1/4" male adaptor, 75mm, 150mm & 250mm extension bar, 10" flexible handle, quick release ratchet handle, universal joint, 8" sliding bar, 6pt. 16mm & 21mm spark plug socket)

Set Components (1/2" Drive):

- 6 6pt. metric (20, 21, 22, 24, 27, 32mm) standard sockets
- 8 6pt. metric (14, 15, 16, 17, 18, 19, 21, 22mm) impact sockets
- 3 accessories (125mm extension bar, quick release ratchet handle, 1/4" female x 1/4" hex coupler)

Set Components:

- 4 ratcheting wrenches (13, 14, 15, 17mm)
- 9pcs hex key set (1.5, 2, 2.5, 3, 4, 5, 6, 8, 10mm)
- Storage case included

1/2" Drive Socket Set, 25pcs

Order NO.: 202003

BLPATSM1225



Set Components:

- 19 6 pt. sockets (10, 11, 12, 13, 14, 15, 16, 17, 18, 19, 20, 21, 22, 24, 27, 30, 32, 34, 36mm)
- 6 accessories (quick release ratchet, 5" & 10" extension bar, 3/8" female x 1/2" male 3 way adapter, 16 & 21mm spark plug socket)
- Storage case included

1/2" Drive Impact Socket Set, 15pcs

Order NO.: 202006

BLPATSIMM1215



Set Components:

- 14 6 pt. impact sockets (10, 11, 12, 13, 14, 15, 16, 17, 18, 19, 21, 22, 23, 24mm)
- 1 impact extension bar (5")
- Storage case included



Sockets, Ratchet & Accessories



Blue-Point sockets & ratchets are made combining high grade materials with the best manufacturing process available to ensure good performance and fit.

High Grade Materials

Sockets are made with high alloy content steel for a stronger, more durable tool.

Best Industrial Manufacturing Process

In making each socket, we employ the best manufacturing process available, adhering to exact treatment conditions and parameters to give it a good mixture of strength and durability.

Better Socket Design

Our sockets are thin-walled with appropriate broach depth to provide greater access into tight spots and fit better for more applications.

Patented Wrenching System

Flank Drive® is also incorporated into our socket design to achieve a higher torque while preventing rounding of fasteners.

High Efficiency

The ratcheting gear in Blue-Point ratchets feature high teeth count for working with a shorter swing arc. This allows jobs to be done in tight spots as well as enhancing work output with lesser swings needed.

We incorporate better design and concept wherever applicable to make a better performing tool. Blue-point sockets & ratchets are tools manufactured to the highest quality.

1/4"	18
3/8"	23
1/2"	28
3/4"	32

1/4" Socket



Stock No.	Size (mm)	Length (mm)	Packing	Order No.
BLPSM143.5	3.5	25	6	301001
BLPSM144	4	25	6	301002
BLPSM144.5	4.5	25	6	301003
BLPSM145	5	25	6	301004
BLPSM145.5	5.5	25	6	301005
BLPSM146	6	25	6	301006
BLPSM147	7	25	6	301007
BLPSM148	8	25	6	301008
BLPSM149	9	25	6	301009
BLPSM1410	10	25	6	301010
BLPSM1411	11	25	6	301011
BLPSM1412	12	25	6	301012
BLPSM1413	13	25	6	301013
BLPSM1414	14	25	6	301014

1/4" Long Socket



Stock No.	Size (mm)	Length (mm)	Packing	Order No.
BLPLSM144	4	50	6	301015
BLPLSM145	5	50	6	301016
BLPLSM146	6	50	6	301017
BLPLSM147	7	50	6	301018
BLPLSM148	8	50	6	301019
BLPLSM149	9	50	6	301020
BLPLSM1410	10	50	6	301021
BLPLSM1411	11	50	6	301022
BLPLSM1412	12	50	6	301023
BLPLSM1413	13	50	6	301024
BLPLSM1414	14	50	6	301025

1/4" Socket



Stock No.	Size (inches)	Length (mm)	Packing	Order No.
BLPS14532	5/32	25	6	301026
BLPS14316	3/16	25	6	301027
BLPS14732	7/32	25	6	301028
BLPS1414	1/4	25	6	301029
BLPS14932	9/32	25	6	301030
BLPS14516	5/16	25	6	301031
BLPS141132	11/32	25	6	301032
BLPS1438	3/8	25	6	301033
BLPS14716	7/16	25	6	301034
BLPS1412	1/2	25	6	301035
BLPS14916	9/16	25	6	301036
BLPS1458	5/8	25	6	301037

- Manufactured from high grade steel alloy
- Features a Lifetime Warranty and exceeds ANSI Standards

1/4" Long Socket

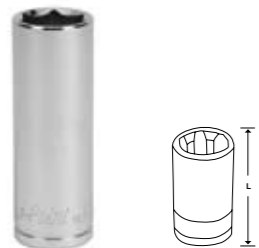

Stock No.	Size (inches)	Length (mm)	Packing	Order No.
BLPLS14316	3/16	50	6	301038
BLPLS14732	7/32	50	6	301039
BLPLS1414	1/4	50	6	301040
BLPLS14932	9/32	50	6	301041
BLPLS14516	5/16	50	6	301042
BLPLS141132	11/32	50	6	301043
BLPLS1438	3/8	50	6	301044
BLPLS14716	7/16	50	6	301045
BLPLS1412	1/2	50	6	301046
BLPLS14916	9/16	50	6	301047
BLPLS1458	5/8	50	6	301048

1/4" Double Square Socket



Stock No.	Size (inches)	Length (mm)	Packing	Order No.
BLPS81414	1/4	25	6	301049
BLPS814516	5/16	25	6	301050
BLPS81438	3/8	25	6	301051

1/4" External Torx® Socket



Stock No.	Size	Length (mm)	Packing	Order No.
BLPTE144	E4	25	6	301052
BLPTE145	E5	25	6	301053
BLPTE146	E6	25	6	301054
BLPTE147	E7	25	6	301055
BLPTE148	E8	25	6	301056

- Manufactured from high grade steel alloy
- Features a Lifetime Warranty and exceeds ANSI Standards

1/4" Quick Release Ratchet

Packing: 1 Order NO.: 301057

BPRTR936

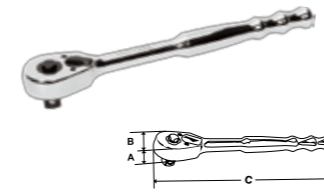

Square Drive (inches)	Description	Gear Teeth
1/4	Standard Handle	36
Swing Arc		
	A (mm)	B (mm)
10°	12	25
C (mm)		Repair Kit
143		RKRBPTR936

- Features quick release button for rapid socket/accessory changes, even with greasy or oily hands
- Contoured handle for comfort and control
- Chrome finish for easy clean-up
- All ratchets in series meet or exceed ANSI B107-10M-1996 specifications
- Uses RKRBPTR936 ratchet service kit

1/4" Quick Release Ratchet, Soft Grip

Packing: 1 Order NO.: 301058

BPRTR936SG

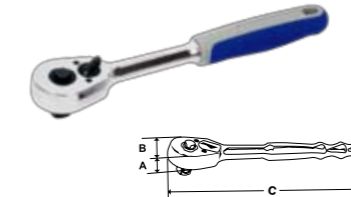

Square Drive (inches)	Description	Gear Teeth
1/4	Soft Grip Handle	36
Swing Arc		
	A (mm)	B (mm)
10°	12	25
C (mm)		Repair Kit
143		RKRBPTR936

- Features quick release button for rapid socket/accessory changes, even with greasy or oily hands
- Corrosive resistant bi-mold cushion grip for improved comfort and performance
- Chrome finish for easy clean-up
- All ratchets in series meet or exceed ANSI B107-10M-1996 specifications
- Uses RKRBPTR936 ratchet service kit

Finger Ratchet



Stock No.	Square Drive (inches)	Packing	Order No.
FSD14	3/8 male-1/4 female	1	301059
FSD38	1/4 male-3/8 female	1	301060
FSDR	1/4 male-1/4 female	1	301061

- Reversible, finger ratchet
- Small size works great for extremely tight areas
- Aluminum knurled outer ring for sure grip

1/4" Extension, Knurled



Stock No.	Length (mm)	Packing	Order No.
BLPTXK1.5	40	6	301062
BLPTXK2	51	6	301063
BLPTXK3	76	6	301064
BLPTXK4	102	6	301065
BLPTXK6	152	6	301066

- Manufactured from high grade steel alloy
- Features a Lifetime Warranty and exceeds ANSI Standards

1/4" Extension, Extra Long Locking

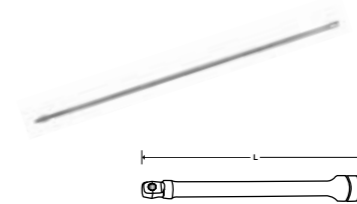

Stock No.	Length (mm)	Packing	Order No.
BLPEXTL1412	305	6	301067
BLPEXTL1418	457	6	301068
BLPEXTL1424	610	6	301069

- Smooth, durable chrome finish
- Made from tough 6130 steel
- Secure socket retention
- Lifetime warranty on individual extensions
- Do not use with power or impact tools

1/4" Flexible Extension

Packing: 6 Order NO.: 301070

BLPEXTF146

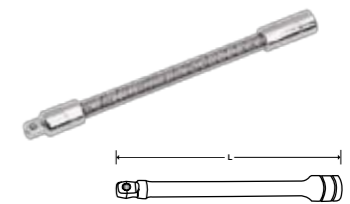

Stock No.	Length (mm)
BLPEXTF146	152

- Manufactured from high grade steel alloy
- Features a Lifetime Warranty and exceeds ANSI Standards

1/4" Breaker Bar

Packing: 6 Order NO.: 301071

BLPBB146

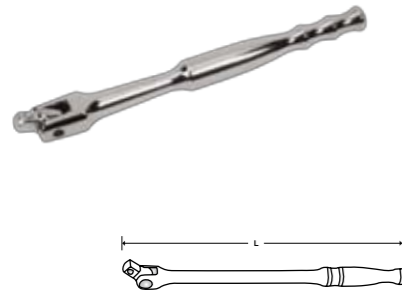

Stock No.	Length (mm)
BLPBB146	152

- Manufactured from high grade steel alloy
- Features a Lifetime Warranty and exceeds ANSI Standards

1/4" Sliding T-handle, 4"

Packing: 6 Order NO.: 301072

BLPSTHD144

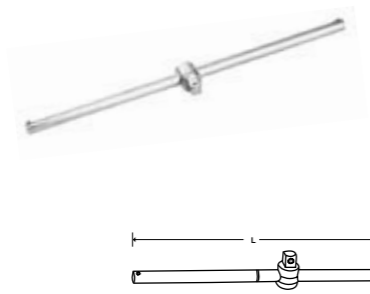

Stock No.	Length (mm)
BLPSTHD144	114

1/4" Spinner Handle

Packing: 6 Order NO.: 301073

BLPCGHD146



Stock No.	Length (mm)
BLPCGHD146	152

1/4" Universal Joint

Packing: 6 Order NO.: 301074

BLPUJ14



Stock No.	Length (mm)
BLPUJ14	38

- Manufactured from high grade steel alloy
- Features a Lifetime Warranty and exceeds ANSI Standards

1/4" Adaptor

Packing: 6 Order NO.: 301075

BLPAFM1438



Stock No.	Internal Square Drive (inches)	External Square Drive (inches)
BLPAFM1438	1/4	3/8

1/4" Bit Holder

Packing: 6 Order NO.: 301076

BLPTMBS1414



Stock No.	Length (mm)	Description
BLPTMBS1414	27	for 1/4" Hex Bits

1/4" Torx® Socket Driver



Stock No.	Size	Length (mm)	Packing	Order No.
BLPTS0148	T8	19	6	301077
BLPTS01410	T10	19	6	301078
BLPTS01415	T15	19	6	301079
BLPTS01420	T20	19	6	301080
BLPTS01425	T25	19	6	301081
BLPTS01427	T27	19	6	301082
BLPTS01430	T30	19	6	301083
BLPTS01440	T40	19	6	301084
BLPTS01445	T45	19	6	301085
BLPTS01447	T47	19	6	301086
BLPTS01450	T50	19	6	301087

- The BLPTS Series of Stubby Torx® socket drivers feature a reduced fastener depth penetration to increase strength and improve fastener engagement
- Manufactured from S2 Steel for longer tool life

1/4" Hex Socket Driver



Stock No.	Size (mm)	Length (mm)	Packing	Order No.
BLPHSM0142	2	19	6	301088
BLPHSM01425	2.5	19	6	301089
BLPHSM0143	3	19	6	301090
BLPHSM0144	4	19	6	301091
BLPHSM0145	5	19	6	301092
BLPHSM0146	6	19	6	301093
BLPHSM0147	7	19	6	301094
BLPHSM0148	8	19	6	301095
BLPHSM0149	9	19	6	301096
BLPHSM01410	10	19	6	301097

- The BLPHSM Series of Stubby Hex socket drivers feature a reduced fastener depth penetration to increase strength and improve fastener engagement
- Manufactured from S2 Steel for longer tool life

1/4" Hex Socket Driver, Tamper Resistant



Stock No.	Size (mm)	Length (mm)	Packing	Order No.
BLPTHSM0142	2	19	6	301098
BLPTHSM01425	2.5	19	6	301099
BLPTHSM0143	3	19	6	301100
BLPTHSM0144	4	19	6	301101
BLPTHSM0145	5	19	6	301102
BLPTHSM0146	6	19	6	301103
BLPTHSM0147	7	19	6	301104
BLPTHSM0148	8	19	6	301105
BLPTHSM0149	9	19	6	301106
BLPTHSM01410	10	19	6	301107

- The BLPTHSM Series of Stubby Hex Tamper Resistant socket drivers feature a reduced fastener depth penetration to increase strength and improve fastener engagement
- Manufactured from S2 Steel for longer tool life

1/4" Phillips® Socket Driver



Stock No.	Size	Length (mm)	Packing	Order No.
BLPP140	#0	37	6	301108
BLPP141	#1	37	6	301109
BLPP142	#2	37	6	301110
BLPP143	#3	37	6	301111
BLPP144	#4	37	6	301112

- Manufactured from high grade steel alloy
- Features a Lifetime Warranty and exceeds ANSI Standards

1/4" Phillips® Socket Driver, Stubby



Stock No.	Size	Length (mm)	Packing	Order No.
BLPPS141	#1	19	6	301113
BLPPS142	#2	19	6	301114

- Stubby Phillips® socket drivers feature a reduced fastener depth penetration to increase strength and improve fastener engagement
- Manufactured from S2 Steel for longer tool life

1/4" Pozidriv® Socket Driver



Stock No.	Size	Length (mm)	Packing	Order No.
BLPPD141	#1	37	6	301115
BLPPD142	#2	37	6	301116
BLPPD143	#3	37	6	301117

- Manufactured from high grade steel alloy
- Features a Lifetime Warranty and exceeds ANSI Standards

1/4" Triple Square Socket Driver



Stock No.	Size (mm)	Length (mm)	Order No.
BLPXZN144	4	27	301132
BLPXZN145	5	27	301133
BLPXZN146	6	27	301134
BLPXZN148	8	27	301135
BLPXZN1410	10	27	301136
BLPXZN1412	12	27	301137

1/4" Torx, Tamper Resistant



Stock No.	Square Drive (inches)	A	#	Order No.
BLPT146TP	1/4	1 7/16	T6	301138
BLPT147TP	1/4	1 7/16	T7	301139
BLPT148TP	1/4	1 7/16	T8	301140
BLPT149TP	1/4	1 7/16	T9	301141
BLPT1410TP	1/4	1 7/16	T10	301142
BLPT1415TP	1/4	1 7/16	T15	301143
BLPT1420TP	1/4	1 7/16	T20	301144
BLPT1425TP	1/4	1 7/16	T25	301145
BLPT1427TP	1/4	1 7/16	T27	301146
BLPT1430TP	1/4	1 7/16	T30	301147

1/4" Flat Tip Socket Driver, Standard



Stock No.	Size (inches)	Size (mm)	Length (mm)	Order No.
BLPFT144	5/32	4	37	301118
BLPFT145.5	7/32	5.5	37	301119
BLPFT146.5	9/32	6.5	37	301120

1/4" Flat Tip Socket Driver, Short



Stock No.	Size (inches)	Length (mm)	Order No.
BLPFS01414	1/4	19	301121
BLPFS01438	3/8	19	301122

- Manufactured from high grade steel alloy
- Features a Lifetime Warranty and exceeds ANSI Standards

3/8" Socket



Flank-Drive features optimal contact point and angle

Optimal heat treatment & material composition for strength & durability

Thinner walls to reach better into smaller recesses

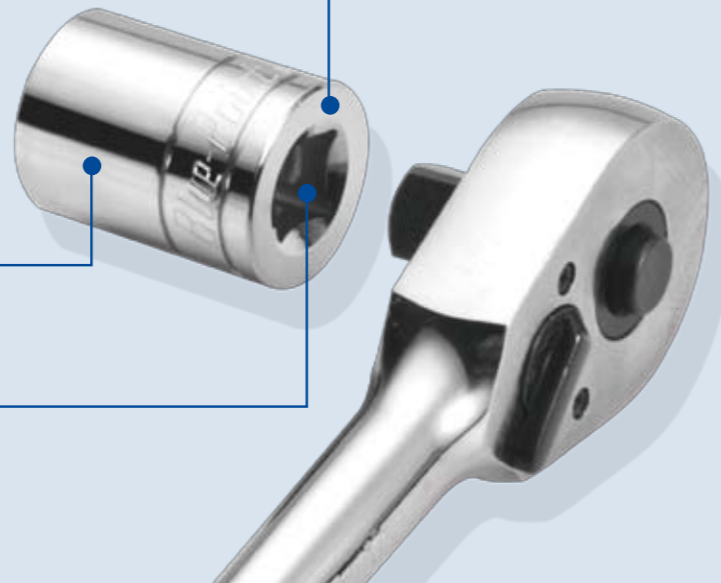

3/8" Socket



Stock No.	Size (mm)	Length (mm)	Order No.
BLPSM386	6	25.5	302001
BLPSM387	7	25.5	302002
BLPSM388	8	25.5	302003
BLPSM389	9	25.5	302004
BLPSM3810	10	25.5	302005
BLPSM3811	11	25.5	302006
BLPSM3812	12	25.5	302007
BLPSM3813	13	25.5	302008
BLPSM3814	14	27	302009
BLPSM3815	15	27	302010

3/8" Long Socket



Stock No.	Size (mm)	Length (mm)	Order No.
BLPLM386	6	64	302020
BLPLM387	7	64	302021
BLPLM388	8	64	302022
BLPLM389	9	64	302023
BLPLM3810	10	64	302024
BLPLM3811	11	64	302025
BLPLM3812	12	64	302026
BLPLM3813	13	64	302027
BLPLM3814	14	64	302028
BLPLM3815	15	64	302029

- Manufactured from high grade steel alloy
- Features a Lifetime Warranty and exceeds ANSI Standards

3/8" Socket



Stock No.	Size (inches)	Length (mm)	Order No.
BLPS3814	1/4	25	302039
BLPS38516	5/16	25	302040
BLPS3838	3/8	25	302041
BLPS38716	7/16	25	302042
BLPS3812	1/2	25	302043
BLPS38916	9/16	27	302044
BLPS3858	5/8	27	302045
BLPS381116	11/16	27	302046
BLPS3834	3/4	29	302047
BLPS381316	13/16	29	302048
BLPS3878	7/8	29	302049
BLPS381516	15/16	29	302050
BLPS381	1	29	302051

3/8" Long Socket



Stock No.	Size (inches)	Length (mm)	Order No.
BLPL3814	1/4	64	302052
BLPL38516	5/16	64	302053
BLPL3838	3/8	64	302054
BLPL38716	7/16	64	302055
BLPL3812	1/2	64	302056
BLPL38916	9/16	64	302057
BLPL3858	5/8	64	302058
BLPL381116	11/16	64	302059
BLPL3834	3/4	64	302060
BLPL381316	13/16	64	302061
BLPL3878	7/8	64	302062
BLPL381516	15/16	64	302063
BLPL381	1	64	302064

3/8" External Torx® Socket



Stock No.	Size	Length (mm)	Order No.
BLPTE384	E4	31	302065
BLPTE385	E5	31	302066
BLPTE386	E6	31	302067
BLPTE387	E7	31	302068
BLPTE388	E8	31	302069
BLPTE3810	E10	31	302070
BLPTE3811	E11	31	302071
BLPTE3812	E12	31	302072
BLPTE3814	E14	31	302073
BLPTE3816	E16	31	302074
BLPTE3818	E18	31	302075
BLPTE3820	E20	31	302076

- Manufactured from high grade steel alloy
- Features a Lifetime Warranty and exceeds ANSI Standards

3/8" Quick Release Ratchet

Packing: 1 Order NO.: 302081

BPRFR938

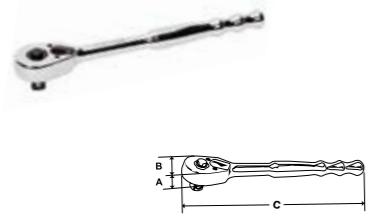

Square Drive (inches)	Description	Gear Teeth
3/8	Standard Handle	38
Swing Arc	A (mm)	B (mm)
9.5°	14	33
C (mm)	Repair Kit	
197	RKRBPRFR938	

- Features quick release button for rapid socket/accessory changes, even with greasy or oily hands
- Contoured handle for comfort and control
- Chrome finish for easy clean-up
- All ratchets in series meet or exceed ANSI B107-10M-1996 specifications

3/8" Quick Release Ratchet, Soft Grip

Packing: 1 Order NO.: 302082

BPRFR938SG

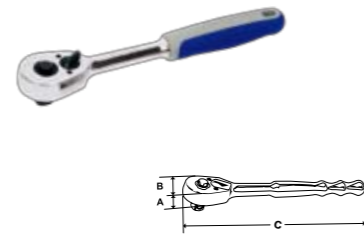

Square Drive (inches)	Description	Gear Teeth
3/8	Soft Grip Handle	38
Swing Arc	A (mm)	B (mm)
9.5°	14	33
C (mm)	Repair Kit	
197	RKRBPRFR938	

- Features quick release button for rapid socket/accessory changes, even with greasy or oily hands
- Corrosive resistant bi-mold cushion grip for improved comfort and performance
- Chrome finish for easy clean-up
- All ratchets in series meet or exceed ANSI B107-10M-1996 specifications

Finger Ratchet

FSD1



Stock No.	Square Drive (inches)	Packing	Order No.
FSDR1	3/8 male-1/4 female	1	302083
FSD1	3/8 male-3/8 female	1	302084

- Reversible, finger ratchet
- Small size works great for extremely tight areas
- Aluminum knurled outer ring for sure grip

3/8" Quick Release Ratchet

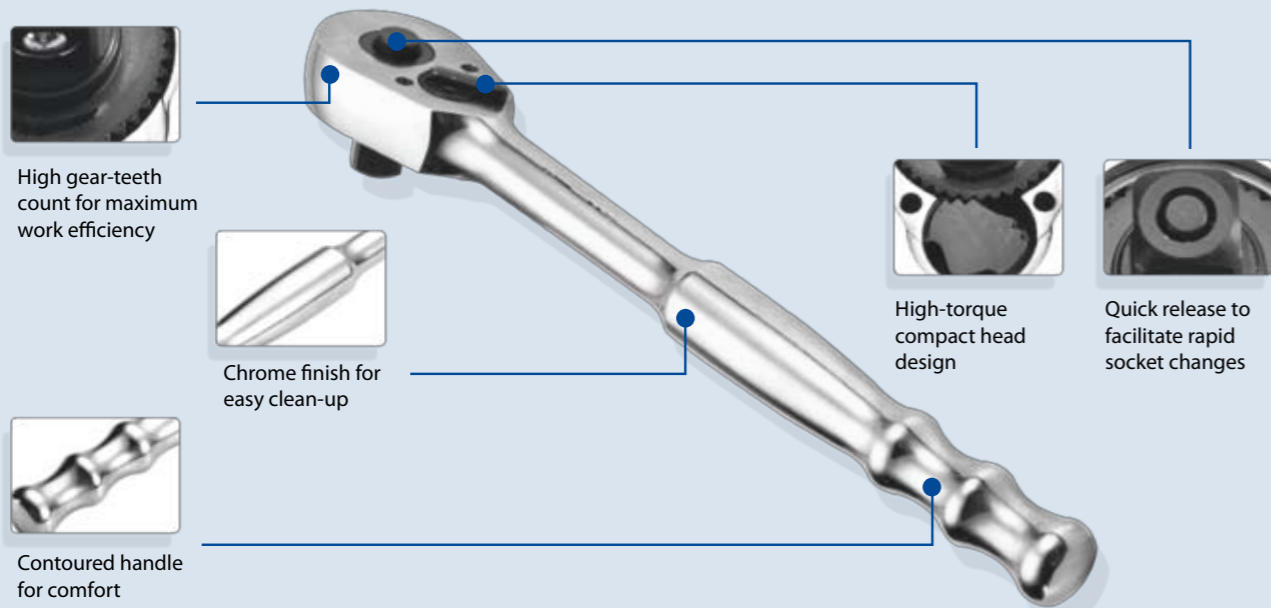

3/8" Universal Joint

Packing: 6 Order NO.: 302096

BLPUJ38



Stock No.	Length (mm)
BLPUJ38	52

- Manufactured from high grade steel alloy
- Features a Lifetime Warranty and exceeds ANSI Standards

3/8" Extension, Knurled

BLPEXTK3810



Stock No.	Length (mm)	Packing	Order No.
BLPEXTK383	75	6	302085
BLPEXTK386	150	6	302086
BLPEXTK3810	252	6	302087

- Manufactured from high grade steel alloy
- Features a Lifetime Warranty and exceeds ANSI Standards

3/8" Extension, Extra Long Locking

BLPEXTL3812

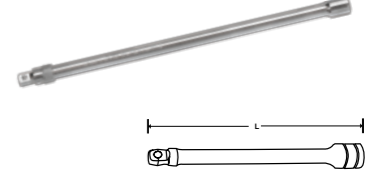

Stock No.	Length (mm)	Packing	Order No.
BLPEXTL3812	305	6	302091
BLPEXTL3818	457	6	302092
BLPEXTL3824	610	6	302093

3/8" Spark Plug Socket

BLPSPS3816



Stock No.	Size (mm)	Length (mm)	Packing	Order No.
BLPSPS3816	16	65	6	302077
BLPSPS3821	21	57	6	302078

3/8" Spark Plug Socket

BLPSPS3858



Stock No.	Size (inches)	Length (mm)	Packing	Order No.
BLPSPS3858	5/8	65	6	302079
BLPSPS381316	13/16	57	6	302080

3/8" Universal Joint

- Manufactured from high-grade alloy steel
- Offering same quality and features as our sockets with lifetime warranty

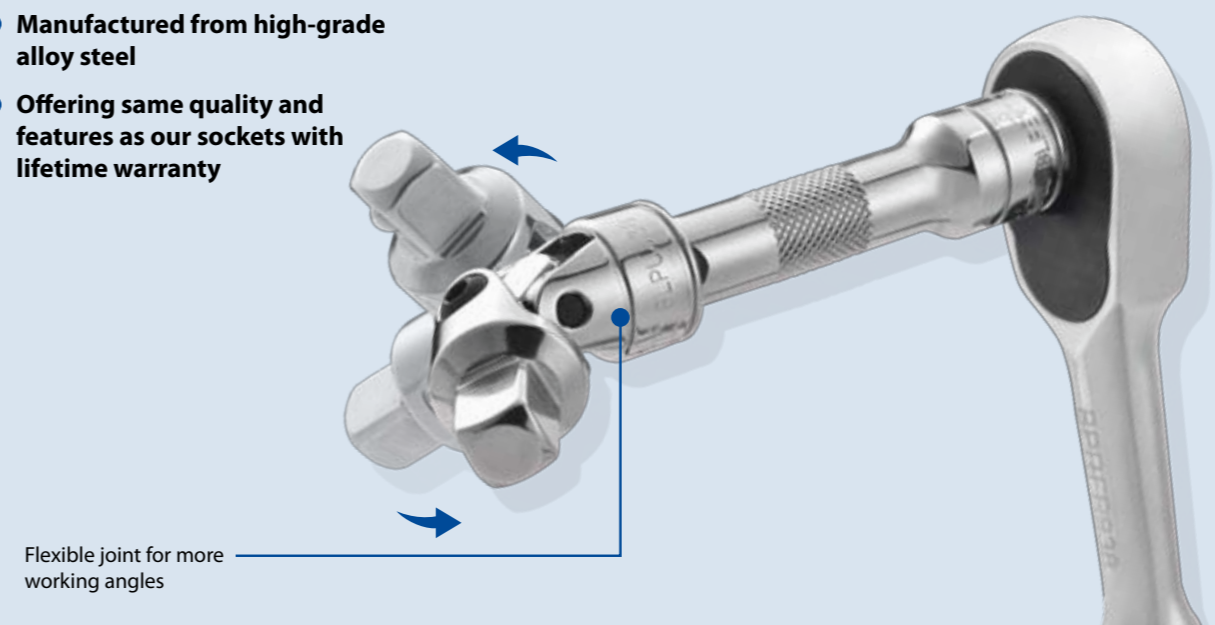

3/8" Sliding T-handle

Packing: 6 Order NO.: 302095

BLPSTHD388

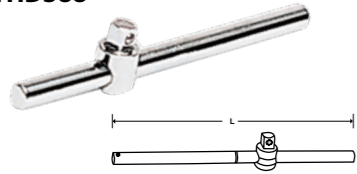

Stock No.	Length (mm)
BLPSTHD388	197

- Manufactured from high grade steel alloy
- Features a Lifetime Warranty and exceeds ANSI Standards

3/8" Adaptor



Stock No.	Internal Square Drive (inches)	External Square Drive (inches)	Packing	Order No.
BLPAFM3814	3/8	1/4	6	302097
BLPAFM3812	3/8	1/2	6	302098

3/8" Locking Extension

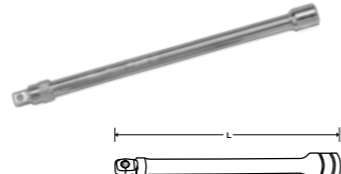

Stock No.	Length (mm)	Packing	Order No.
FXLBP3	76	6	302088
FXLBP6	152	6	302089
FXLBP10	254	6	302090

- Smooth, durable chrome finish
- Made from tough 6130 steel
- Secure socket retention
- Lifetime warranty on individual extensions
- Do not use with power or impact tools

Pass Thru Socket



Stock No.	Size (Inches)	Length (mm)	Packing	Order No.
BLPPTS38	3/8"	37	6	302101
BLPPTS716	7/16"	37	6	302102
BLPPTS12	1/2"	37	6	302103
BLPPTS916	9/16"	37	6	302104
BLPPTS58	5/8"	37	6	302105
BLPPTS1116	11/16"	37	6	302106
BLPPTS34	3/4"	37	6	302107

- Pass thru socket design avoids "bottoming out" on long fasteners and threaded rods
- Sockets can reach fasteners in tight spaces with relative ease

3/8" Torx® Socket Driver



Stock No.	Size	Length (mm)	Packing	Order No.	Stock No.	Size	Length (mm)	Packing	Order No.
BLPTS3810	T10	48	6	302123	BLPTS3840	T40	51	6	302129
BLPTS3815	T15	48	6	302124	BLPTS3845	T45	51	6	302130
BLPTS3820	T20	48	6	302125	BLPTS3850	T50	51	6	302131
BLPTS3825	T25	48	6	302126	BLPTS3855	T55	51	6	302132
BLPTS3827	T27	48	6	302127	BLPTS3860	T60	51	6	302133
BLPTS3830	T30	48	6	302128					

- Manufactured from high grade steel alloy
- Features a Lifetime Warranty and exceeds ANSI Standards

3/8" Breaker Bar

Packing: 6 Order NO.: 302094

BLPBB3810

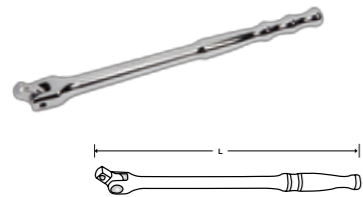

Stock No.	Length (mm)
BLPBB3810	253

3/8" Bit Holder

Packing: 6 Order NO.: 302099

BLPTMBS3814



Stock No.	Length (mm)	Description
BLPTMBS3814	19	For 1/4 Hex Bits

- Manufactured from high grade steel alloy
- Features a Lifetime Warranty and exceeds ANSI Standards

3/8" Torx, Tamper Resistant



Stock No.	Square Drive (inches)	A	#	Packing	Order No.
BLPT3810TP	3/8	1 27/32	T10	1	302166
BLPT3815TP	3/8	1 27/32	T15	1	302167
BLPT3820TP	3/8	1 27/32	T20	1	302168
BLPT3825TP	3/8	1 27/32	T25	1	302169
BLPT3827TP	3/8	1 27/32	T27	1	302170
BLPT3830TP	3/8	1 27/32	T30	1	302171
BLPT3840TP	3/8	2	T40	1	302172
BLPT3845TP	3/8	2	T45	1	302173
BLPT3850TP	3/8	2	T50	1	302174
BLPT3855TP	3/8	2	T55	1	302155

Pass Thru Socket



Stock No.	Size (mm)	Length (mm)	Packing	Order No.
BLPPTSM8	8	37	6	302108
BLPPTSM9	9	37	6	302109
BLPPTSM10	10	37	6	302110
BLPPTSM11	11	37	6	302111
BLPPTSM12	12	37	6	302112
BLPPTSM13	13	37	6	302113
BLPPTSM14	14	37	6	302114
BLPPTSM15	15	37	6	302115
BLPPTSM16	16	37	6	302116
BLPPTSM17	17	37	6	302117
BLPPTSM18	18	37	6	302118
BLPPTSM19	19	37	6	302119

- Pass thru socket design avoids "bottoming out" on long fasteners and threaded rods
- Sockets can reach fasteners in tight spaces with relative ease

3/8" Phillips® Socket Driver



Stock No.	Size	Length (mm)	Packing	Order No.
BLPP381	#1	47	6	302141
BLPP382	#2	47	6	302142
BLPP383	#3	47	6	302143
BLPP384	#4	47	6	302144

- Manufactured from high grade steel alloy
- Features a Lifetime Warranty and exceeds ANSI Standards

3/8" Pozidriv® Socket Driver



Stock No.	Size	Length (mm)	Packing	Order No.
BLPPD381	#1	47	6	302145
BLPPD382	#2	47	6	302146
BLPPD383	#3	47	6	302147
BLPPD384	#4	47	6	302148

3/8" Flat Socket Driver



Stock No.	Size (mm)	Length (mm)	Packing	Order No.
BLPFT3855	5.5	47	6	302149
BLPFT3865	6.5	47	6	302150
BLPFT388	8	47	6	302151

Pass Thru Ratchet

Packing: 6 Order NO.: 302120

BPRFPT10

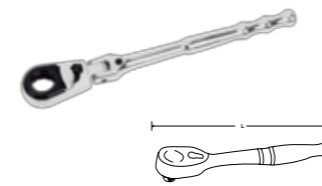

Stock No.	Length (mm)
BPRFPT10	254

- Ratchet features a flex head design that allows for seven different locking positions

Pass Thru Extension

Packing: 6 Order NO.: 302121

BLPPTEXT3

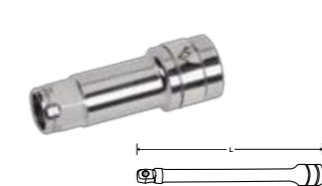

Stock No.	Length (mm)
BLPPTEXT3	76

- 3" extension
- 3/8" drive

3/8" Square Drive Pass Thru Adapter

Packing: 6 Order NO.: 302122

BLPPTA3438

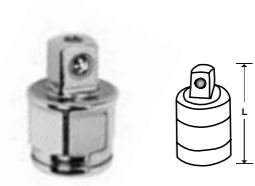

Stock No.	Length (mm)
BLPPTA3438	32

- Manufactured from high grade steel alloy
- Features a Lifetime Warranty and exceeds ANSI Standards

1/2" External Torx® Socket



Stock No.	Size	Length (mm)	Packing	Order No.
BLPTE1210	E10	38	6	303105
BLPTE1212	E12	38	6	303106
BLPTE1214	E14	38	6	303107
BLPTE1216	E16	38	6	303108
BLPTE1218	E18	38	6	303109
BLPTE1220	E20	38	6	303110
BLPTE1222	E22	38	6	303111
BLPTE1224	E24	38	6	303112

- Manufactured from high grade steel alloy
- Features a Lifetime Warranty and exceeds ANSI Standards

1/2" Quick Release Ratchet

Packing: 1

Order NO.: 303117

BPRSR940



Square Drive (inches)	Description	Gear Teeth
1/2	Standard Handle	40
Swing Arc	A (mm)	B (mm)
9°	18	44
C (mm)	Repair Kit	
251	RKRBPRSR940	

- Features quick release button for rapid socket/accessory changes, even with greasy or oily hands
- Contoured handle for comfort and control
- Chrome finish for easy clean-up
- All ratchets in series meet or exceed ANSI B107-10M-1996 specifications

1/2" Torx, Tamper Resistant



Stock No.	Square Drive (inches)	A	Hex	Order No.
BLPT1255TP	1/2	2 5/16	T55	303185
BLPT1260TP	1/2	2 5/16	T60	303186

- Manufactured from high grade steel alloy
- Features a Lifetime Warranty and exceeds ANSI Standards

1/2" Spark Plug Socket



Stock No.	Size (mm)	Length (mm)	Packing	Order No.
BLPSPS1216	16	65	6	303113
BLPSPS1221	21	57	6	303114

1/2" Spark Plug Socket



Stock No.	Size (inches)	Length (mm)	Packing	Order No.
BLPSPS1258	5/8	65	6	303115
BLPSPS121316	1 9/16	57	6	303116

1/2" Quick Release Ratchet, Soft Grip

Packing: 1

Order NO.: 303118

BPRSR940SG

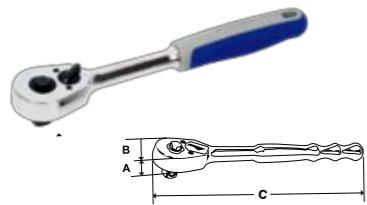

Square Drive (inches)	Description	Gear Teeth
1/2	Soft Grip Handle	40
Swing Arc	A (mm)	B (mm)
9°	18	44
C (mm)	Repair Kit	
103	RKRBPRSR940	

1/2" Extension Knurled

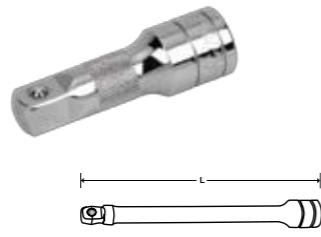

Stock No.	Length (mm)	Packing	Order No.
BLPEXTK123	76	6	303119
BLPEXTK125	127	6	303120
BLPEXTK126	152	6	303121
BLPEXTK1210	254	6	303122

1/2" Locking Extension

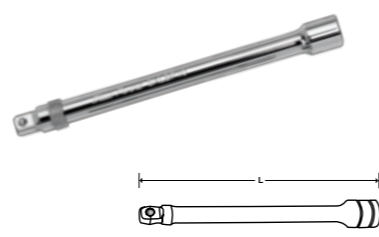

Stock No.	Length (mm)	Packing	Order No.
SXLBP3	76	6	303123
SXLBP6	152	6	303124
SXLBP10	254	6	303125

1/2" Sliding T-handle

Packing: 6

Order NO.: 303129

BLPSTHD1215

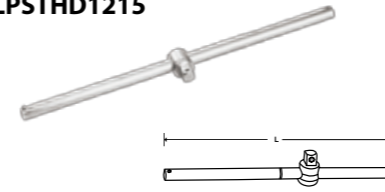

Stock No.	Length (mm)
BLPSTHD1215	381

- Manufactured from high grade steel alloy
- Features a Lifetime Warranty and exceeds ANSI Standards

1/2" Universal Joint

Packing: 6

Order NO.: 303130

BLPUJ12



Stock No.	Length (mm)
BLPUJ12	70

1/2" Speeder

Packing: 6

Order NO.: 303133

BLPS12

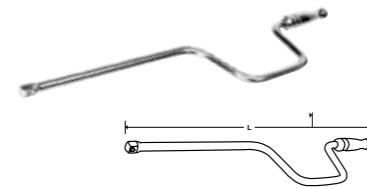

Stock No.	Internal Square Drive (inches)	External Square Drive (inches)	Length (mm)
BLPSH1238	1/2	3/8	457

BLPS12

- Manufactured from high grade steel alloy
- Features a Lifetime Warranty and exceeds ANSI Standards

1/2" Torx® Socket Driver



Stock No.	Size	Length (mm)	Packing	Order No.
BLPT1220	T20	37	6	303134
BLPT1225	T25	37	6	303135
BLPT1227	T27	37	6	303136
BLPT1230	T30	37	6	303137
BLPT1240	T40	37	6	303138
BLPT1245	T45	37	6	303139
BLPT1250	T50	37	6	303140
BLPT1255	T55	37	6	303141
BLPT1260	T60	37	6	303142

1/2" Breaker Bar

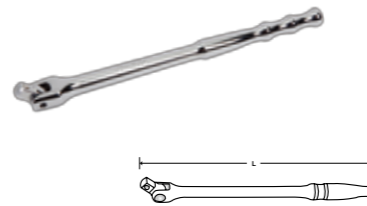

Stock No.	Length (mm)	Packing	Order No.
BLPBB1210	254	6	303126
BLPBB1215	381	6	303127
BLPBB1224	305-610	6	303128

- Manufactured from high grade steel alloy
- Features a Lifetime Warranty and exceeds ANSI Standards

1/2" Adaptor

Packing: 6

Order NO.: 303131

BLPAFM1238



Stock No.	Description	Length (mm)
BLPAFM1238	1/2 female - 3/8 male	37

1/2" Hex Socket Driver

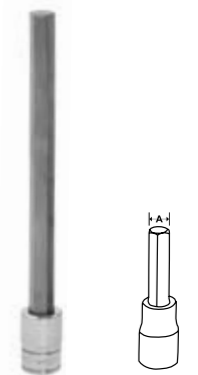

Stock No.	Size (mm)	Length (mm)	Packing	Order No.
BLPH123	3	36.5	6	303143
BLPH124	4	36.5	6	303144
BLPH125	5	36.5	6	303145
BLPH126	6	36.5	6	303146
BLPH127	7	36.5	6	303147
BLPH128	8	36.5	6	303148
BLPH1210	10	36.5	6	303149
BLPH1212	12	36.5	6	303150
BLPH1214	14	36.5	6	303151
BLPH1217	17	36.5	6	303152
BLPH1219	19	36.5	6	303153
BLPH125L180	5	180	6	303154
BLPH126L70	6	70	6	303155
BLPH126L140	6	140	6	303156
BLPH126L250	6	250	6	303157
BLPH128L120	8	120	6	303158
BLPH1210L140	10	140	6	303159

1/2" Triple Square Socket Driver



Stock No.	Size (inches)	Length (mm)	Packing	Order No.
BLPXZNM125	M5	37	6	303160
BLPXZNM126	M6	37	6	303161
BLPXZNM128	M8	37	6	303162
BLPXZNM1210	M10	37	6	303163
BLPXZNM1212	M12	37	6	303164
BLPXZNM1214	M14	37	6	303165
BLPXZNM1216	M16	37	6	303166

- Manufactured from high grade steel alloy
- Features a Lifetime Warranty and exceeds ANSI Standards

1/2" Long Torx® Socket Driver

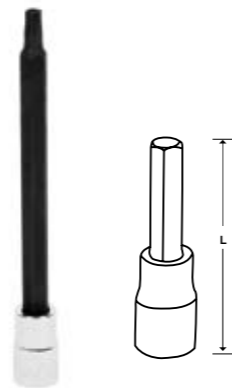

Stock No.	Size	Length (mm)	Packing	Order No.
BLPTL1220	T20	100	6	303167
BLPTL1225	T25	100	6	303168
BLPTL1227	T27	100	6	303169
BLPTL1230	T30	100	6	303170
BLPTL1240	T40	100	6	303171
BLPTL1245	T45	100	6	303172
BLPTL1250	T50	100	6	303173
BLPTL1255	T55	100	6	303174
BLPTL1260	T60	100	6	303175

1/2" Long Hex Socket Driver

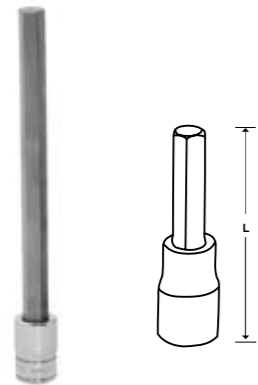

Stock No.	Size (mm)	Length (mm)	Packing	Order No.
BLPHL124	4	100	6	303176
BLPHL125	5	100	6	303177
BLPHL126	6	100	6	303178
BLPHL127	7	100	6	303179
BLPHL128	8	100	6	303180
BLPHL1210	10	100	6	303181
BLPHL1212	12	100	6	303182
BLPHL1214	14	100	6	303183
BLPHL1217	17	100	6	303184

- Manufactured from high grade steel alloy
- Features a Lifetime Warranty and exceeds ANSI Standards

3/4" Double Hex Socket



Stock No.	Size (mm)	Length (mm)	Packing	Order No.	Stock No.	Size (mm)	Length (mm)	Packing	Order No.
BLPDM3419	19	47	6	304001	BLPDM3432	32	58	6	304012
BLPDM3421	21	47	6	304002	BLPDM3433	33	60	6	304013
BLPDM3422	22	47	6	304003	BLPDM3434	34	60	6	304014
BLPDM3423	23	50	6	304004	BLPDM3435	35	60	6	304015
BLPDM3424	24	50	6	304005	BLPDM3436	36	63	6	304016
BLPDM3425	25	53	6	304006	BLPDM3438	38	63	6	304017
BLPDM3426	26	53	6	304007	BLPDM3440	40	66	6	304018
BLPDM3427	27	53	6	304008	BLPDM3446	46	68	6	304019
BLPDM3428	28	53	6	304009	BLPDM3450	50	68	6	304020
BLPDM3429	29	53	6	304010	BLPDM3455	55	69	6	304021
BLPDM3430	30	58	6	304011	BLPDM3460	60	72	6	304022

3/4" Quick Release Ratchet

Packing: 6 Order NO.: 304023

BPRSR942

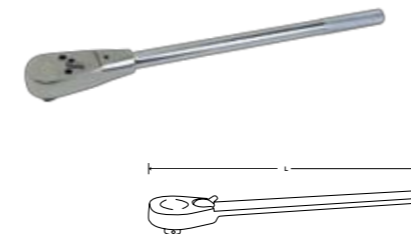

Stock No.	Square Drive (inches)	Length (mm)
BPRSR942	3/4	143

- Features quick release button for rapid socket/accessory changes, even with greasy or oily hands
- Contoured handle for comfort and control
- Chrome finish for easy clean-up
- All ratchets in series meet or exceed ANSI B107-10M-1996 specifications

3/4" Extension

Packing: 6 Order NO.: 304024

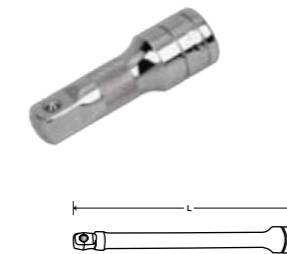

Stock No.	Length (mm)	Packing	Order No.
BLPEXT344	102	6	304024
BLPEXT348	203	6	304025
BLPEXT3416	406	6	304026

- Manufactured from high grade steel alloy
- Features a Lifetime Warranty and exceeds ANSI Standards

3/4" Universal Joint

Packing: 6 Order NO.: 304029

BLPUJ34



Stock No.	Length (mm)
BLPUJ34	110

3/4" Breaker Bar

Packing: 6 Order NO.: 304028

BLPBB3419

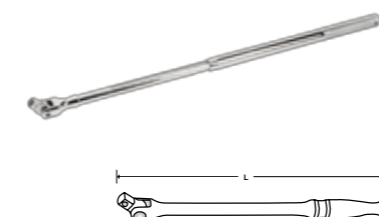

Stock No.	Length (mm)
BLPBB3419	483

- Manufactured from high grade steel alloy
- Features a Lifetime Warranty and exceeds ANSI Standards

3/4" Sliding T-handle

Packing: 6 Order NO.: 304027

BLPSTHD3418

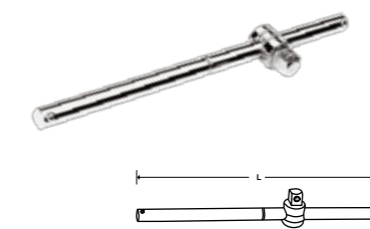

Stock No.	Length (mm)
BLPSTHD3418	457

3/4" L-Shape Wrench

Packing: 6 Order NO.: 304030

BLPLW3415

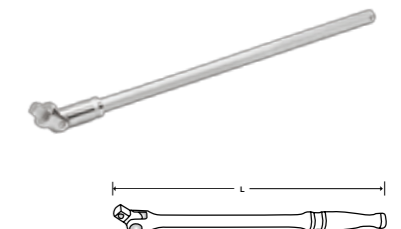

Stock No.	Length (mm)
BLPLW3415	381



Wrenches



The first of Blue-Point wrenches were designed to be unbreakable at its head, unable to spread its jaws or bend its handle, and cannot injure them nor destroy their everlasting efficiency. While most of our wrenches have evolved and improved with time, these core philosophies to quality are observed till today in our design.

Our ratcheting wrench uses gears with higher number of teeth so that you need less swings to tighten and loosen a fastener. In short, you work less to get each job done.

We kept the thickness of the jaws to the minimal without losing its required strength. This allows our wrench to reach better into constricted openings for any tightening or loosening task.

Flexible head is also incorporated into some designs to accommodate awkward working angles.

The ends of our wrench are set in an optimal angle so that you can flip it to get the best working angle.

Nickel chrome exterior finishes the wrench for corrosion resistance and a durable tool.

Wrench Sets	36
Adjustable Wrenches	38
Combination Wrenches	39
Double Open End Wrenches	39
Offset Wrench	40
Ratcheting Wrenches	40
T and L Shape Wrenches	43
Other Wrenches	43

Adjustable Wrench Set, 4pcs

Packing: 4 Order NO.: 401001



- Includes GAJ6A (6"), GAJ8A (8"), GAJ10A (10") and GAJ12A (12") adjustable wrenches

Adjustable Wrench Set, 3pcs

Packing: 3 Order NO.: 401002



- Includes GAJ15A (15"), GAJ18A (18") and GAJ24A (24") adjustable wrenches

Adjustable Wrench Set, 3pcs

Packing: 1 Order NO.: 401003



- Includes BADJC6 (6"), BADJC8 (8") and BADJC10 (10") composite handle adjustable wrenches

Adjustable Wrench Set, 4pcs

Packing: 4 Order NO.: 401004



- Includes GAJ6SG (6"), GAJ8SG (8"), GAJ10SG (10") and GAJ12SG (12") adjustable wrenches

Combination Wrench Set, 12pcs

Packing: 12 Order NO.: 401005



- Includes 8 to 19mm combination wrenches
- | | | |
|----------|----------|----------|
| BLPCWM8 | BLPCWM12 | BLPCWM16 |
| BLPCWM9 | BLPCWM13 | BLPCWM17 |
| BLPCWM10 | BLPCWM14 | BLPCWM18 |
| BLPCWM11 | BLPCWM15 | BLPCWM19 |

Combination Wrench Set, 11pcs

Packing: 1 Order NO.: 401006



- Includes 3/8" to 1" combination wrenches
- | | | |
|----------|-----------|-----------|
| BLPCW38 | BLPCW58 | BLPCW78 |
| BLPCW716 | BLPCW1116 | BLPCW1516 |
| BLPCW12 | BLPCW34 | BLPCW1 |
| BLPCW916 | BLPCW1316 | |

Ratcheting Wrench Set



- | Stock No. | Packing | Order No. |
|-----------|---------|-----------|
| BOER708 | 1 | 401009 |
| BOER704 | 1 | 401010 |
- BOER708**
 - Includes 5/16" to 3/4" ratchet combination wrenches

BOER10	BOER18
BOER12	BOER20
BOER14	BOER22
BOER16	BOER24
 - BOER704**
 - Includes BOER26, BOER28, BOER30 and BOER32 (13/16" to 1") ratchet combination wrenches

Ratcheting Wrench Set



- | Stock No. | Packing | Order No. |
|-----------|---------|-----------|
| BOERM712 | 1 | 401007 |
| BOERM704 | 1 | 401008 |
- BOERM712**
 - Includes 8 to 19mm ratchet combination wrenches

BOERM8	BOERM12	BOERM16
BOERM9	BOERM13	BOERM17
BOERM10	BOERM14	BOERM18
BOERM11	BOERM15	BOERM19
 - BOERM704**
 - Includes BOERM21, BOERM22, BOERM24 and BOERM25 (21 to 25mm) ratchet combination wrenches

Ratcheting Wrench Set, 12pcs

Packing: 1 Order NO.: 401015



- Includes 8 to 19mm short ratchet combination wrenches
- | | | |
|-----------|-----------|-----------|
| BOERMSF8 | BOERMSF12 | BOERMSF16 |
| BOERMSF9 | BOERMSF13 | BOERMSF17 |
| BOERMSF10 | BOERMSF14 | BOERMSF18 |
| BOERMSF11 | BOERMSF15 | BOERMSF19 |

Ratcheting Wrench Set, 12pcs

Packing: 1 Order NO.: 401011



- Includes 8 to 19mm flexible head ratchet combination wrenches
- | | | |
|-----------|-----------|-----------|
| BOERMF8A | BOERMF12A | BOERMF16A |
| BOERMF9A | BOERMF13A | BOERMF17A |
| BOERMF10A | BOERMF14A | BOERMF18A |
| BOERMF11A | BOERMF15A | BOERMF19A |

Ratcheting Wrench Set, 12pcs

Packing: 1 Order NO.: 401013



- Includes 8 to 19mm flexible head ratchet combination wrenches
- | | | |
|----------|----------|----------|
| BOERMS8 | BOERMS12 | BOERMS16 |
| BOERMS9 | BOERMS13 | BOERMS17 |
| BOERMS10 | BOERMS14 | BOERMS18 |
| BOERMS11 | BOERMS15 | BOERMS19 |

Ratcheting Wrench Set, 8pcs

Packing: 1 Order NO.: 401012



- Includes 5/16" to 3/4" flexible head ratchet combination wrenches
- | | |
|----------|----------|
| BOERF10A | BOERF18A |
| BOERF12A | BOERF20A |
| BOERF14A | BOERF22A |
| BOERF16A | BOERF24A |

Ratcheting Wrench Set, 8pcs

Packing: 1 Order NO.: 401014



- Includes 5/16" to 3/4" flexible head ratchet combination wrenches
- | | |
|---------|---------|
| BOERS10 | BOERS18 |
| BOERS12 | BOERS20 |
| BOERS14 | BOERS22 |
| BOERS16 | BOERS24 |

Ratcheting Wrench Set, 8pcs

Packing: 1 Order NO.: 401016



- Includes 5/16" to 3/4" short ratchet combination wrenches
- | | |
|----------|----------|
| BOERSF10 | BOERSF18 |
| BOERSF12 | BOERSF20 |
| BOERSF14 | BOERSF22 |
| BOERSF16 | BOERSF24 |

Ratcheting Wrench Set, 12pcs

Packing: 1 Order NO.: 401017



- Includes 8 to 19mm locking flexible head ratchet combination wrenches
- | | | |
|-------------|-------------|-------------|
| BOERMFLCG8 | BOERMFLCG12 | BOERMFLCG16 |
| BOERMFLCG9 | BOERMFLCG13 | BOERMFLCG17 |
| BOERMFLCG10 | BOERMFLCG14 | BOERMFLCG18 |
| BOERMFLCG11 | BOERMFLCG15 | BOERMFLCG19 |

Flexible Head Ratchet Combination Wrench

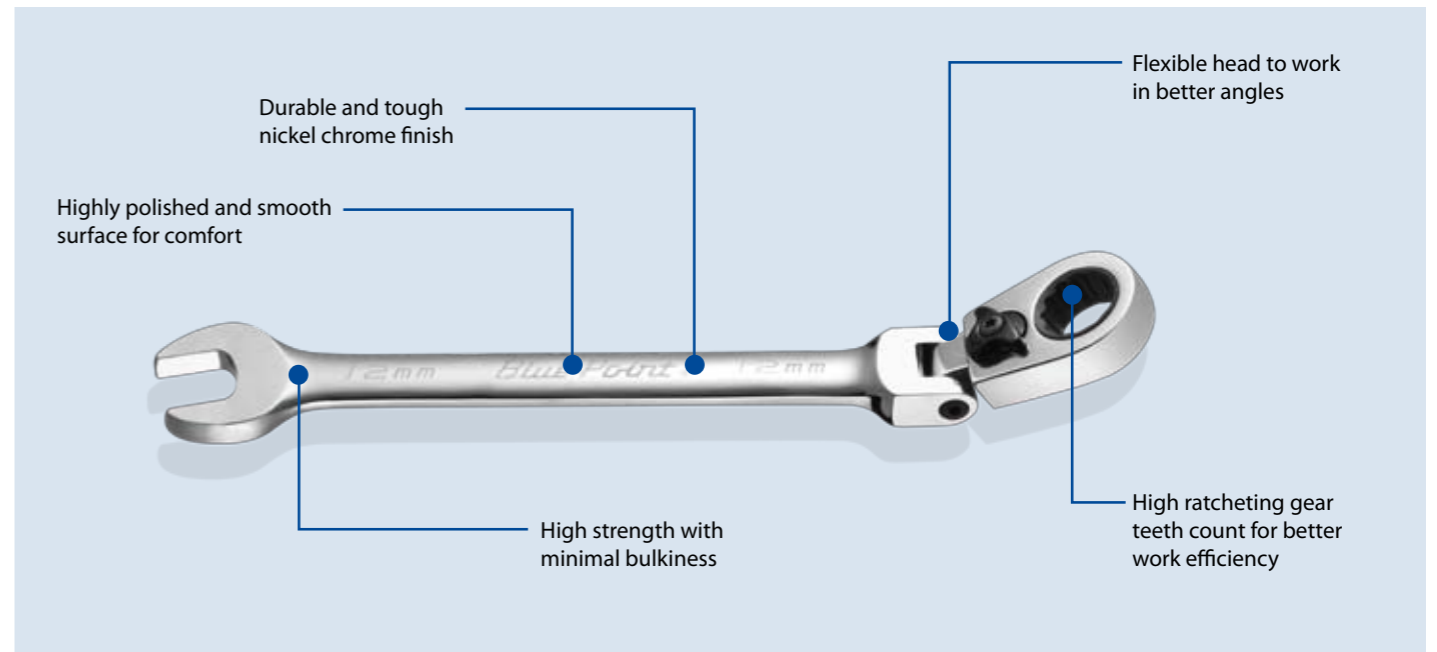

Ratcheting Box



Stock No.	mm	A (mm)	L (mm)	Order No.
RBZM78	7-8	15.1-17.1	114	406112
RBZM910	9-10	20.4-22.6	140	406113
RBZM1112	11-12	25.8-29.4	175	406114
RBZM1314	13-14	25.8-29.4	175	406115
RBZM1517	15-17	32.9-36.5	206	406116
RBZM1618	16-18	32.9-36.5	206	406117
RBZM1921	19-21	35.7-40.1	235	406118

Ratcheting Box



Stock No.	mm	A (inches)	L (inches)	Order No.
RBZ810	1/4-5/16	3/8	4 1/2	406119
RBZ1214	3/8-7/16	3/8	5 1/2	406120
RBZ1618	1/2-9/16	1/2	6 1/8	406121
RBZ2022	5/8-11/16	1/2	9 1/4	406122
RBZ2428	3/4-7/8	1/2	9 1/4	406123

Locking Flex Head Ratchet

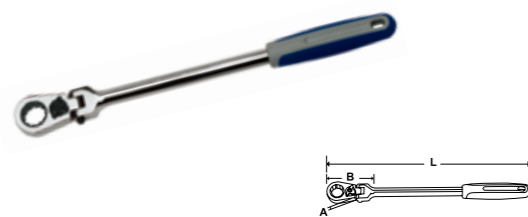

Stock No.	mm	A (mm)	B (mm)	L (mm)	Order No.
BOERMFLCG8	8	6.55	32	228	406092
BOERMFLCG9	9	7.45	34	229	406093
BOERMFLCG10	10	8.05	38	233	406094
BOERMFLCG11	11	8.55	40	235	406095
BOERMFLCG12	12	9.05	42	285	406096
BOERMFLCG13	13	10.05	45	287	406097
BOERMFLCG14	14	10.05	48	289	406098
BOERMFLCG15	15	11.05	52	293	406099
BOERMFLCG16	16	11.05	54	347	406100
BOERMFLCG17	17	12.05	56	348	406101
BOERMFLCG18	18	12.05	60	352	406102
BOERMFLCG19	19	12.95	64	354	406103

Locking Flex Head Ratchet

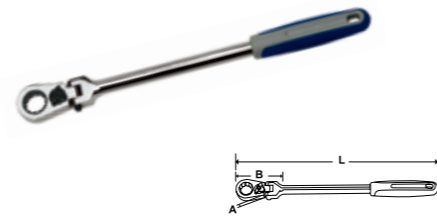

Stock No.	mm	A (inches)	B (inches)	L (inches)	Order No.
BOERFLCG10	5/16	1/4	1 1/4	9	406104
BOERFLCG12	3/8	5/16	1 1/2	8 1/4	406105
BOERFLCG14	7/16	11/32	1 9/16	9 19/32	406106
BOERFLCG16	1/2	13/32	1 25/32	11 9/32	406107
BOERFLCG18	9/16	13/32	1 29/32	11 3/8	406108
BOERFLCG20	5/8	7/16	2 1/8	13 21/32	406109
BOERFLCG22	11/16	15/32	2 7/32	13 23/32	406110
BOERFLCG24	3/4	1/2	2 17/32	13 15/16	406111

- Corrosive resistant bi-mold cushion grips for improved comfort and performance
- Wrenches have multiple locking head positions for easier access to tough to reach fasteners
- Long reach solid shank steel handle for improved reach and leverage
- Dual pawl reversible ratchet head
- Flex head pivots 90 degrees in either direction

L-Shape Hex Keys



Stock No.	mm	A (mm)	L (mm)	Order No.
BLWM12	12	44	209	407002
BLWM14	14	54.5	233	407003
BLWM17	17	61.5	276	407004
BLWM19	19	68.5	276	407005

- Made from high torque steel
- Heavy duty usage
- Satin finish

T-Shape Hex Keys



Stock No.	mm	A (mm)	L (mm)	Order No.
BTWM1.5	1.5	83	122	407007
BTWM2.5	2.5	83	122	407008
BTWM3	3	83	122	407009
BTWM4	4	83	122	407010
BTWM5	5	83	122	407011
BTWM6	6	134	186	407012
BTWM7	7	134	186	407013
BTWM8	8	134	186	407014

- Ergonomical handle for a better grip
- Made from high torque steel

T-Shape Speeder Wrench

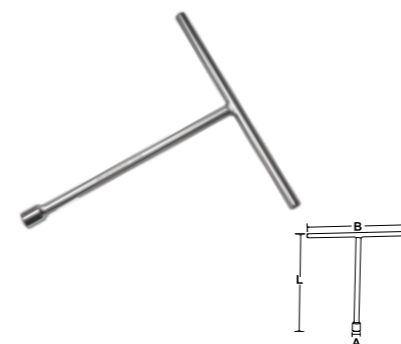

Stock No.	A (mm)	B (mm)	L (mm)	Order No.
BPTHM08	8	200	250	407015
BPTHM09	9	200	250	407016
BPTHM10	10	200	250	407017
BPTHM11	11	200	250	407018
BPTHM12	12	250	250	407019
BPTHM13	13	250	300	407020
BPTHM14	14	250	300	407021

- Speedy socket wrench, convenience for use
- Magnetic inset for convenience

Chain Wrench



Stock No.	Chain Length (inches)	Capacity (inches)	Handle Length (inches)	Order No.
CW12A	16	4	12	408001
CW15A	19	5	15	408002
CW24A	23	6	24	408003

Strap Wrench



Stock No.	Diameter	Order No.
BLPSTWR4	4" max	408005
BLPSTWR6	6" max	408006

- Adjusts to fit any circumference or irregular shape
- Grip, loosen or tighten almost anything
- Won't scratch or damage surfaces
- Cushioned grip for maximum comfort
- Heavy duty construction for longer life
- **BLPSTWRKT** (Order No.408004)**Set includes** BLPSTWR4 & BLPSTWR6



Screwdriver & Bits



Blue-Point's screwdrivers give you better grip and higher turning force with tool tip durability to match.

Handles using dual compound are ergonomically shaped to fit your palm for comfort and better grip.

The high strength Molybdenum-Vanadium steel shanks are nickel and chrome plated for toughness and corrosion resistance.

Vapor-blasted tips offer greater screw-tip adherence to prevent the rounding of screws and screwdrivers alike.

Finer details like laser-etching of the size and part numbers are not missed. This ensure permanence with continual usage over time.

We even offer three colours in the same range to facilitate tool identification and differentiation for different work-teams.

Screwdrivers 46

Bits 49

P Series, Phillips®

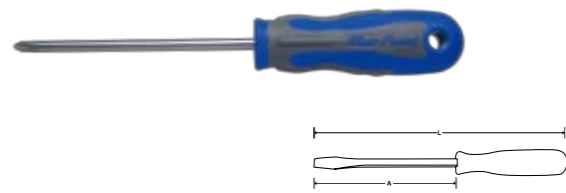

P Series, Slotted

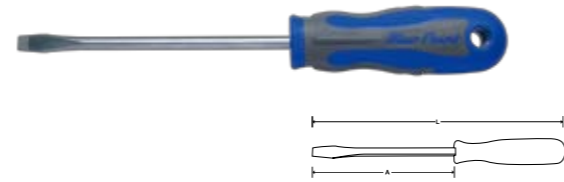

Stock No. (Blue)	Order No.	Stock No. (Yellow)	Order No.	Stock No. (Red)	Order No.	Tip Size (mm)	A (mm)	L (mm)
BSGD75PH0B	10 501001	BSGD75PH0Y	10 501030	BSGD75PH0R	10 501059	PH0	75	148
BSGD100PH0B	10 501002	BSGD100PH0Y	10 501031	BSGD100PH0R	10 501060	PH0	100	187
BSGD150PH0B	10 501003	BSGD150PH0Y	10 501032	BSGD150PH0R	10 501061	PH0	150	237
BSGD100PH1B	10 501004	BSGD100PH1Y	10 501033	BSGD100PH1R	10 501062	PH1	100	208
BSGD150PH1B	10 501005	BSGD150PH1Y	10 501034	BSGD150PH1R	10 501063	PH1	150	258
BSGD200PH1B	10 501006	BSGD200PH1Y	10 501035	BSGD200PH1R	10 501064	PH1	200	308
BSGD250PH1B	10 501007	BSGD250PH1Y	10 501036	BSGD250PH1R	10 501065	PH1	250	358
BSGD300PH1B	10 501008	BSGD300PH1Y	10 501037	BSGD300PH1R	10 501066	PH1	300	408
BSGD100PH2B	10 501009	BSGD100PH2Y	10 501038	BSGD100PH2R	10 501067	PH2	100	208
BSGD150PH2B	10 501010	BSGD150PH2Y	10 501039	BSGD150PH2R	10 501068	PH2	150	258
BSGD200PH2B	10 501011	BSGD200PH2Y	10 501040	BSGD200PH2R	10 501069	PH2	200	308
BSGD250PH2B	10 501012	BSGD250PH2Y	10 501041	BSGD250PH2R	10 501070	PH2	250	358
BSGD300PH2B	10 501013	BSGD300PH2Y	10 501042	BSGD300PH2R	10 501071	PH2	300	408
BSGD150PH3B	10 501014	BSGD150PH3Y	10 501043	BSGD150PH3R	10 501072	PH3	150	270
BSGD200PH3B	10 501015	BSGD200PH3Y	10 501044	BSGD200PH3R	10 501073	PH3	200	320

Stock No. (Blue)	Order No.	Stock No. (Yellow)	Order No.	Stock No. (Red)	Order No.	Tip Size (mm)	A (mm)	L (mm)
BSGD75S3B	10 501016	BSGD75S3Y	10 501045	BSGD75S3R	10 501074	3mm	75	147
BSGD75F4B	10 501017	BSGD75F4Y	10 501046	BSGD75F4R	10 501075	4mm	100	168
BSGD100S4B	10 501018	BSGD100S4Y	10 501047	BSGD100S4R	10 501076	4mm	125	188
BSGD125S4B	10 501019	BSGD125S4Y	10 501048	BSGD125S4R	10 501077	4mm	150	233
BSGD150S4B	10 501020	BSGD150S4Y	10 501049	BSGD150S4R	10 501078	4mm	250	308
BSGD250S4B	10 501021	BSGD250S4Y	10 501050	BSGD250S4R	10 501079	5.5mm	125	358
BSGD125S5B	10 501022	BSGD125S5Y	10 501051	BSGD125S5R	10 501080	5.5mm	150	208
BSGD150S5B	10 501023	BSGD150S5Y	10 501052	BSGD150S5R	10 501081	6.5mm	250	258
BSGD125F5B	10 501024	BSGD125F5Y	10 501053	BSGD125F5R	10 501082	4mm	75	233
BSGD125F6B	10 501025	BSGD125F6Y	10 501054	BSGD125F6R	10 501083	5.5mm	125	208
BSGD150F6B	10 501026	BSGD150F6Y	10 501055	BSGD150F6R	10 501084	6.5mm	125	258
BSGD250F6B	10 501027	BSGD250F6Y	10 501056	BSGD250F6R	10 501085	6.5mm	150	358
BSGD150F8B	10 501028	BSGD150F8Y	10 501057	BSGD150F8R	10 501086	8mm	150	270
BSGD175F8B	10 501029	BSGD175F8Y	10 501058	BSGD175F8R	10 501087	8mm	175	320

- 2-Component handle gives the screwdriver an ideal ergonomic shape
- Perfectly adapted to the forces exerted by the hand and permits work efficiently
- The chrome molybdenum vanadium blade is hardened to HRC 59±1
- Nickel and chrome plated blade and the tip is especially vapor-blasted for greater screw-tip adherence and a full anti-rust guarantee
- With hanging hole moulded to the blade
- The size and part number are laser-etched on the blade to ensure their permanence

P Series, Slotted

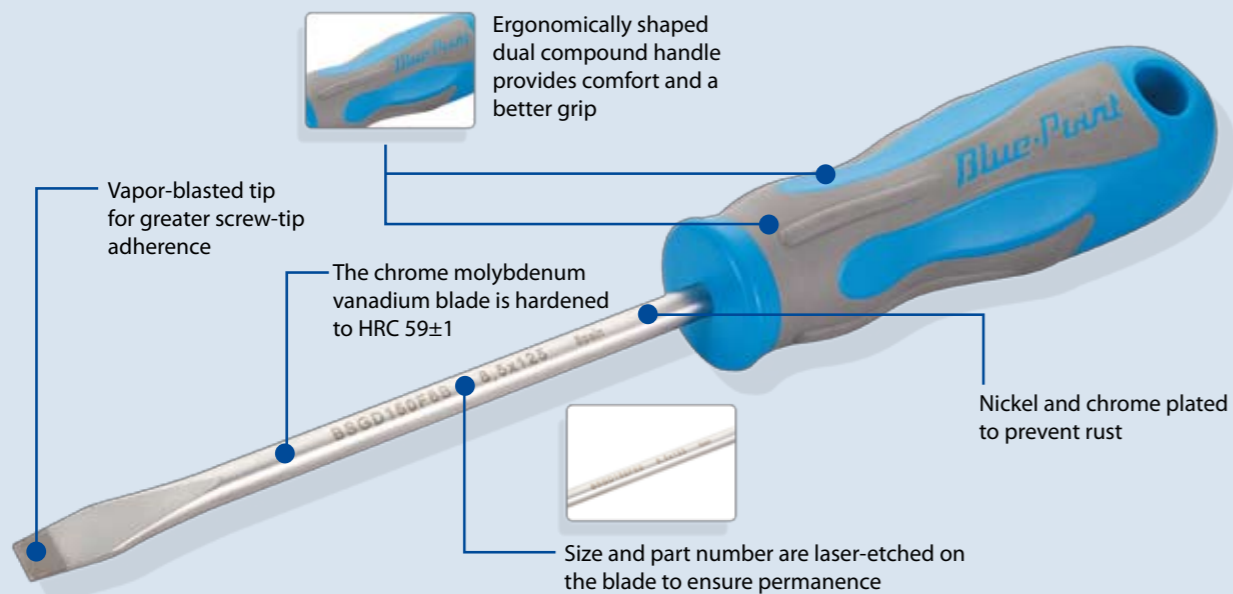

P Series VDE, Phillips®



P Series VDE, Slotted



Stock No.	Tip Size	A (mm)	L (mm)	Order No.
BSGDV100PH0	PH0	100	148	501088
BSGDV150PH1	PH1	150	188	501089
BSGDV175PH2	PH2	175	208	501090
BSGDV200PH3	PH3	200	270	501091

Stock No.	Tip Size	A (mm)	L (mm)	Order No.
BSGDV100S2	2.5mm	100	163	501092
BSGDV100S3	3mm	100	188	501093
BSGDV100S4	4mm	100	208	501094
BSGDV125S5	5.5mm	125	233	501095
BSGDV150S6	6.5mm	150	258	501096

- Insulated screwdriver for Phillips PH-head screws, for work on live equipment up to 1000V
- Examination of screwdrivers according to latest national and international standards
- Examination piece-wise in water bath with 10 KV
- Ergonomically developed 2-component handle
- Blade black oxidized, entirely hardened

1/4" Ratchet Screwdriver, Pistol Handle

Packing: 1

Order NO.: 502001

BSGDMR6



- 5" magnetic bit holder blade for 1/4" hex bits
- 45 tooth ratcheting mechanism ensures precise positioning and movement
- Bits are stored in a bit magazine inside the handle
- Includes six 1/4" hex bits: Flat Tip (4.5 and 5.5), Phillips® (#1 and #2) plus Torx® (T15 and T20)
- Ergonomically designed two component handle is textured for excellent grip and user comfort
- Provides three functional options, left and right turning and locked position
- Blade features a knurled-grip for fast spinning of the fastener
- Screwdriver carries a lifetime warranty (Bits are consumable and carry no warranty)

Ratcheting Screwdriver

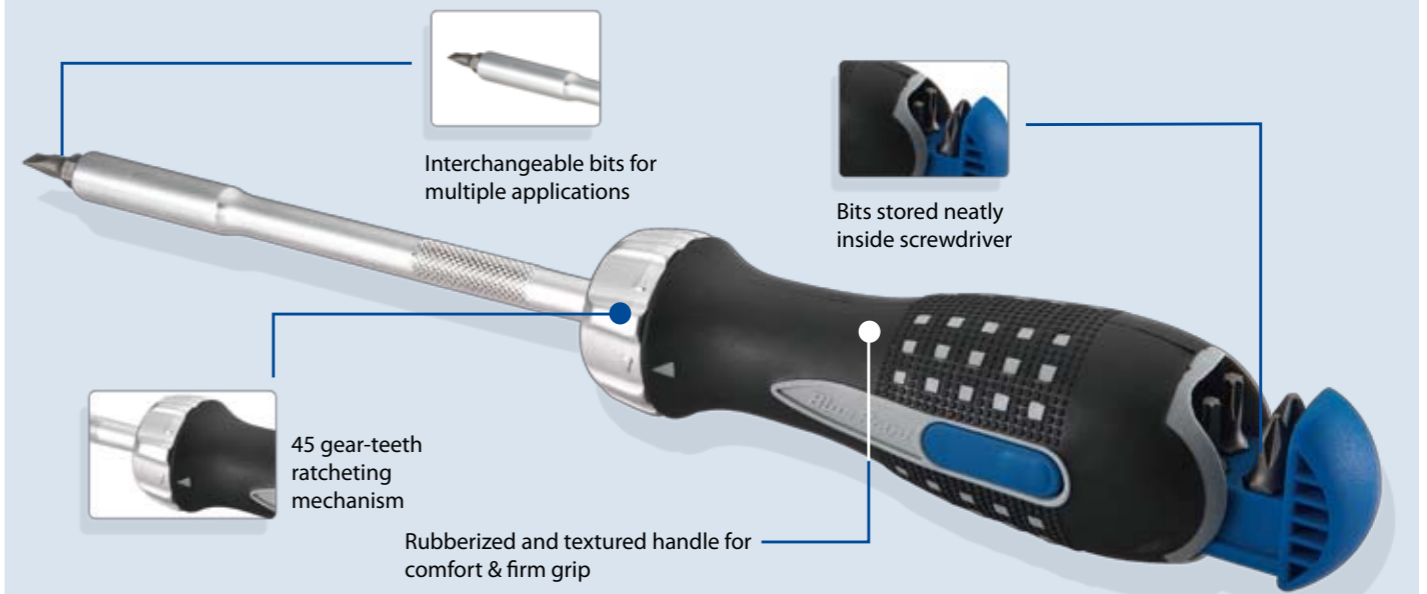

M Series, Slotted

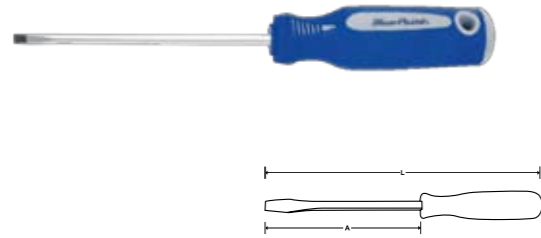

Stock No.	Tip Size (mm)	A (mm)	L (mm)	Order No.
BSGDM65F2	2.4	65	136	501097
BSGDM75F3	3.2	75	149	501098
BSGDM100F3	3.2	100	175	501099
BSGDM150F3	3.2	150	225	501100
BSGDM75F5	5	75	182	501101
BSGDM100F5	5	100	208	501102
BSGDM150F5	5	150	258	501103
BSGDM200F5	5	200	309	501104

M Series, Phillips®

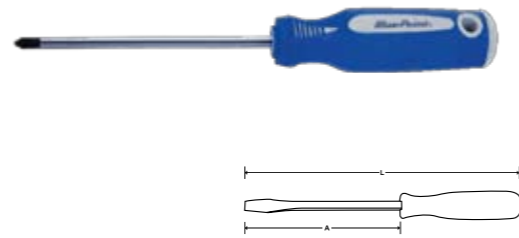

Stock No.	Tip Size (mm)	A (mm)	L (mm)	Order No.
BSGDM65PH00	00	65	136	501113
BSGDM75PH0	0	75	148	501114
BSGDM100PH0	0	100	173	501115
BSGDM150PH0	0	150	223	501116
BSGDM75PH1	1	75	181	501117
BSGDM100PH1	1	100	206	501118
BSGDM150PH1	1	150	256	501119
BSGDM38PH2	2	38	100	501120

- Tri-lobe handle shape for reducing user strain while operating and offering optimum torque
- Soft cushion grip for the best performance without fatigue
- Concave hollow of the handle neck for firm pinch pressure and precision control

M Series, Pozidriv®

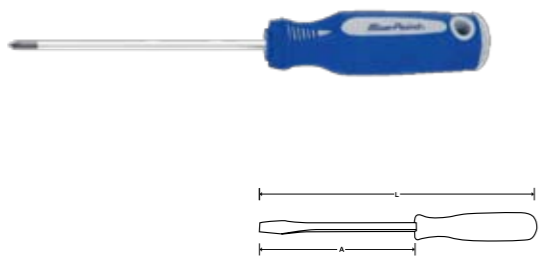

Stock No.	Tip Size (mm)	A (mm)	L (mm)	Order No.
BSGDM65PZ00	0	65	136	501128
BSGDM75PZ0	0	75	148	501129
BSGDM100PZ0	0	100	173	501130
BSGDM150PZ0	0	150	223	501131
BSGDM75PZ1	1	75	181	501132
BSGDM100PZ1	1	100	206	501133
BSGDM150PZ1	1	150	256	501134
BSGDM38PZ2	2	38	100	501135

M Series, Torx®



Stock No.	Tip Size (mm)	A (mm)	L (mm)	Order No.
BSGDM75TX6	T6	75	148	501143
BSGDM75TX7	T7	75	148	501144
BSGDM75TX8	T8	75	148	501145
BSGDM75TX9	T9	75	148	501146
BSGDM100TX10	T10	100	206	501147
BSGDM100TX15	T15	100	206	501148

- Tri-lobe handle shape for reducing user strain while operating and offering optimum torque
- Soft cushion grip for the best performance without fatigue
- Concave hollow of the handle neck for firm pinch pressure and precision control

Bits



○ Hex Bit
 ⚙️ Tamper Resistant Torx Bit
 — Flat Tip Bit
 + Phillips Tip Bit
 ■ Square Tip Bit

Stock No.	Description	Size	Order No.
BLPFB532	Flat Tip Bit	5/32"	502002
BLPFB732	Flat Tip Bit	7/32"	502003
BLPFB932	Flat Tip Bit	9/32"	502004
BLPFB316	Flat Tip Bit	3/16"	502005
BLPFB14	Flat Tip Bit	1/4"	502006
BLPPB0	Phillips Tip Bit	#0	502007
BLPPB1	Phillips Tip Bit	#1	502008
BLPPB2	Phillips Tip Bit	#2	502009
BLPPB3	Phillips Tip Bit	#3	502010
BLPHBM3	Hex Bit	3mm	502011
BLPHBM4	Hex Bit	4mm	502012
BLPHBM5	Hex Bit	5mm	502013
BLPHBM6	Hex Bit	6mm	502014
BLPHB18	Hex Bit	1/8"	502015
BLPHB964	Hex Bit	9/64"	502016
BLPHB532	Hex Bit	5/32"	502017
BLPHB316	Hex Bit	3/16"	502018
BLPHB732	Hex Bit	7/32"	502019
BLPHB14	Hex Bit	1/4"	502020
BLPTB10TP	Tamper Resistant Torx Bit	T10	502021
BLPTB15TP	Tamper Resistant Torx Bit	T15	502022
BLPTB20TP	Tamper Resistant Torx Bit	T20	502023
BLPTB25TP	Tamper Resistant Torx Bit	T25	502024
BLPTB30TP	Tamper Resistant Torx Bit	T30	502025
BLPSQB1	Square Tip Bit	#1	502026
BLPSQB2	Square Tip Bit	#2	502027



Pliers



At Blue-Point, we created a broad range of high performance pliers for most applications today while keeping at a very affordable price.

Like our screwdrivers, we also adopt a dual compound design for the handle to improve gripping comfort and reduce hand fatigue.

The joints are precision machined and located for high leverage thus requiring less effort for every crimping and cutting task.

We even use laser hardening on the cutting edges of our pliers!

Blue-Point pliers are where good quality comes at a good price. And our broad range completes your search for the right tool to the job.



Pliers Sets	52
Standard Pliers	54
VDE Pliers	60
Locking Pliers	61
Retaining Ring Pliers	62
Special Pliers	63

Pliers Set, Dipped Grips, 8pcs

Packing: 8 Order NO.: 601007

BDGPL800

Stock No.	Description	Jaw Capacity (inches)	Length (inches)	Packing	Order No.
BDGAWP100	Adjustable Joint Pliers	1 3/4	10	6	602001
BDG48CP	Slip Joint Pliers	1 27/32	8	6	602037
BDG98CP	Long Needle Nose Pliers	3	8	6	602004
BDG9845CP	45° Bent Needle Nose Pliers	2 13/16	7 3/4	6	602010
BDG57CP	Lineman's Pliers	1 1/4	7 1/2	6	602006
BDGEC7	End Cutter	7/16	7	6	602009
BDG86CP	Diagonal Cutter	2 1/32	6 1/2	6	602005
BDG88CP	Diagonal Cutter	1 5/16	8 1/8	6	602008

- Includes BDGAWP100 adjustable joint pliers, BDG48CP slip joint pliers, BDG98CP and BDG9845CP needle nose pliers, BDG57CP Lineman's pliers, BDG86CP and BDG88CP diagonal cutters plus BDGEC7 end cutters (8 pcs) in storage tray

Pliers Set, Standard, 5pcs

Packing: 5 Order NO.: 601008

BPL501

Stock No.	Description	Jaw Capacity (inches)	Length (inches)	Packing	Order No.
B48CP	Slip Joint Pliers	2 3/32	8 13/32	6	602036
B58HLP	Lineman's Pliers	1 1/2	8 11/32	6	602007
B96CP	Needle Nose Pliers	2 1/32	6 5/16	6	602003
BAWP100	Adjustable Joint Pliers	1 3/8	10 5/32	6	602038
B87CP	Diagonal Cutters	3 1/32	6 19/32	6	602002

- B48CP, B58HLP, B87CP, B96CP and BAWP100 (5 pcs.) in storage tray

Long Reach Compound Joint Pliers Set, 3pcs

Packing: 1 Order NO.: 601011

303DJCP

Stock No.	Description	Jaw Capacity (inches)	Length (inches)	Packing	Order No.
913DJBCP	45° Bent Nose Pliers	2 5/8	12 3/4	1	602033
913DJCP	Needle Nose Pliers	2 3/4	13	1	602034
613DJCP	Duck Bill Pliers	1 1/2	12 5/8	1	602035

- 913DJBCP, 913DJCP and 613DJCP (3 pcs.) in storage tray

Extended Reach Hose Grip Pliers Set, 3pcs

Packing: 3 Order NO.: 601012

BDGPL300HG

Stock No.	Description	Jaw Capacity (inches)	Length (inches)	Packing	Order No.
BDGPL410HG	Small Hose Grip Pliers	2 1/4	11	6	602030
BDGPL411HG	Medium Hose Grip Pliers	2 1/4	11	6	602031
BDGPL412HG	Large Hose Grip Pliers	2	11	6	602032

- Grips are double dipped offering increased comfort and control during use
- Pliers extra length provides additional access to otherwise difficult to reach areas
- Corrosion resistant finish
- Leaf springs improve maneuverability

Mini Pliers Set, 10pcs

Packing: 10 Order NO.: 601009

BMPL1000

Stock No.	Description	Jaw Capacity (inches)	Length (inches)	Packing	Order No.
B45CMP	Combination Pliers	1	4 11/16	6	602011
B65CMP	Duck Bill Pliers	1 5/32	4 7/8	6	602014
B75CMP	Round Nose Pliers	1 5/32	5	6	602017
B85CMP	Diagonal Cutter	2 1/32	4 11/32	6	602015
B85CTMP	Thin Diagonal Cutter	2 3/32	4 5/8	6	602020
B945CMP	45° Bent Nose Pliers	1	4 11/16	6	602013
B95CMP	Long Nose Pliers	1 1/8	4 7/8	6	602012
B95CLMP	Long Needle Nose Pliers	2 1/16	5 25/32	6	602019
B960CMP	60° Bent Nose Pliers	1 5/16	4 11/16	6	602018
BMPEC5	End Cutter	5/16	4 1/32	6	602016

- B45CMP, B65CMP, B75CMP, B85CMP, B85CTMP, B945CMP, B95CLMP, B95CMP, B960CMP and BMPEC5 (10 pcs.) in storage tray

Long Reach Miniature Pliers Set, 4pcs

Packing: 4 Order NO.: 601010

BDGPL400LMP

Stock No.	Description	Jaw Capacity (inches)	Length (inches)	Packing	Order No.
BDG96LMP	Long Nose Pliers	1 5/16	6	6	602021
BDG97LMP	Needle Nose Pliers	2 13/32	7	6	602022
BDG9645LMP	45° Bent Nose Pliers	1 7/32	6	6	602023
BDG86LMP	Diagonal Cutting Pliers	3/4	5 1/2	6	602024

- Set includes BDG86LMP cutters plus BDG96LMP, BDG9645LMP and BDG97LMP pliers (4 pcs)
- Chrome nickel finish prevents against rust and corrosion
- Cushioned grips offer comfort during extended use
- Vinyl grips provide easy cleanup and durability
- Pliers exceed ANSI standards

Long Reach Pliers Set, 3pcs

Packing: 3 Order NO.: 601013

BDGPL300LR

Stock No.	Description	Jaw Capacity (inches)	Length (inches)	Packing	Order No.
BDG311CP	Diagonal Cutter	1 9/16	11	6	602025
BDG91145CP	45° Bent Needle Nose Pliers	3 3/16	11	6	602026
BDG911CP	Needle Nose Pliers	3 9/16	11	6	602027

- BDG911CP and BDG91145CP pliers plus BDG311CP cutters (3 pcs) in storage tray

Extra Long Reach Pliers Set, 2pcs

Packing: 2 Order NO.: 601014

BDGPL200XLR

Stock No.	Description	Jaw Capacity (inches)	Length (inches)	Packing	Order No.
BDG91645CP	45° Bent Needle Nose Pliers	3 3/16	16	6	602028
BDG916CP	Needle Nose Pliers	3 9/16	16	6	602029

- BDG916CP and BDG91645CP (2 pcs) in storage tray

Retaining Ring Pliers Set, 2pcs

Packing: 1 Order NO.: 601001

PR36

Stock No.	Length (inches)	Ring Size Range (inches)	Tip Kit Included	Order No.
PR37	6 1/4	Internal 3/8 - 2	PR5 (For PR36 only)	1
PR38	6 1/4	External 1/4 - 2	—	1
Tip Sizes Included Inches/Degree		Optional Kits	Optional Tip Sizes	Order No.
PR37	2 pair each in PR36 set: .047" 0°, .070" 0°, .047" 45°, .039" 90°	PR5	.047" 0°, .070" 0°, .047" 45°, .039" 90°	605001
PR38	—	PR5	.047" 0°, .070" 0°, .047" 45°, .039" 90°	605002

- Includes PR37 and PR38 pliers plus tips

Retaining Ring Pliers Set, 3pcs

Packing: 1 Order NO.: 601003

PRH503

Stock No.	Length (inches)	Ring Size Range (inches)	Order No.	Tip Kit Included	Tip Sizes Included Degree
PRH56A (Convertible)	6 3/8	Internal 1/4 - 1 External 1/8 - 1	6 605003	PRH56A-1	1 pair each: .023" 0°, .036" 0°, .047" 0°, .036" 90°, .047" 90°
PRH57A (Convertible)	8	Internal 3/8 - 2 External 1/4 - 2	6 605004	PRH57A-1	1 pair each: .036" 0°, .047" 0°, .070" 0°, .036" 90°, .047" 90°
PRC65A (Convertible)	10	Internal 1 1/8 - 4 External 1 1/8 - 4	6 605005	PRC65A-1	1 pair each: .090", .108", .120" (15° and 90°)

- Includes PRH56A, PRH57A and PRC65A retaining ring
- **PRH502A** (Order No. 601002) set includes PRH56A and PRH57A retaining ring pliers
- Pliers in storage case

Slip Joint Pliers, Dipped Grip

Packing: 6 Order NO.: 602037

BDG48CP

Stock No.	Description	Jaw Capacity (inches)	Length (inches)
BDG48CP	Slip Joint Pliers	1 27/32	8

- Dipped grips deliver optimal comfort during high strength gripping
- Drop forged chrome/nickel alloy is fine polished for corrosion resistant finish

End Cutter

Packing: 6 Order NO.: 602009

BDGEC7

Stock No.	Description	Jaw Length (inches)	Length (inches)
BDGEC7	End Cutter	7/16	7

Adjustable Joint Pliers, Dipped Grip

Packing: 6 Order NO.: 602001

BDGAWP100

Stock No.	Description	Jaw Capacity (inches)	Length (inches)
BDGAWP100	Adjustable Joint Pliers	1 3/4	10

Retaining Ring Pliers Set, 2pcs

Packing: 1 Order NO.: 601004

PR50A

Stock No.	Length (inches)	Ring Size Range (inches)	Tip Kit Included	Order No.
PR51	9 1/2	2 7/16 - 4	PR502	1 605006
PR52	9 1/2	1 1/2 - 3 11/32	PR507	1 605007
Tip Sizes Included Inches/Degree		Optional Kits	Optional Tip Sizes	Order No.
PR51	.108", 15°	PR501	.108", 0°	
PR52	.120", 45°	PR505	.120", 0°	

- Includes PR51 and PR52 pliers plus tips in a plastic case

Diagonal Cutter

Packing: 1 Order NO.: 602005

BDG86CP

Stock No.	Description	Jaw Capacity (inches)	Length (inches)	Order No.
BDG86CP	Diagonal Cutter	2 1/32	6 1/2	6 602005
BDG88CP	Diagonal Cutter	1 5/16	8 1/8	6 602008
BDGCT6K	Diagonal Cutting pliers, Dipped Grip	7/16	6	6 602048

- Dipped grips deliver optimal comfort during high strength gripping
- Drop forged chrome/nickel alloy is fine polished for corrosion resistant finish

Combination Pliers

Packing: 1 Order NO.: 602006

BDG57CP

Stock No.	Description	Jaw Capacity (inches)	Length (inches)	Order No.
BDG57CP	Combination Pliers	1 1/4	7 1/2	6 602006
BDGCB8K	Combination Pliers, Dipped Grip	7/8	8	6 602050
BDGCB9HK	Combination Pliers, Dipped Grip, High-Leverage	7/8	9	6 602051

- Dipped grips deliver optimal comfort during high strength gripping
- Drop forged chrome/nickel alloy is fine polished for corrosion resistant finish

Long Needle Nose Pliers

Packing: 6 Order NO.: 602004

BDG98CP

Stock No.	Description	Jaw Capacity (inches)	Length (inches)
BDG98CP	Long Needle Nose Pliers	3	8

- Dipped grips deliver optimal comfort during high strength gripping
- Drop forged chrome/nickel alloy is fine polished for corrosion resistant finish

45° Bent Needle Nose Pliers

Packing: 6 Order NO.: 602010

BDG9845CP

Stock No.	Description	Jaw Capacity (inches)	Length (inches)
BDG9845CP	45° Bent Needle Nose Pliers	2 13/16	7 3/4

- Dipped grips deliver optimal comfort during high strength gripping
- Drop forged chrome/nickel alloy is fine polished for corrosion resistant finish

Needle Nose Pliers, Dipped Grip

Packing: 6 Order NO.: 602049

BDGLN6K

Stock No.	Description	Jaw Capacity (inches)	Length (inches)
BDGLN6K	Needle Nose Pliers, Dipped Grip	1	6

- Dipped grips deliver optimal comfort during high strength gripping
- Drop forged chrome/nickel alloy is fine polished for corrosion resistant finish

Diagonal Cutter

Combination Pliers

Slip Joint Pliers

Needle Nose Pliers

Adjustable Joint Pliers

Adjustable Joint Pliers



New



New



B48CP



New



BDMAJ10

New



BAWP100

Stock No.	Description	Jaw Capacity (inches)	Length (inches)	Packing	Order No.
B87CP	Side Cutter	3 ¹ / ₃₂	6 ¹⁹ / ₃₂	6	602002
BDMCT5	Diagonal Cutting Pliers	5 ¹ / ₁₆	5	6	602045
BDMCT6	Diagonal Cutting Pliers	7 ¹ / ₁₆	6	6	602046
BDMCT7	Diagonal Cutting Pliers	1 ¹ / ₂	7	6	602047

Stock No.	Description	Jaw Capacity (inches)	Length (inches)	Packing	Order No.
B58HLP	Combination Pliers	1 ¹ / ₂	8 ³¹ / ₃₂	6	602007
BDMCB6	Combination Pliers	5 ¹ / ₈	6	6	602039
BDMCB7	Combination Pliers	5 ¹ / ₈	7	6	602040
BDMCB8	Combination Pliers	7 ¹ / ₈	8	6	602041

Stock No.	Description	Jaw Capacity (inches)	Length (inches)
B48CP	Slip Joint Plier	2 ³ / ₃₂	8 ¹³ / ₃₂

Stock No.	Description	Jaw Capacity (inches)	Length (inches)	Packing	Order No.
B96CP	Needle Nose Pliers	2 ¹ / ₃₂	6 ⁵ / ₁₆	6	602003
BDMLN6	Needle Nose Pliers	1	6	6	602042
BDMLN8	Needle Nose Pliers	1 ¹ / ₈	8	6	602043

Stock No.	Description	Jaw Capacity (inches)	Length (inches)
BDMAJ10	Adjustable Joint Pliers	1 ¹¹ / ₁₆	10

Stock No.	Description	Jaw Capacity (inches)	Length (inches)
BAWP100	Adjustable Joint Pliers	1 ³ / ₈	10 ⁵ / ₃₂

- Soft grip handles provide comfort and control
- Drop forged chrome/nickel alloy is fine polished for corrosion resistant finish

- Soft grip handles provide comfort and control
- Drop forged chrome/nickel alloy is fine polished for corrosion resistant finish

Combination Pliers



Dual-compound soft-grip handles for improved comfort



Precise machined joint for ease of use and longer life



High leverage grip for tubular gripping applications



Tougher steel for cutting harder and thicker wire, laser sharpened & treated cutting edge for less cutting effort

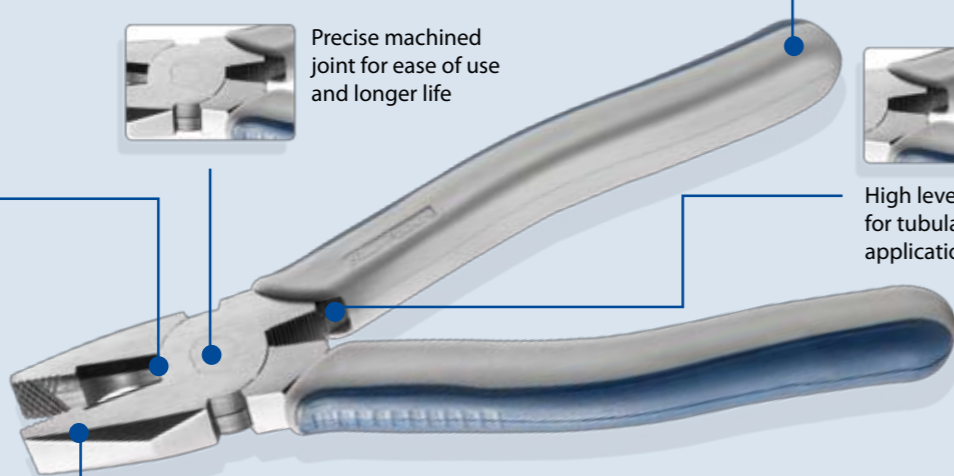

Differential jaws for more secure grip

Mini Round Nose Pliers

Mini Cutter

Mini Thin Diagonal Cutter

Packing: 6 Order NO.: 602017

Packing: 6 Order NO.: 602015

Packing: 6 Order NO.: 602020

B75CMP

B85CMP

B85CTMP



Stock No.	Description	Jaw Capacity (inches)	Length (inches)
B75CMP	Mini Round Nose Pliers	1 ⁵ / ₃₂	5

Stock No.	Description	Jaw Capacity (inches)	Length (inches)
B85CMP	Mini Cutter	2 ¹ / ₃₂	4 ¹¹ / ₃₂

Stock No.	Description	Jaw Capacity (inches)	Length (inches)
B85CTMP	Mini Thin Diagonal Cutter	2 ³ / ₃₂	4 ⁵ / ₈

- Soft grip handles provide comfort and control
- Drop forged chrome/nickel alloy is fine polished for corrosion resistant finish

Mini Combination Pliers

Packing: 6 Order NO.: 602011

B45CMP

Stock No.	Description	Jaw Capacity (inches)	Length (inches)
B45CMP	Mini Combination Pliers	1	4 ¹¹ / ₁₆

- Soft grip handles provide comfort and control
- Drop forged chrome/nickel alloy is fine polished for corrosion resistant finish

Mini Curved Long Nose Pliers

Packing: 6 Order NO.: 602013

B945CMP

Stock No.	Description	Jaw Capacity (inches)	Length (inches)
B945CMP	Mini curved Long Nose Pliers	1	4 ¹¹ / ₁₆

Mini Long Nose Pliers

Packing: 6 Order NO.: 602012

B95CMP

Stock No.	Description	Jaw Capacity (inches)	Length (inches)
B95CMP	Mini Long Nose Pliers	1 ¹ / ₈	4 ⁷ / ₈

Mini 60° Bent Nose Pliers

Packing: 6 Order NO.: 602018

B960CMP

Stock No.	Description	Jaw Capacity (inches)	Length (inches)
B960CMP	Mini 60° Bent Nose Pliers	1 ⁵ / ₁₆	4 ¹¹ / ₁₆

- Soft grip handles provide comfort and control
- Drop forged chrome/nickel alloy is fine polished for corrosion resistant finish

Mini Pincer

Packing: 6 Order NO.: 602016

BMPECS

Stock No.	Description	Jaw Capacity (inches)	Length (inches)
BMPECS	Mini Pincer	⁵ / ₁₆	4 ¹ / ₃₂

Mini Long Needle Nose Pliers

Packing: 6 Order NO.: 602019

B95CLMP

Stock No.	Description	Jaw Capacity (inches)	Length (inches)
B95CLMP	Mini Long Needle Nose Pliers	2 ¹ / ₁₆	5 ²⁵ / ₃₂

- Soft molded handles deliver optimal comfort during high strength gripping
- Drop forged chrome/nickel alloy is fine polished for corrosion resistant finish

Mini Duck Bill Pliers

Packing: 6 Order NO.: 602014

B65CMP

Stock No.	Description	Jaw Capacity (inches)	Length (inches)
B65CMP	Mini Duck Bill Pliers	1 ³ / ₃₂	4 ⁷ / ₈

Diagonal Cutting Pliers



Soft grip handles provide comfort and control



Tougher steel for cutting harder and thicker wire, laser sharpened & treated cutting edge for less cutting effort



Drop forged chrome/nickel alloy is fine polished for corrosion resistant finish

Long Nose Pliers

Combination Pliers



Stock No.	Description	Length (mm)	Box	Order No.
WT1001-6	Long Nose Pliers	160	6	603005
WT1001-8	Long Nose Pliers	200	6	603006

Stock No.	Description	Length (mm)	Box	Order No.
WT1014-6	Combination Pliers	160	6	603001
WT1014-7	Combination Pliers	180	6	603002
WT1014-8	Combination Pliers	200	6	603003
WT5414-9	Combination Pliers, Heavy Duty	225	6	603004

- Chrome vanadium steel
- All tools are tested under 10,000 Voltage testing machine
- Special designed soft grips

Locking Pliers

Locking Pliers, Soft Grip



Stock No.	Description	Grip Style	Jaw Capacity (inches)	Length (inches)	Box	Order No.
BLP5	Curved Jaw	Standard	1 1/8	5	1	604001
BLP7	Curved Jaw	Standard	1 5/8	7	1	604002
BLP10	Curved Jaw	Standard	1 7/8	10	1	604003
BLP6LN	Long Nose	Standard	2 1/4	6	1	604004

- **BLP404**(Order No.601005) includes BLP5, BLP7 and BLP10 curved jaw pliers plus BLP6LN long nose pliers (4 pcs) in kit bag

Stock No.	Description	Grip Style	Jaw Capacity (inches)	Length (inches)	Box	Order No.
BSGLP5	Curved Jaw	Soft	1 1/8	5	1	604005
BSGLP7	Curved Jaw	Soft	1 5/8	7	1	604006
BSGLP10	Curved Jaw	Soft	1 7/8	10	1	604007
BSGLP6LN	Long Nose	Soft	2 1/4	6	1	604008

- **BSGLP404**(Order No.601006) includes BSGLP5, BSGLP7 and BSGLP10 curved jaw pliers plus BSGLP6LN long nose pliers (4 pcs) in kit bag

Side Cutter

Wire Stripping Pliers

Slip Joint Pliers



Stock No.	Description	Length (mm)	Box	Order No.
WT1003-6	Side Cutter	160	6	603007
WT5403-8	Side Cutter	160	6	603008

Stock No.	Description	Length (mm)	Box	Order No.
WT1017C-6	Wire Stripping Pliers	160	6	603009

Stock No.	Slip Joint Pliers	Length (mm)	Box	Order No.
WT8627-10	Slip Joint Pliers	250	6	603010

- Chrome vanadium steel
- All tools are tested under 10,000 Voltage testing machine
- Special designed soft grips

Straight Jaws

Straight Jaws, Soft Grip

C-Clamp Locking Pliers



Stock No.	Description	Jaw Capacity (inches)	Length (inches)	Box	Order No.
BDGLP7S	Straight Jaws	1 5/16	7	6	604013
BDGLP10S	Straight Jaws	1 3/4	10	6	604014

- Exceed ASME specification
- Straight jaws with maximum contact area
- Nickel plated to resist corrosion
- Convenient, one hand release lever

Stock No.	Description	Jaw Capacity (inches)	Length (inches)	Box	Order No.
BDMLP7S	Straight Jaws, Soft Grip	1 5/16	7	6	604015
BDMLP10S	Straight Jaws, Soft Grip	1 3/4	10	6	604016

- Exceed ASME specification
- Straight jaws with maximum contact area
- Nickel plated to resist corrosion
- Convenient, one hand release lever
- Non-slip cushion grip

	Stock No.	Jaw Capacity (inches)	Length (inches)	Box	Order No.
Standard Tip	VGP12406	2 5/16	6	1	807020
	VGP12412	3 5/16	12	1	604011
	VGP12418	10 1/4	18	1	807021
	VGP12424	15 11/16	24	1	807022
Swivel Tip	VGP22406	1 5/16	6	1	807023
	VGP22412	3 15/16	12	1	807024
	VGP22418	9 7/16	18	1	807025
	VGP22424	15 11/16	24	1	807026

- Quick and easy handling clamps for autobody and metal fabrication applications
- Spring-loaded release lever permits quick "NO PINCH" release even when tool is firmly locked
- Locking nut allows setting for repetitive jobs

Locking U-Clamp Pliers

Packing: 1 Order NO.: 604009

VGP12509



Stock No.	Jaw Capacity (inches)	Length (inches)
VGP12509	2 5/16	9

- U-shaped jaws allow access and perfect visibility when welding
- E-coat provides extra resistance against corrosion and welding splatter
- Quality cold-rolled steel ensures years of service
- Drop forged jaws ensure a tough, durable tool
- Smooth rounded edges allow comfortable handling and reduce risk of injury
- Spring-loaded release lever permits quick "NO PINCH" release even when tool is firmly locked
- Piano wire spring provides smooth jaw opening
- Adjustment bolt features deep knurl to accommodate greasy hands
- Locking nut allows setting for repetitive jobs
- Drilled (not punched) holes in mobile jaw ensure maximum bearing with rivets for smooth action
- Large diameter rivets add strength and durability

Sheet Metal Locking Pliers

Packing: 1 Order NO.: 604010

VGP12808



Stock No.	Jaw Capacity (inches)	Length (inches)
VGP12808	1 3/4	8

- Wide jaws allow clamping, bending, forming and crimping of sheet metal without gripping effort
- E-coat provides extra resistance against corrosion and welding splatter
- Quality cold-rolled steel ensures years of service
- Drop forged jaws ensure a tough, durable tool
- Smooth rounded edges allow comfortable handling and reduce risk of injury
- Spring-loaded release lever permits quick "NO PINCH" release even when tool is firmly locked
- Piano wire spring provides smooth jaw opening
- Adjustment bolt features deep knurl to accommodate greasy hands
- Locking nut allows setting for repetitive jobs
- Drilled (not punched) holes in mobile jaw ensure maximum bearing with rivets for smooth action
- Large diameter rivets add strength and durability

Chain Style Locking Pliers

Packing: 1 Order NO.: 604012

VGP18110



Stock No.	Chain Capacity (inches)	Handle Length (inches)
VGP18110	up to 6 9/32	9 27/32

- Wraps around and holds irregular shaped objects like oil filters and mufflers quickly and easily

Circlip Pliers, Straight



Stock No.	Description	Size Range (mm)	Length (inches)	Order No.
BCES7	External Circlip Pliers, Straight	19-60	7	605012
BCES9	External Circlip Pliers, Straight	40-100	9	605013
BCIS7	Internal Circlip Pliers, Straight	19-60	7	605016
BCIS9	Internal Circlip Pliers, Straight	40-100	9	605017

Circlip Pliers, Bent



Stock No.	Description	Size Range (mm)	Length (inches)	Order No.
BCER7	External Circlip Pliers, 90 degrees	19-60	7	605014
BCER9	External Circlip Pliers, 90 degrees	40-100	9	605015
BCIR7	Internal Circlip Pliers, 90 degrees	19-60	7	605018
BCIR9	Internal Circlip Pliers, 90 degrees	40-100	9	605019

Retaining Ring Pliers, Internal

Packing: 1 Order NO.: 605008

PR7



Tip Kit Included	Tip Sizes Included	Optional Kits	Optional Tip Sizes
PR7-1	.120°, 0°	PR7-2	.120°, 45°
Optional Kits	Optional Tip Sizes	Length (inches)	Ring Size Range (inches)
PR7-3	.120°, 90°	15 11/16	3 1/16 - 6 1/4

- Retaining ring pliers, interchangeable tip

Retaining Ring Pliers, External

Packing: 1 Order NO.: 605009

PR8



Tip Kit Included	Tip Sizes Included	Optional Kits	Optional Tip Sizes
PR7-1	.120°, 0°	PR7-2	.120°, 45°
Optional Kits	Optional Tip Sizes	Length (inches)	Ring Size Range (inches)
PR7-3	.120°, 90°	15 11/16	3 1/16 - 6 1/4

- Retaining ring pliers, interchangeable tip

Retaining Ring Pliers, Internal

Packing: 1 Order NO.: 605010

PR54



Tip Kit Included	Tip Sizes Included	Optional Kits	Optional Tip Sizes
PR54-1	.150°, 0°	PR54-2	.150°, 45°
Optional Kits	Optional Tip Sizes	Length (inches)	Ring Size Range (inches)
PR54-3	.150°, 90°	29	6 1/2 - 10

- Retaining ring pliers, interchangeable tip, internal, 29"

Retaining Ring Pliers, External

Packing: 1 Order NO.: 605011

PR53



Tip Kit Included	Tip Sizes Included	Optional Kits	Optional Tip Sizes
PR53-1	.170°, 0°	PR53-2	.170°, 45°
Optional Kits	Optional Tip Sizes	Length (inches)	Ring Size Range (inches)
PR53-3	.170°, 90°	19	6 1/2 - 10

- Retaining ring pliers, interchangeable tip, external, 19"

Bolt Cutter, Heavy Duty



Stock No.	Capacity (Soft Material) (inches)	Capacity (Hard Material) (inches)	Length (inches)	Weight (kg)	Order No.
BLPBC18	3/8	1/4	18	1.55	2 606001
BLPBC24	7/16	5/16	24	2.55	2 606002
BLPBC30	1/2	3/8	30	3.9	1 606003
BLPBC36	9/16	7/16	36	6.45	1 606004

- Ideal for cutting rod, bolts, concrete form ties and fencing wire
- Hardened alloy steel jaws
- Center cut jaw configuration provides balance while cutting
- Cuts soft or hard materials
- Rubber gripped steel handles ensure firm grip during use

Bolt Cutter Replacement Jaws



Stock No.	Description	Order No.
BLPBC18-1	Bolt Cutter Replacement Jaws, 18"	1 606005
BLPBC24-1	Bolt Cutter Replacement Jaws, 24"	1 606006
BLPBC30-1	Bolt Cutter Replacement Jaws, 30"	1 606007
BLPBC36-1	Bolt Cutter Replacement Jaws, 36"	1 606008



Torque Tools



Our torque wrenches are made in the USA where the best torque products come from.

Each unit is factory calibrated and certified to meet ASME specified accuracy on a torque standard traceable to the National Institute of Standards and Technology.

Designs like the sealed high strength ratchet head keeps out dirt and moisture in the harshest environment giving you a reliable tool that constantly deliver accurate results.

Its internal mechanism is also permanently lubricated during assembly for a trouble free service life.

You can thus be assured of accuracy, reliability and a maintenance-free equipment when getting our torque products.

Adjustable Click Type	66
Pre-set Click Type	66
Electronic Type	68
Digital Torque Testers	69

Adjustable Click Type Torque Wrench

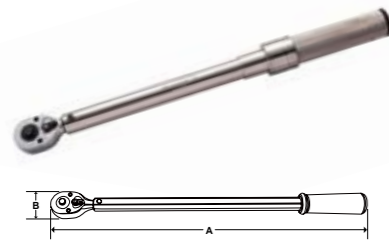

Pre-set Click Type Torque Wrench, Ratcheting

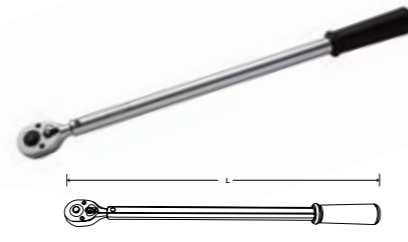

Stock No.	Square Drive (inches)	Range (Nm)	Range (Ft.Lb)	Increment (Nm)	A (mm)	B (mm)	Weight (g)	Order No.
BP501NMRMH	1/4	1.0-5.0	1-4	0.06	258	27	386	203001
BP2502NMRMH	3/8	4.0-27.7	3-20	0.12	286	27	431	203002
BP602NMRMH	3/8	10-60	8-45	0.5	406	36	1,134	203003
BP1002NMRMH	3/8	20-100	15-75	0.5	406	36	1,134	203004
BP2003NMRMH	1/2	40-200	30-150	2	483	43	1,474	203005
BP3403NMRMH	1/2	60-340	45-250	2	620	43	1,542	203006
BP8004NMRMH	3/4	150-800	110-600	5	1,067	64	5,375	203007
BP15005NMRMH	1	300-1500	220-1100	10	1,778	76	11,385	203008

- Dual scale, calibrated dual direction
- Positive lock with spring loaded pull down lock ring
- Fast, accurate and easy to set
- Easy-to-read laser marked scales
- Most feature quick release buttons which provide good socket retention as well as easy socket removal
- Accuracy: ± 3% CW ± 4% CCW of indicated value, CW, from 20% to 100% of full scale
- Meets or exceeds ASME B107.14-2004, ISO 6789 standards
- Individually serialized with matching certificate of calibration traceable to N.I.S.T.

Stock No.	Square Drive (inches)	Range (Nm)	Range (Ft.Lb.)	Range (In.Lb.)	Range (MKg)	Length (mm)	Weight (g)	Order No.
BP5T-1R	1/4	2-7	1-5	12-60	0.10-0.70	165	227	204001
BP10T-2R	3/8	4-12	3-9	36-108	0.42-1.24	184	397	204002
BP50T-2R	3/8	13-67	10-50	120-600	1.25-7.00	292	680	204003
BP100T-3R	1/2	60-200	45-150	540-1800	6.00-20.00	502	1,247	204004
BP200T-3R	1/2	60-270	45-200	540-2400	6.00-27.00	603	1,361	204005
BP300T-4R	3/4	140-420	100-300	1200-3600	14.00-42.00	711	2,155	204006
BP600T-4R	3/4	280-830	200-600	2400-7200	28.00-83.00	1,321	5,443	204007

- Torques in both left and right hand directions
- Accuracy: ± 3% CW ± 4% CCW of indicated value
- Automatic re-set when force on handle is released
- Torque limiting positive sensory "click" when pre-set
- Smooth knurled steel hand hold for comfortable, safe grip
- Handle length proportioned to torque range of wrench for minimum user fatigue
- Tamper proof torque setting for production line use
- Torque values can be calibrated in English and Metric settings
- All parts are made of alloy steel for maximum life and calibration retention
- Square drives meet industrial requirements and government specifications

Pre-set Click Type Torque Wrench, Interchangeable Head

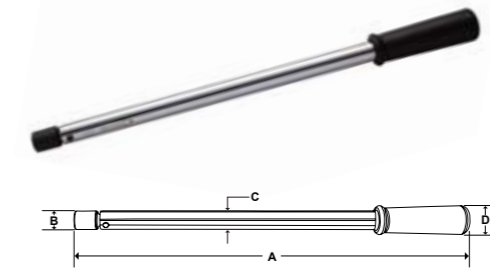

Stock No.	Shank Size	English Range	Range (Nm)	A (mm)	B (mm)	C (mm)	D (mm)	Weight (g)	Order No.
BP5T-I	J	10-50 in.lb.	1.1-5.6	165	16	15	25	159	204008
BP10T-I	J	50-250 in.lb.	5.6-28	254	16	15	25	249	204009
BP105T-I	J	60-300 in.lb.	6.8-34	157	17	22	36	340	204010
BP50T-I	J	15-75 ft.lb.	20-102	279	17	22	36	635	204011
BP100T-I	Y	30-150 ft.lb.	41-203	495	24	22	36	1,043	204012
BP200T-I	Y	40-200 ft.lb.	54-271	597	24	22	36	1,179	204013
BP300T-I	X	100-300 ft.lb.	135-406	704	28	25	36	1,769	204014
BP600T-I*	Z	120-600 ft.lb.	162-814	1,397	38	32	32	4,740	204015

- Eight models available with torque ranges from 10 in. lb. to 600 ft. lb.
- Featuring a durable, non-slip cushion grip
- Uses universal round shank heads
- Audible click and feel impulse torque control mechanism
- Tamper proof torque setting for production line use
- Torque values can be calibrated in english or metric setting
- Accuracy: ± 4% of indicated value, from 20% to 100% of full scale
- Meets or exceeds ASME B107.14-2004, ISO 6789
- Calibration certificate available at additional cost

Ratcheting Interchangeable Head



Center of fastener to retaining pin:
 * J Series - 2.50"
 * Y Series - 3.00"
 * X Series - 4.50"
 * Z Series - 5.75"

Allow use of torque wrench bodies with sockets, crowfoot wrenches, or other similar attachment.

Square Drive (inches)	Shank Size J	Shank Size Y	Shank Size X	Shank Size Z	Head O.D. (mm)	Depth (mm)	Ratchet Service Kit
1/4	QJD8A-72* (350)	—	—	—	3	3.5	RKRT936
3/8	QJD12A* (900)	QYD12A* (1,200)	—	—	17	4.4	RKRF936
1/2	QJD16A* (900)	QYD16A* (2,400)	QXD16A* (3,000)	—	17	4.4	RKRS936
3/4	—	—	QXD24A (3,600)	QZD24B (7,200)	20	4.4	RKRCQ4
1	—	—	QXD32A (3,600)	QZD32B (7,200)	20	4.4	RKRCQ5

* U.S. Patent 6,125,722 applies to these ratchet heads
 Value in parentheses in chart is the Maximum Recommended Working Torque, in. lb.

Open End Head, mm



Center of fastener to retaining pin:
 * J Series - 2.50"
 * Y Series - 3.00"
 * X Series - 4.50"
 * Z Series - 5.75"

Allow use of torque wrench bodies with sockets, crowfoot wrenches, or other similar attachment.

mm	Shank Size J	Shank Size Y	Shank Size X	Shank Size Z	Head O.D. (mm)	Head Depth (mm)	mm	Shank Size J	Shank Size Y	Shank Size X	Shank Size Z	Head O.D. (mm)	Head Depth (mm)
6	QJOM6A (60)	—	—	—	13.5	3.6	20	—	QYOM20A (1,925)	QXOM20A (1,925)	—	43.7	9.2
7	QJOM7A (75)	—	—	—	13.5	3.6	21	QJOM21A (900)	QYOM21A (2,160)	QXOM21A (2,160)	—	43.7	9.2
8	QJOM8A (120)	—	—	—	16.5	3.3	22	QJOM22A (900)	QYOM22A (2,400)	QXOM22A (2,470)	—	43.7	9.2
9	QJOM9A (170)	—	—	—	19.8	4.8	23	QJOM23A (900)	QYOM23A (2,400)	QXOM23A (2,745)	—	47	10
10	QJOM10A (265)	—	—	—	19.8	4.8	24	QJOM24A (900)	QYOM24A (2,400)	QXOM24A (2,970)	QZOM24A (2,970)	49	11
11	QJOM11A (400)	—	—	—	22.9	5.6	25	QJOM25A (900)	QYOM25A (2,400)	—	QZOM25A (3,295)	52	11
12	QJOM12A (430)	—	—	—	26.9	6.1	26	QJOM26A (900)	—	QXOM26A (3,570)	QZOM26A (3,570)	53	11
13	QJOM13A (495)	—	—	—	26.9	6.1	27	QJOM27A (900)	QYOM27A (2,400)	—	QZOM27A (3,825)	55	12
14	QJOM14A (665)	QYOM14A (665)	—	—	29.5	6.6	29	—	QYOM29A (2,400)	QXOM29A (3,600)	QZOM29A (4,550)	58	12
15	QJOM15A (885)	QYOM15A (885)	—	—	33.3	6.9	30	—	QYOM30A (2,400)	QXOM30A (3,600)	QZOM30A (4,950)	61	13
16	QJOM16A (900)	QYOM16A (1,060)	—	—	33.3	6.9	32	—	QYOM32A (2,400)	QXOM32A (3,600)	QZOM32A (5,755)	65	14
17	QJOM17A (900)	QYOM17A (1,235)	—	—	37.1	7.3	34	—	QYOM34A (2,400)	QXOM34A (3,600)	QZOM34A (6,595)	68	14
18	QJOM18A (900)	QYOM18A (1,375)	QXOM18A (1,375)	—	37.1	7.3	36	—	QYOM36A (2,400)	QXOM36A (3,600)	QZOM36A (7,200)	74	15
19	QJOM19A (900)	QYOM19A (1,650)	QXOM19A (1,650)	—	40.4	7.6							

* Value in parentheses is the Maximum Recommended Working Torque, in. lb.

CompuTorq 3 Digital Torque Wrench



- Sleek new design
- 15-degree flex ratcheting head
- Push button socket release head
- Large, easy to read digital display
- Long battery life, uses 2 each CR123 lithium batteries
- Ergonomically designed molded non-slip rubber grip
- Torques in both clockwise and counterclockwise directions
- Battery saving auto-shutoff after two minutes
- COMPUTORQ 3 remembers last unit and torque setting selected
- Audible tone sounds when set torque value is reached, if the set torque value is exceeded, an alarm tone will sound
- 3 color LED light bar
YELLOW LED indicates approaching desired torque setting
GREEN LED indicates desired torque value is reached
RED LED indicates fastener was overtorqued, loosen and retighten
- When desired torque value is reached, display will hold value and flash for ten seconds
- COMPUTORQ 3 will operate in any of four torque units, foot pounds (ft. lbs.), inch pounds (in. lbs.), newton meter (Nm) or kilogram centimeter (kg. cm.)
- **ACCURACY:**
± 2% CW of readings from 20% to 100% of full scale
± 3% CCW of readings from 20% to 100% of full scale
- N.I.S.T. traceable certificate of calibration included
Meets or exceeds ASME B107.28 - 2005

Stock No.	Square Drive (inches)	Range (Ft. Lb.)	Range (In. Lb.)	Range (Nm)	Range (Kg. Cm.)	Length (mm)	Weight (g)	Order No.
BP2401C13	1/4	2.0 - 20.0	24 - 240	2.71 - 27.10	27.6 - 276	381	910	205001
BP1002CF3	3/8	10.0 - 100.0	120 - 1200	13.6 - 135.6	138 - 1382	432	1,000	205002
BP2503CF3	1/2	25 - 250	300 - 3000	33.8 - 338	345 - 3456	686	1,590	205003

CompuTorq 3 Digital Torque Wrench



- Uses CR123 replaceable batteries
- Audible tone indication

Digital Torque Tester



- Integral Transducer and sturdy housing allow mounting in virtually any position
- Integral Transducer: Full bridge strain gage, 350 ohm, 1500uE, 3mV/V F.S, 3.75 excitation
- Units of Torque: Nm, kgcm, ft.lb., in.-oz.
- Audible (tone)
- Torque Accuracy: ±0.5% ±1 count CW and CCW from 10 to 100% of full scale at 25° C
- LCD Touch Screen: 4.7 in. color graphics display
- Screen resolution: 480 X 272 pixels
- Display Accuracy: 4 digits, 9999 cycle counts
- Six "AA" Alkaline cells for battery power included
- Track, Peak and First Peak modes of operation
- Operating Temperature: 40 to 110° F (5 to 42° C)
- Storage Temperature: 0 to 122° F (-20 to 50° C)
- Humidity up to 85% non-condensing
- ISO-6789-2003 and ASME B107-28-2005 standards compliant
- Certificate of N.I.S.T. traceability from 10% to 100% of full scale
- Includes storage case, AC adapter and USB cable
- 110 - 220v
- Dates & times, serial numbers, required accuracy vs actual readings, percentage error & users of torque wrenches tested are stored

Stock No.	Square Drive (inches)	English Range	Range (Nm)	Order No.
BP1001-O-DTT	1/4	10 - 100 in.oz.	0.07 - 0.706	206001
BP501-I-DTT	1/4	5 - 50 in.lb.	0.56 - 5.65	206002
BP2502-I-DTT	3/8	25 - 250 in.lb.	2.82 - 28.25	206003
BP2503-F-DTT	1/2	25 - 250 ft.lb.	33.90 - 338.9	206004
BP6004-F-DTT	3/4	60 - 600 ft.lb.	81.35 - 813.5	206005
BP10002-I-DTT	3/8	100 - 1000 in.lb.	11.3 - 113	206006

Digital Torque Tester



- Remembers last 9999 cycle counts
- Audible tone signals



Power Tools



In making our power tools, we observed the fact that not only has it got to be durable and perform well, it is not much good if you are fighting excess weight, vibration and noise. Basing on this, we come up with a whole range of power tools that embrace these qualities and more.

Air

Our impact wrench feature unique twin hammer impact mechanism to deliver more power per blow. Having more vanes in the rotor also helps in delivering more power as well as a smoother power transfer to the impact hammers. The aluminium alloy housing maintains tool toughness and durability. All these are achieved while keeping weight and vibration to a minimum.

Cordless

Heavy duty components combined with strong and lightweight bodies give our cordless tools more power while being light. Ergonomic grips coupled with vibration absorbing features offer a smoother, more comfortable operation. And long lasting high capacity batteries allow you to work longer with less disruption. The result is a compact power tool that is lightweight, balanced and delivers performance you need.

Air Tools	72
Cordless Tools	87
Impact Sockets	88
Accessories	95

1" Impact Wrench, Heavy Duty

Packing: 1 Order NO.: 701001

AT1300A

AT1300AL (6" long Anvil)

Order NO.: 701002

Drive Size (inches)	Max. Torque (N-m)	Free Speed RPM	Blows per Minute
1	4,068	4,000	505
Air Consumption, Free Speed (L/MIN)	Air Inlet Thread Size	Recommended Hose Size (inches)	Vibration Level (m/s ²)
150	1/2"-14 NPT	1/2	4.4
Sound Level dBa Pressure	Length (mm)	Weight (kg)	Vinyl Boot (optional)
103	533	11.6	—

- Fast, 4,000 RPM free speed-strong 3,000 ft. lb. maximum torque output
- Workhorse performance for use on trucks, buses and heavy equipment
- Steel nose for rugged, demanding applications
- Pin clutch style impact mechanism for fast startup and high torque requirements

3/4" Impact Wrench

Packing: 1 Order NO.: 701003

AT760

AT760L (6" long Anvil)

Order NO.: 701004

Drive Size (inches)	Max. Torque (N-m)	Free Speed RPM	Blows per Minute
3/4	1,492	4,000	905
Air Consumption, Free Speed (L/MIN)	Air Inlet Thread Size	Recommended Hose Size (inches)	Vibration Level (m/s ²)
159	3/8"-18 NPT	3/8	<4.3
Sound Level dBa Pressure	Length (mm)	Weight (kg)	Vinyl Boot (optional)
114.4	241	3.8	AT760BOOT

- Lightweight composite housing with aluminum nose
- 3 position thumb operated forward/reverse lever
- Bottom handle exhaust
- Twin hammer mechanism

1/2" Impact Wrench

Packing: 1 Order NO.: 701005

AT123B

AT123BL (2" Long Anvil)

Order NO.: 701006

Drive Size (inches)	Max. Torque (N-m)	Free Speed RPM	Blows per Minute
1/2	576	9,000	1,000
Air Consumption, Free Speed (L/MIN)	Air Inlet Thread Size	Recommended Hose Size (inches)	Vibration Level (m/s ²)
79	1/4"-18 NPT	3/8	13
Sound Level dBa Pressure	Length (mm)	Weight (kg)	Vinyl Boot (optional)
108	185	2.6	AT123-45

- Twin hammer impact mechanism provides harder hitting blows
- Steel nose case with lightweight aluminum housing
- Pressure feed grease lubrication
- Convenient slide bar forward/reverse

1/2" Composite Impact Wrench

Packing: 1 Order NO.: 701064

AT570

New

Drive Size (inches)	Max. Torque (N-m)	Free Speed RPM	Blows per Minute
1/2	570 ft lbs	6,900(F), 7,000(R)	1,050
Air Consumption, Free Speed (L/MIN)	Air Inlet Thread Size	Recommended Hose Size (inches)	Vibration Level (m/s ²)
5.0 cfm(F), 5.3 cfm (rev.)	1/4"-18 NPT	3/8	6.08
Sound Level dBa Pressure	Length (mm)	Weight (kg)	Vinyl Boot (optional)
95	184	1.87	AT570BOOT

- Shot Peen Anvils for improved durability
- Reverse Bias motor provides additional breakaway torque
- 3 position regulator to control power
- One handed forward/reverse lever for user convenience
- Composite housing with aluminum nose combine to deliver a durable, lightweight and balanced unit.
- Twin hammer impact mechanism delivers hard hitting blows to quickly remove stubborn fasteners

1/2" Impact Wrench, Soft Handle

Packing: 1 Order NO.: 701007

AT555B

Drive Size (inches)	Max. Torque (N-m)	Free Speed RPM	Blows per Minute
1/2	644(F), 745(R)	6,800 (F), 7,500 (R)	1,000
Air Consumption, Free Speed (L/MIN)	Air Inlet Thread Size	Recommended Hose Size (inches)	Vibration Level (m/s ²)
62	1/4"-18 NPT	3/8	3.75
Sound Level dBa Pressure	Length (mm)	Weight (kg)	Vinyl Boot (optional)
100	198	2.6	AT555BOOT

- Powerful twin hammer clutch
- Reverse bias air motor provides greater power in reverse when extra breakaway torque is needed
- Built-in power regulator
- Molded ergonomic handle grip
- Quiet Muffler
- Through-handle exhaust

1/2" Impact Wrench, Composite Rear Housing

Packing: 1 Order NO.: 701009

ATC500

Drive Size (inches)	Max. Torque (N-m)	Free Speed RPM	Blows per Minute
1/2	712	10,500	1,250
Air Consumption, Free Speed (L/MIN)	Air Inlet Thread Size	Recommended Hose Size (inches)	Vibration Level (m/s ²)
99	1/4"-18 NPT	3/8	<2.5
Sound Level dBa Pressure	Length (mm)	Weight (kg)	Vinyl Boot (optional)
95.5	198	2.3	IMC500BOOT

- Aluminum front housing and composite rear housing contribute to an extremely durable, lightweight, balanced unit
- Ribbed, textured handle for maximum comfort and control
- Four position power regulator for greater job versatility
- Twin hammer impact mechanism for longer life and greater power

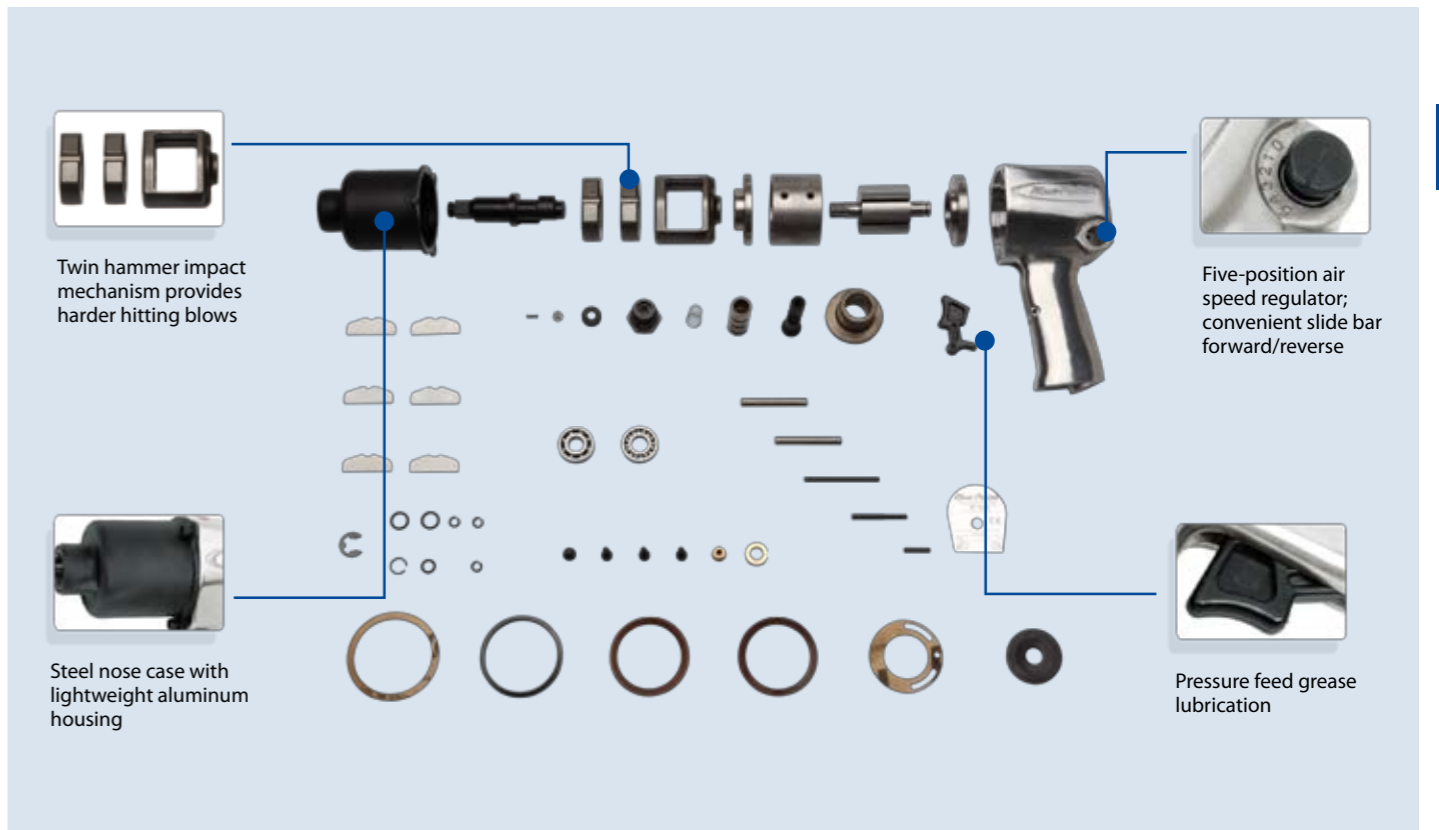
Impact Wrench

3/8" Impact Wrench

Packing: 1 Order NO.: 701010

AT380

Drive Size (inches)	Max. Torque (N-m)	Free Speed RPM	Blows per Minute
3/8	244	11,000	1,400
Air Consumption, Free Speed (L/MIN)	Air Inlet Thread Size	Recommended Hose Size (inches)	Vibration Level (m/s ²)
76	1/4"-18 NPT	3/8	3.5
Sound Level dBa Pressure	Length (mm)	Weight (kg)	Vinyl Boot (optional)
105	160	1.2	YA877A

- Twin hammer impact mechanism provides 180 ft. lb. of torque output
- Ideal tool for transmission and engine work
- Variable speed trigger for superior control
- Built in 5 position air regulator

3/8" Impact Wrench, Composite

Packing: 1 Order NO.: 701065

AT370

Drive Size (inches)	Max. Torque (N-m)	Free Speed RPM	Blows per Minute
3/8	320 ft lbs	10,000(F), 11,000(R)	1,050
Air Consumption, Free Speed (L/MIN)	Air Inlet Thread Size	Recommended Hose Size (inches)	Vibration Level (m/s ²)
4.4 cfm(F), 4.7 cfm (R)	1/4"-18 NPT	3/8	3.25
Sound Level dBa Pressure	Length (mm)	Weight (kg)	Vinyl Boot (optional)
92	160	1.19	AT370BOOT

- Shot Peen Anvils for improved durability
- Reverse Bias motor provides additional breakaway torque
- 3 position regulator to control power
- One handed forward/reverse lever for user convenience
- Composite housing with aluminum nose combine to deliver a durable, lightweight and balanced unit.
- Twin hammer impact mechanism delivers hard hitting blows to quickly remove stubborn fasteners

1/4" Impact Wrench, Mini

Packing: 1 Order NO.: 701014

AT235MCA

Drive Size (inches)	Max. Torque (N-m)	Free Speed RPM	Blows per Minute
1/4	34	13,000	2,900
Air Consumption, Free Speed (L/MIN)	Air Inlet Thread Size	Recommended Hose Size (inches)	Vibration Level (m/s ²)
47	1/4"-18 NPT	3/8	<2.5
Sound Level dBa Pressure	Length (mm)	Weight (kg)	Vinyl Boot (optional)
95.1	158	64	—

- Composite housing contributes to an extremely durable, lightweight unit with new molded comfort grip
- Composite housing is not cold to the touch
- Forward/Reverse mechanism easily operated with one-finger
- Large, variable speed trigger for control
- Exhaust is from the handle bottom, keeping exhaust away from work area and user

1/2" Ratchet

Packing: 1 Order NO.: 701015

AT705B

Drive Size (inches)	Torque Range (N-m)	Free Speed RPM	Air Consumption, Free Speed (L/MIN)
1/2	6 - 68	150	85
Air Inlet Thread Size	Recommended Hose Size (inches)	Vibration Level (m/s ²)	Sound Level dBa Pressure
1/4"-18 NPT	3/8	8.7	89
Length (mm)	Weight (kg)	Vinyl Boot (included)	
273	1.14	AT700E49A	

- 1/2" drive ratchet in a 3/8" drive body
- Delivers 50 ft. lb. of maximum torque
- Ball bearing mounted motor for longer tool life

3/8" Impact Wrench, Single Hammer

Packing: 1 Order NO.: 701011

AT321

Drive Size (inches)	Max. Torque (N-m)	Free Speed RPM	Blows per Minute
3/8	237	11,000	1,500
Air Consumption, Free Speed (L/MIN)	Air Inlet Thread Size	Recommended Hose Size (inches)	Vibration Level (m/s ²)
108	1/4"-18 NPT	3/8	9.8
Sound Level dBa Pressure	Length (mm)	Weight (kg)	Vinyl Boot (optional)
109	155	1.3	AT321-44

- Single hammer impact mechanism
- Steel nose case with lightweight aluminum housing
- Convenient slide bar forward/reverse

3/8" Impact Wrench, Compact

Packing: 1 Order NO.: 701013

AT351

Drive Size (inches)	Max. Torque (N-m)	Free Speed RPM	Blows per Minute
3/8	237	9,700	1,200
Air Consumption, Free Speed (L/MIN)	Air Inlet Thread Size	Recommended Hose Size (inches)	Vibration Level (m/s ²)
71	1/4"-18 NPT	3/8	3.09
Sound Level dBa Pressure	Length (mm)	Weight (kg)	Vinyl Boot (optional)
109.2	194	1.2	—

- Built-in air inlet swivel
- 8 position power regulator
- Rotary action air motor is ball bearing mounted for balance, speed and power
- Ideal tool for small engine repair and bench work

3/8" Ratchet

Packing: 1 Order NO.: 701016

AT704

Drive Size (inches)	Torque Range (N-m)	Free Speed RPM	Air Consumption, Free Speed (L/MIN)
3/8	6 - 75	200	111
Air Inlet Thread Size	Recommended Hose Size (inches)	Vibration Level (m/s ²)	Sound Level dBa Pressure
1/4"-18 NPT	3/8	<3.9	104
Length (mm)	Weight (kg)	Vinyl Boot (included)	
266	1.5	—	

- Lightweight aluminum housing
- Rugged ball bearing mounted air motor and precision planetary gear system
- Easy to use variable speed throttle plus adjustable air regulator

3/8" Ratchet, High Torque

Packing: 1 Order NO.: 701018

AT702

Drive Size (inches)	Torque Range (N-m)	Free Speed RPM	Air Consumption, Free Speed (L/MIN)
3/8	6 - 81	200	85
Air Inlet Thread Size	Recommended Hose Size (inches)	Vibration Level (m/s ²)	Sound Level dBa Pressure
1/4"-18 NPT	3/8	12.6	95
Length (mm)	Weight (kg)	Vinyl Boot (included)	
265	1.1	AT700E49A	

- Flywheel mechanism
- Rugged ball bearing mounted air motor coupled with precision planetary gear system
- Easy to use variable speed throttle and adjustable air regulator

3/8" Ratchet

Packing: 1 Order NO.: 701019

AT738

Drive Size (inches)	Torque Range (N-m)	Free Speed RPM	Air Consumption, Free Speed (L/MIN)
3/8	0 - 81	300	113
Air Inlet Thread Size	Recommended Hose Size (inches)	Vibration Level (m/s ²)	Sound Level dBa Pressure
1/4"-18 NPT	3/8	5.9	102
Length (mm)	Weight (kg)	Vinyl Boot (included)	
285	1.3	AT738BOOT	

- Reactionless mechanism absorbs kickback when running fasteners tight
- High RPM removes fasteners quickly
- Adjustable air regulator
- Ideal tool for spark plugs, water pumps, shocks and muffler clamps

3/8" Ratchet

Packing: 1 Order NO.: 701017

AT700F

Drive Size (inches)	Torque Range (N-m)	Free Speed RPM	Air Consumption, Free Speed (L/MIN)
3/8	6 - 61	150	85
Air Inlet Thread Size	Recommended Hose Size (inches)	Vibration Level (m/s ²)	Sound Level dBa Pressure
1/4"-18 NPT	3/8	8.7	89
Length (mm)	Weight (kg)	Vinyl Boot (included)	
257	1.6	AT700E49A	

- Lightweight aluminum housing
- Rugged ball bearing mounted air motor and precision planetary gear system
- Easy to use variable speed throttle plus adjustable air regulator

1/4" Ratchet, Mini

Packing: 1 Order NO.: 701022

AT204

Drive Size (inches)	Torque Range (N-m)	Free Speed RPM	Air Consumption, Free Speed (L/MIN)
1/4	6 - 30	275	68
Air Inlet Thread Size	Recommended Hose Size (inches)	Vibration Level (m/s ²)	Sound Level dBa Pressure
1/4"-18 NPT	3/8	<1.7	91
Length (mm)	Weight (kg)	Vinyl Boot (included)	
127	66	—	

- Ideal for working in tight quarters
- Head clearance is less than 3/4"
- Includes variable speed trigger, adjustable air regulator and 5' nylon braided whip hose for maneuverability and control
- Polished aluminum housing provides strength and durability

Spotweld Drill

Packing: 1 Order NO.: 701023

AT184

Chuck Size (inches)	Rated Power (kW)	Torque Range (N-m)	Free Speed RPM
5/16	—	—	1,800
Air Consumption, Free Speed (L/MIN)	Air Inlet Thread Size	Recommended Hose Size (inches)	Vibration Level (m/s ²)
238	1/4"-18 NPT	3/8	<1.0
Sound Level dBa Pressure	Length (mm)	Weight (kg)	Spotweld Drill Bit (8mm) (included)
84	201	1.4	AT183-50
Spotweld Drill Bit (6.5mm) (optional)	Support Arm 5.5 (optional)	Spotweld Drill Bit (10mm) (optional)	
AT183-43	AT184-26A	AT183-51	

- Twist depth control collar allows precise setting of drilling depth up to 1/4"
- Two speed trigger for low or high speeds
- Pistol grip design
- Includes one 5/16" (8 mm) drill bit and removeable clamp arm

1/4" Ratchet

Packing: 1 Order NO.: 701020

AT203

Drive Size (inches)	Torque Range (N-m)	Free Speed RPM	Air Consumption, Free Speed (L/MIN)
1/4	6 - 34	285	88
Air Inlet Thread Size	Recommended Hose Size (inches)	Vibration Level (m/s ²)	Sound Level dBa Pressure
1/4"-18 NPT	3/8	<4.4	100
Length (mm)	Weight (kg)	Vinyl Boot (included)	
188	57	—	

- Lightweight aluminum housing
- Rugged ball bearing mounted air motor and precision planetary gear system
- Easy to use variable speed throttle plus adjustable air regulator

1/4" Ratchet

Packing: 1 Order NO.: 701021

AT200D

Drive Size (inches)	Torque Range (N-m)	Free Speed RPM	Air Consumption, Free Speed (L/MIN)
1/4	6 - 27	150	40
Air Inlet Thread Size	Recommended Hose Size (inches)	Vibration Level (m/s ²)	Sound Level dBa Pressure
1/4"-18 NPT	3/8	3.3	85
Length (mm)	Weight (kg)	Vinyl Boot (included)	
222	50	AT200D22A	

- Lightweight aluminum housing
- Rugged ball bearing mounted air motor and precision planetary gear system

1/2" Drill

Packing: 1 Order NO.: 701024

AT5000

Chuck Size (inches)	Rated Power (kW)	Torque Range (N-m)	Free Speed RPM
1/2	0.33	0 - 14	490
Spindle Thread (inches)	Air Consumption, Free Speed (L/MIN)	Air Inlet Thread Size	Recommended Hose Size (inches)
1/2"-20 UNF	108	1/4"-18 NPT	3/8
Vibration Level (m/s ²)	Sound Level dBa Pressure	Length (mm)	Weight (kg)
<2.5	82	229	1.7
Auxiliary Handle	Vinyl Boot (optional)		
PDAH1A	AT5000BOOT		

- One hand forward/reverse operation
- Three planet gear design for durability and balance
- Bottom handle diffused exhaust
- Comfort grip handle
- Keyed chuck easily handles 120 in. lbs. of torque
- Chuck key stores in handle

3/8" Drill

Packing: 1 Order NO.: 701025

AT3000

Chuck Size (inches)	Rated Power (kW)	Torque Range (N-m)	Free Speed RPM
3/8	0.15	0 - 4	2,000
Spindle Thread (inches)	Air Consumption, Free Speed (L/MIN)	Air Inlet Thread Size	Recommended Hose Size (inches)
3/8"-24 UNF	99	1/4"-18 NPT	3/8
Vibration Level (m/s ²)	Sound Level dBa Pressure	Length (mm)	Weight (kg)
<2.5	105	194	1.4
Auxiliary Handle	Vinyl Boot (optional)		
—	AT3000BOOT		

- One hand forward/reverse operation
- Three planet gear design for durability and balance
- Bottom handle diffused exhaust
- Comfort grip handle
- Keyless chuck saves time when changing bits

3/8" Drill, Angle

Packing: 1 Order NO.: 701026

AT811



Chuck Size (inches)	Rated Power (kW)	Torque Range (N-m)	Free Speed RPM
3/8	0.19	0 - 6	1,320
Spindle Thread (inches)	Air Consumption, Free Speed (L/MIN)	Air Inlet Thread Size	Recommended Hose Size (inches)
3/8-24 UNF	95	1/4"-18 NPT	3/8
Vibration Level (m/s ²)	Sound Level dBa Pressure	Length (mm)	Weight (kg)
<0.8	110	208	1.1

- Rugged, reversible right angle drill gets in tight spots comfortably
- Convenient one hand push button forward/reverse
- Rear exhaust keeps air away from the work area
- Built in chuck key holder keeps the key at hand for quick bit changes
- Paddle style trigger for greater comfort
- Ball bearing construction for longer tool life
- Lightweight helps avoid fatigue during prolonged use
- Bottom handle diffuse exhaust

1/4" Drill, Micro

Packing: 1 Order NO.: 701027

AT801MCA



Chuck Size (inches)	Rated Power (kW)	Torque Range (N-m)	Free Speed RPM
1/4	0.19	0 - 2	1,800
Spindle Thread (inches)	Air Consumption, Free Speed (L/MIN)	Air Inlet Thread Size	Recommended Hose Size (inches)
3/8-24 UNF	266	1/4"-18 NPT	3/8
Vibration Level (m/s ²)	Sound Level dBa Pressure	Length (mm)	Weight (kg)
<2.5	96.4	183	0.68

- Composite housing with new molded comfort grip is more comfortable for the user while providing less user fatigue
- Small size, light weight and a powerful motor make this tool ideal for working in confined areas
- Durable single piece polymer composite housing stands up to rugged use, resists most shop chemicals and helps insulate against the cold generated by an air tool
- Variable speed trigger

1/4" Die Grinder, Right Angle Mini

Packing: 1 Order NO.: 701030

AT118



Collet Size (inches)	Rated Power (kW)	Free Speed RPM	Air Consumption, Free Speed (L/MIN)
1/4	0.15	20,000	59
Air Inlet Thread Size	Recommended Hose Size (inches)	Vibration Level (m/s ²)	Sound Level dBa Pressure
1/4"-18 NPT	3/8	2.5	104
Length (mm)	Weight (kg)		
140	0.50		

- Clean dies, rotors, backing plates and brake pad mounts
- Remove gasket material
- Grind dies and valve seats
- Dress welds and enlarge holes
- Compact mini-design with 90° angled head for easy access
- Ergonomic handle grip increases comfort and control
- Safety lever throttle
- Built-in speed regulator
- Brass bearing cap and hose adaptor

1/4" Die Grinder, Standard

Packing: 1 Order NO.: 701031

AT105



Collet Size (inches)	Rated Power (kW)	Free Speed RPM	Air Consumption, Free Speed (L/MIN)
1/4	0.15	22,000	113
Air Inlet Thread Size	Recommended Hose Size (inches)	Vibration Level (m/s ²)	Sound Level dBa Pressure
1/4"-18 NPT	3/8	<2.5	102
Length (mm)	Weight (kg)		
165	0.61		

- Aluminum housing for long lasting durability
- Intended for most standard deburring operations
- High quality bearings improve productivity with less repair
- Rear exhaust directs air away from work area

Hammer

Packing: 1 Order NO.: 701028

AT2050



Bore Diameter (inches)	Blows per Minute	Piston Stroke (inches)	Shank Opening (mm)	
3/4	3,400	2.75	10.1	
Air Consumption, Free Speed (L/MIN)	Air Inlet Thread Size	Recommended Hose Size (inches)	Vibration Level (m/s ²)	
71	1/4"-18 NPT	3/16	3.0	
Vibration Level	Sound Level dBa Pressure	Length (mm)	Weight (kg)	Vinyl Boot (optional)
3 m/s ²	99	187	2.1	AT2050BOOT

- Intended for heavy duty applications such as cutting large bolts and rivets, separating ball joints, cutting heavy gauge sheet metal and driving bushings
- Comfort grip handle
- Includes quick change retainer

1/4" Die Grinder, Standard

Packing: 1 Order NO.: 701029

AT115



Collet Size (inches)	Rated Power (kW)	Free Speed RPM	Air Consumption, Free Speed (L/MIN)
1/4	0.15	22,000	113
Air Inlet Thread Size	Recommended Hose Size (inches)	Vibration Level (m/s ²)	Sound Level dBa Pressure
1/4"-18 NPT	3/8	<2.5	102
Length (mm)	Weight (kg)		
165	0.61		

- Intended for most standard deburring operations
- Ergonomic handle grip increases comfort and control
- Safety lever throttle
- Built-in speed regulator
- Brass bearing cap and hose adaptor
- Rear diffused exhaust

1/4" Die Grinder, Right Angle Mini

Packing: 1 Order NO.: 701032

AT109



Collet Size (inches)	Rated Power (kW)	Free Speed RPM	Air Consumption, Free Speed (L/MIN)
1/4	0.15	20,000	59
Air Inlet Thread Size	Recommended Hose Size (inches)	Vibration Level (m/s ²)	Sound Level dBa Pressure
1/4"-18 NPT	3/8	2.5	104
Length (mm)	Weight (kg)		
140	0.50		

- Aluminum housing for long lasting durability
- Compact mini design with 90° head for easy access
- High quality bearings improve productivity with less repair
- Rear exhaust directs air away from work area

Die Grinder Kit

Packing: 1 Order NO.: 701033

AT109DGK



Rated Power (kW)	Free Speed RPM	Air Consumption, Free Speed (L/MIN)	Air Inlet Thread Size	
0.15	20,000	59	1/4"-18 NPT	
Recommended Hose Size (inches)	Vibration Level (m/s ²)	Sound Level dBa Pressure	Length (mm)	Weight (kg)
3/8	2.5	104	140	0.50

- Aluminum housing
- Compact mini design
- Rear exhaust
 - Includes: AT109 mini angle die grinder plus 2" (50.8mm) ROLOC® pad (1 ea.), 2" (50.8mm) coarse discs (2 ea.), 2" (50.8mm) medium discs (2 ea.), 2" (50.8mm) 24 grit discs (2 ea.), 2" (50.8mm) 36 grit discs (2 ea.), 2" (50.8mm) crud discs (2 ea.), 3" (76.2mm) ROLOC® pad (1 ea.), 3" (76.2mm) 50 grit discs (2 ea.), 3" (76.2mm) 120 grit discs (2 ea.), 3" (76.2mm) crud discs (2 ea.), 1/4" shank adaptor (1 ea.) and spanner wrenches (2 ea.) in storage case

1/4" Die Grinder, Mini

Packing: 1 Order NO.: 701034

AT119



Recommended Air Pressure, psig (kPa)	Air Consumption, Free Speed (L/MIN)	Free Speed RPM
620	85	20,000
Sound Level, free speed, dBa	Collet Size (inches)	Overall Length, inches (mm)
100	1/4	165

- 115 degree offset head provides a more ergonomic grinding position
- Thread-on style disc provides a more compact head
- One 2" quick-change disc included so tool is ready for your abrasive pad

Die Grinder Kit

Packing: 1 Order NO.: 701035

AT119DGK



Rated Power (kW)	Free Speed RPM	Air Consumption, Free Speed (L/MIN)	Air Inlet Thread Size	
33	2,000	59	1/4"-18 NPT	
Recommended Hose Size (inches)	Vibration Level (m/s ²)	Sound Level dBa Pressure	Length (mm)	Weight (kg)
3/8	<6.92	100	173	50

- Thread-on style disc provides a more compact head than collet style units
 - 115° offset head provides a more ergonomic grinding position
 - Ideal for cleaning dies, rotors, backing plates and gasket material
- Includes: 115° Mini Offset Angle Die Grinder plus: 2" (50.8mm) ROLOC® pad (1 ea.), 2" (50.8mm) coarse discs (2 ea.), 2" (50.8mm) medium discs (2 ea.), 2" (50.8mm) 24 grit discs (2 ea.), 2" (50.8mm) 36 grit discs (2 ea.), 2" (50.8mm) crud discs (2 ea.), 3" (76.2mm) ROLOC® pad (1 ea.), 3" (76.2mm) coarse discs (2 ea.), 3" (76.2mm) medium discs (2 ea.), 3" (76.2mm) 50 grit discs (2 ea.), 3" (76.2mm) 120 grit discs (2 ea.), 3" (76.2mm) crud discs (2 ea.), and spanner wrench (1 ea.) in storage case

Die Grinder, Pencil

Packing: 1 Order NO.: 701036

AT1070A



Collet Size (inches)	Rated Power (kW)	Free Speed RPM	Air Consumption, Free Speed (L/MIN)
1/8	—	75,000	28
Air Inlet Thread Size	Recommended Hose Size (inches)	Vibration Level (m/s ²)	Sound Level dBa Pressure
1/4"-18 NPT	3/8	2.0	72
Length (mm)	Weight (kg)		
135	0.25		

- Twist-action variable speed control
- 5' (1.5 M) long protected air hose
- Used with 1/8" shank grinding accessories higher than 5,4000 RPM
- Ideal for tight spaces and easy cleaning of dies, rotors and brake pads

Die Grinder, Pencil, Right Angle

Packing: 1 Order NO.: 701037

AT1070RA



Collet Size (inches)	Rated Power (kW)	Free Speed RPM	Air Consumption, Free Speed (L/MIN)
1/8	—	75,000	28
Air Inlet Thread Size	Recommended Hose Size (inches)	Vibration Level (m/s ²)	Sound Level dBa Pressure
1/4"-18 NPT	3/8	2.0	72
Length (mm)	Weight (kg)		
150	0.21		

- Right angle lightweight pencil die grinder is ideal for getting in tight spaces
- Use for easy cleaning of dies, rotors, backing plates, brake pads, mounts plus many other applications
- Must be used with 1/8" shank grinding accessories rated higher than 70,000 RPM

4" Cut Off Tool, Reversible

Packing: 1 Order NO.: 701038

AT154R



Wheel Size (inches)	Rated Power (kW)	Free Speed RPM	Air Consumption, Free Speed (L/MIN)	
4	0.67	16,000	102	
Air Inlet Thread Size	Recommended Hose Size (inches)	Vibration Level (m/s ²)	Sound Level dBa Pressure	
1/4"-18 NPT	3/8	<.6	104	
Length (mm)	Weight (kg)	3" Cutter Wheels (36 grit) (optional)	3" Cutter Wheels (54 grit) (optional)	4" Cutter Wheels
376	1.4	—	—	AT154RWHLMP

- Reversible 4" cut-off tool is ideal for use in body shops and other general automotive applications
- Recommended for cutting mufflers, hose clamps, bolts and sheet metal
- 14.8" overall length provides easier access to hard to reach work areas
- Reverse mode controls the direction of sparks for safety
- Side handle offers additional tool control
- Rear diffused exhaust
- Comfort grip handle

3" Cut Off Tool, Reversible

Packing: 1 Order NO.: 701039

AT157R



Wheel Size (inches)	Rated Power (kW)	Free Speed RPM	Air Consumption, Free Speed (L/MIN)
3	0.33	20,000	99
Air Inlet Thread Size	Recommended Hose Size (inches)	Vibration Level (m/s ²)	Sound Level dBa Pressure
1/4"-18 NPT	3/8	<3.8	100
Length (mm)	Weight (kg)	3" Cutter Wheels (36 grit) (optional)	3" Cutter Wheels (54 grit) (optional)
185	0.86	AT150-20A	AT150-29A

- Reversible 3" cut-off tool is ideal for use in body shops and other general automotive applications
- Recommended for cutting mufflers, hose clamps, bolts and sheet metal
- Spark direction control
- Safety throttle lever
- Rear diffused exhaust
- Comfort grip handle
- Uses wheels only rated above 18,000 RPM

4 1/2" Grinder, Compact

Packing: 1 Order NO.: 701041

AT415B



Wheel Size (inches)	Rated Power (kW)	Free Speed RPM	Air Consumption, Free Speed (L/MIN)
4 1/2	0.64	12,000	91
Air Inlet Thread Size	Recommended Hose Size (inches)	Vibration Level (m/s ²)	Sound Level dBa Pressure
1/4"-18 NPT	3/8	5.1	87
Length (mm)	Weight (kg)	Grinding Disc	
254	1.9	AT415A51	

- 4 1/2" Compact grinder
- Includes (1) 4 1/2" diameter x 3/16" thick grinding disc

2" Grinder, Angle

Packing: 1 Order NO.: 701042

AT215



Wheel Size (inches)	Rated Power (kW)	Free Speed RPM	Air Consumption, Free Speed (L/MIN)
2	0.37	15,000	85
Air Inlet Thread Size	Recommended Hose Size (inches)	Vibration Level (m/s ²)	Sound Level dBa Pressure
1/4"-18 NPT	3/8	<2.86	73
Length (mm)	Weight (kg)	Grinding Disc (optional)	
188	0.82	AT215GWSET	

- Ideal for body shops, automobile, truck repair and confined areas
- Grease fitting in head-enables gears to be greased for longer tool life
- Includes 6-2" wheels-tool is ready for use providing convenience
- Moveable guard, up to 50° in either direction-fitting various applications
- Built in speed regulator-allows user to set desired speed
- Rear exhaust with rotating deflector
- Comfort grip housing-insulate from cold and vibration for less user fatigue
- Safety lever throttle-prevents accidental start ups for increased safety

Reciprocating Saw

Packing: 1 Order NO.: 701043

AT192A

Free Speed RPM	Air Consumption, Free Speed (L/MIN)	Air Inlet Thread Size	Recommended Hose Size (inches)
11,000	28	1/4"-18 NPT	3/8
Vibration Level (m/s ²)	Sound Level dBa Pressure	Length (mm)	Weight (kg)
10.1	94	235	0.80
Bi-Metal Blade, 18TPI, 3 3/4" long (qty. 5)	Bi-Metal Blade, 32TPI, 3 3/4" long (qty. 5)	Bi-Metal Blade, 24TPI, 3 3/4" long (qty. 5)	
AT190-39A	AT190-41A	AT190-40A	

- Adjustable blade guard to control cutting depth
- Comfort grip housing for greater control
- Performs straight or scroll cuts in metal and plastic
- Safety lever throttle
- Includes three 3 3/4" bi-metal blades: (1) 18TPI coarse, (1) 24TPI medium and (1) 32 TPI fine blade
- Optional blades in 4" lengths are also available

Reciprocating Saw, Micro

Packing: 1 Order NO.: 701044

AT194A

Free Speed RPM	Air Consumption, Free Speed (L/MIN)	Air Inlet Thread Size	Recommended Hose Size (inches)
8,250	20	1/4"-18 NPT	3/8
Vibration Level (m/s ²)	Sound Level dBa Pressure	Length (mm)	Weight (kg)
<6.6	87	175	0.45
Bi-Metal Blade, 18TPI, 3 3/4" long (qty. 5)	Bi-Metal Blade, 32TPI, 3 3/4" long (qty. 5)	Bi-Metal Blade, 24TPI, 3 3/4" long (qty. 5)	
AT190-39A	AT190-41A	AT190-40A	

- Compact size for easy access in tight quarters
- Low vibration level and lightweight yields reduced hand fatigue
- Performs straight or scroll cuts on metal or plastic
- Adjustable blade guard to control cutting depth
- Flexible, guarded hose extension helps prevent damage to finished surface and aids in maneuverability
- Includes three 3 3/4" bi-metal blades: (1) 18TPI coarse, (1) 24TPI medium and (1) 32 TPI fine blade, blade change wrenches and guard adjustment
- Safety trigger prevent accidental start

Nibbler

Packing: 1 Order NO.: 701047

AT180C

Free Speed RPM	Air Consumption, Free Speed (L/MIN)	Air Inlet Thread Size	Recommended Hose Size (inches)
3,500	113	1/4"-18 NPT	3/8
Vibration Level (m/s ²)	Sound Level dBa Pressure	Length (mm)	Weight (kg)
4.3	97	194	0.88

- Cuts mild steel sheet up to 16 gauge (0.62") (1.55mm) thick
- Anvil is adjustable for forward, backward and left or right cutting, enabling the nibbler to make sheet metal cuts of any configuration
- Readily cuts most non-ferrous materials including aluminum, brass, formica, laminates, fiberglass and masonite
- Includes AT180B-10 Standard Punch

8" Sander, Dual Action

Packing: 1 Order NO.: 701048

AT408

Pad Size (inches)	Rated Power (kW)	Free Speed RPM	Spindle Thread (inches)
8	37	850	5/16-24
Air Consumption, Free Speed (L/MIN)	Air Inlet Thread Size	Recommended Hose Size (inches)	Vibration Level (m/s ²)
142	1/4"-18 NPT	3/8	3.7
Sound Level dBa Pressure	Length (mm)	Weight (kg)	Standard Pad
87	281	2.18	AT408-2

- Comfort handle helps reduce fatigue
- Rear diffused exhaust
- Built in adjustable speed regulator
- Variable speed control
- Removable brass filter screens out debris

Dual Punch Tool

Packing: 1 Order NO.: 701045

AT185

Free Speed RPM	Air Consumption, Free Speed (L/MIN)	Air Inlet Thread Size	Recommended Hose Size (inches)
—	320	1/4"-18 NPT	3/8
Vibration Level (m/s ²)	Sound Level dBa Pressure	Length (mm)	Weight (kg)
<2.5	48.6	235	1.2

- Paddle style trigger for maximum control
- Handle exhaust directed away from operator
- Ball bearing mounted rotary air motor for long service
- Built-in speed regulator provides torque control
- Removable brass filter screens out dirt and debris
- Use to make 3/16" and 5/16" punches in light sheet metal
- Head swivels 360° for maximum versatility

Powered Shears

Packing: 1 Order NO.: 701046

AT195

Free Speed RPM	Air Consumption, Free Speed (L/MIN)	Air Inlet Thread Size	Recommended Hose Size (inches)
—	113	1/4"-18 NPT	3/8
Vibration Level (m/s ²)	Sound Level dBa Pressure	Length (mm)	Weight (kg)
<2.5	99.6	254	1.3

- Trims, outlines and shears
- Replaceable brass filter screen
- Built in speed regulator provide

6" Sander, Dual Action

Packing: 1 Order NO.: 701049

AT411A

Pad Size (inches)	Rated Power (kW)	Free Speed RPM	Spindle Thread (inches)
6	0.37	10,000	5/16-18
Air Consumption, Free Speed (L/MIN)	Air Inlet Thread Size	Recommended Hose Size (inches)	Vibration Level (m/s ²)
142	1/4"-18 NPT	3/8	3.7
Sound Level dBa Pressure	Length (mm)	Weight (kg)	Standard Pad
79	203	2.14	AT411A-1

- For fine sanding operations and swirl free finishing

5" Sander, Compact, Angle

Packing: 1 Order NO.: 701050

AT465B

Pad Size (inches)	Rated Power (kW)	Free Speed RPM	Spindle Thread (inches)
5	0.59	6,100	5/16-11
Air Consumption, Free Speed (L/MIN)	Air Inlet Thread Size	Recommended Hose Size (inches)	Vibration Level (m/s ²)
136	1/4"-18 NPT	3/8	<2.5
Sound Level dBa Pressure	Length (mm)	Weight (kg)	Standard Pad
84	248	1.32	AT465-20H

- Built-in adjustable speed regulator
- Rear diffused exhaust
- Side mount auxiliary handle
- Safety throttle lever

7" Sander, Heavy Duty, Angle

Packing: 1 Order NO.: 701051

AT450B

Pad Size (inches)	Rated Power (kW)	Free Speed RPM	Spindle Thread (inches)
7	0.74	5,100	5/16-11
Air Consumption, Free Speed (L/MIN)	Air Inlet Thread Size	Recommended Hose Size (inches)	Vibration Level (m/s ²)
136	1/4"-18 NPT	3/8	5.6
Sound Level dBa Pressure	Length (mm)	Weight (kg)	Standard Pad
84	400	2.50	AT450-46H

5" Sander, Heavy Duty, Vertical

Packing: 1 Order NO.: 701052

AT460B

Pad Size (inches)	Rated Power (kW)	Free Speed RPM	Spindle Thread (inches)
7	0.49	4,500	5/16-11
Air Consumption, Free Speed (L/MIN)	Air Inlet Thread Size	Recommended Hose Size (inches)	Vibration Level (m/s ²)
136	1/4"-18 NPT	3/8	<2.5
Sound Level dBa Pressure	Length (mm)	Weight (kg)	Standard Pad
83	185	2.27	AT450-46H

5" Sander

Packing: 1 Order NO.: 701053

AT425R

Pad Size (inches)	Rated Power (kW)	Free Speed RPM	Spindle Thread (inches)
5	0.33	13,000	7/16-20
Air Consumption, Free Speed (L/MIN)	Air Inlet Thread Size	Recommended Hose Size (inches)	Vibration Level (m/s ²)
122	1/4"-18 NPT	3/8	<0.8
Sound Level dBa Pressure	Length (mm)	Weight (kg)	Standard Pad
93	135	1.28	AT425R-24
3" Replacement Pad (opt.)	4" Replacement Pad (opt.)		
AT425R-22	AT425R-23		

- Use in body shops and other general automotive applications
- Includes 3", 4" and 5" backing discs
- One hand reverse
- Comfort grip handle
- Built-in speed regulator
- 1 year limited warranty on tool
- No warranty on consumables
- CE-DE, ES, FR, IT, GB

In Line Sander, Heavy Duty

Packing: 1 Order NO.: 701054

AT475A

Rated Power (kW)	Free Speed RPM	Air Consumption, Free Speed (L/MIN)	Air Inlet Thread Size
—	1,800	65	1/4"-18 NPT
Recommended Hose Size (inches)	Vibration Level (m/s ²)	Sound Level dBa Pressure	Length (mm)
3/8	14.9	87	406
Weight (kg)	Standard Pad		
3.09	AT475A-29		

- 5/8" stroke
- Minimal vibration

Jitterbug Sander

Packing: 1 Order NO.: 701055

AT435A

Rated Power (kW)	Free Speed RPM	Air Consumption, Free Speed (L/MIN)	Air Inlet Thread Size
0.37	8,000	85	1/4"-18 NPT
Recommended Hose Size (inches)	Vibration Level (m/s ²)	Sound Level dBa Pressure	Length (mm)
3/8	4.5	84	171
Weight (kg)	Standard Pad		
2.09	AT435A-48		

- Features top mounted throttle

3" Surface Prep Tool, Micro

Packing: 1 Order NO.: 701056

AT401MCA

Pad Size (inches)	Rated Power (kW)	Free Speed RPM	Spindle Thread (inches)
3	0.19	15,000	1/4"-20
Air Consumption, Free Speed (L/MIN)	Air Inlet Thread Size	Recommended Hose Size (inches)	Vibration Level (m/s ²)
59	1/4"-18 NPT	3/8	<2.5
Sound Level dBa Pressure	Length (mm)	Weight (kg)	
84	119	0.44	

- Small size, light weight and a powerful motor make the AT401MC
- Surface prep tool ideal for removing paint, rust, gasket material, grinding welds or brake rotors in confined areas
- Accepts 2" and 3" ROLOC® pads
- Pads attach/release with just a 1/4 turn
- Durable single piece polymer composite housing on prep tool stands up to rugged use, resists most shop chemicals and helps insulate against the cold generated by an air tool
- Oversize trigger for easy operation
- Variable speed trigger
- Bottom handle diffused exhaust
- Built in speed regulator offers easy one hand operation

3" Sander, Dual Action, Micro

Packing: 1 Order NO.: 701057

AT402MCA

Pad Size (inches)	Rated Power (kW)	Free Speed RPM	Spindle Thread (inches)
3	0.19	15,000	5/16-24
Air Consumption, Free Speed (L/MIN)	Air Inlet Thread Size	Recommended Hose Size (inches)	Vibration Level (m/s ²)
59	1/4"-18 NPT	3/8	<2.5
Sound Level dBa Pressure	Length (mm)	Weight (kg)	
84	133	0.50	

- Use the AT402MC micro sander to deliver fine swirl free results when sanding, feather edging, scuff sanding, sanding primer surfaces, top coating surface preps, scuffing door and rocker panel jams plus other finesse sanding applications
- Durable single piece polymer composite housing on sander stands up to rugged use, resists most shop chemicals and helps insulate against the cold generated by an air tool
- Oversize trigger for easy operation
- Variable speed trigger
- Bottom handle diffused exhaust
- Built-in speed regulator is easily operated with one hand

3" Polisher, Micro

Packing: 1 Order NO.: 701058

AT403MCA

Pad Size (inches)	Rated Power (kW)	Free Speed RPM	Spindle Thread (inches)
3	0.19	6,000	5/16-24
Air Consumption, Free Speed (L/MIN)	Air Inlet Thread Size	Recommended Hose Size (inches)	Vibration Level (m/s ²)
62	1/4"-18 NPT	3/8	<2.5
Sound Level dBa Pressure	Length (mm)	Weight (kg)	
86	143	0.60	

- Small size, light weight and a powerful motor make the AT403MCA micro polisher ideal for polishing motorcycles, bumpers, wheels and more
- Durable single piece polymer composite housing on polisher stands up to rugged use, resists most shop chemicals and helps insulate against the cold generated by an air tool
- Oversize, variable speed trigger for easy operation with a gloved hand
- Bottom handle diffused exhaust
- Built in speed regulator offers easy one hand operation

Sander Kit, Dual Action, Micro

Packing: 1 Order NO.: 701059

AT401MCKA



- Includes:
 - AT401MCA micro surface prep tool
 - (1) 2" ROLOC® pad
 - (1) 3" ROLOC® pad
 - (5) 2" 40 grit pads
 - (5) 3" 80 grit pads in storage case

3" Polisher, Micro

Packing: 1 Order NO.: 701060

AT402MCKA



- Includes:
 - AT402MC micro sander
 - (1) 3" Hook-It® pad
 - (25) 3" 180 grit pads
 - (25) 3" 200 grit pads
 - (10) 3" 320 grit pads
 - (10) 3" 800 grit pads in storage case

Polisher Kit, Micro

Packing: 1 Order NO.: 701061

AT403MCKA



- Includes:
 - AT403MCA micro polisher
 - (1) 3" Hook-It® pad
 - (1) 3" wool pad
 - (1) 3" foam pad in storage case

Polisher, Heavy Duty, Vertical

Packing: 1 Order NO.: 701062

AT460BP



Pad Size (inches)	Rated Power (kW)	Free Speed RPM	Spindle Thread (inches)
7	0.49	4,500	5/8-11
Air Consumption, Free Speed (L/MIN)	Air Inlet Thread Size	Recommended Hose Size (inches)	Vibration Level (m/s ²)
136	1/4"-18 NPT	3/8	<2.5
Sound Level dBA Pressure	Length (mm)	Weight (kg)	Standard Pad Spanner Wrench (opt.)
83	185	2.27	AT450-46H AT450-50

- Removable side handle

Polisher, Heavy Duty, Angle

Packing: 1 Order NO.: 701063

AT450BP



Pad Size (inches)	Rated Power (kW)	Free Speed RPM	Spindle Thread (inches)
7	0.74	5,100	5/8-11
Air Consumption, Free Speed (L/MIN)	Air Inlet Thread Size	Recommended Hose Size (inches)	Vibration Level (m/s ²)
136	1/4"-18 NPT	3/8	<2.5
Sound Level dBA Pressure	Length (mm)	Weight (kg)	Standard Pad Spanner Wrench (opt.)
84	400	2.50	AT450-46H AT450-50

- Removeable side handle

3/8" Impact Wrench

Packing: 1 Order NO.: 702001

ETB14438A



Square Drive (inches)	Blows per Minute (BPM)	Maximum Torque (N-m)	Free Speed (RPM)	Duration of each full charge	
3/8	2400	189	0-2,200	More than 300 tightening cycles	
Motor / Battery Voltage (V)	Length (mm)	Weight (kg)	Battery Pack	Battery Charger	Charge Time (min)
14.4	178	1.9	ETB14419A	ETB14401A	45

- Delivers 140 ft. lbs. max torque in a compact design to provide the user maximum versatility
- Includes two batteries and one charger packed in a blow molded case
- Batteries have a 1.9 Ah that provides a long run time
- Easily replaceable carbon brushes to keep your investment running like new
- Slide-on battery provides better contact and safer operation since battery won't drop
- Perfectly balanced compact shape with surrounding soft-grip handle reduces fatigue
- Space included in the molded case to add the ETB14410A LED light

3/8" Drill, Two Speed

Packing: 1 Order NO.: 702002

ETB14420A



Chuck Cap (inches)	No Load Speed (RPM)	Maximum Torque (N-m)	Motor/Battery Voltage (V)	Charge Time (min)
3/8	0-400/0-1400	30	14.4	45
Battery Pack	Battery Charger	Length (mm)	Weight (kg)	Duration of each full charge
ETB14419A (1.9Ah)	ETB14401A	216	1.9	More than 30 drilling cycles

- Includes cordless drill, 2 batteries and battery charger
- Keyless chuck provides quick replacement of bits to save time
- Two speed switch and variable speed trigger offers maximum control in both forward and reverse
- Clutch cap provides 20 different settings up to 260 inch pounds torque for precision jobs
- White LED illuminates when trigger is depressed for those dim working conditions
- Slide-on battery provides better contact and safer operation since battery won't drop
- Perfectly balanced compact shape with surrounding soft-grip handle reduces fatigue
- Space included in the molded case to add the ETB14410A light

3/8" Drill

Packing: 1 Order NO.: 702004

ETB14430A



Drilling Capability (mm)	No Load Speed (RPM)	Maximum Torque (N-m)	Voltage (V)	
13	0-1000	23	9.6	
Charge Time (min)	Weight (kg)	Length (mm)	Duration of each full charge	Package
45	1.4	27	More than 30 drilling cycles	2Battery 1Charger 1Key

- This is a professional cordless drill suitable for general purpose drilling for all type of woods and metal, which can be used in automotive repairs, construction and home improvements works

LED Light

Packing: 1 Order NO.: 702003

ETB14410A



Length (mm)	Weight (kg)	Battery Pack	Battery Charger	Duration of each full charge
228	0.2	ETB14419A (not included)	ETB14401A (not included)	14 hours continuous

- LED bulb provides long life and low power draw for less job interruptions
- 90 degree pivoting head puts the light ray where you need it
- Faceted reflector provides bright uniform beam
- Perfectly balanced compact shape with surrounding soft-grip handle reduces fatigue
- Slide-on battery provides better contact and safer operation since battery won't drop

Battery, 14.4V

Packing: 1 Order NO.: 702005

ETB14419A



- 14.4V battery pack for Blue-Point ETB series cordless tools
- Slide-on battery provides better contact and safer operation since battery won't drop
- 45 minutes charging time using ETB14401A charger

Charger, 14.4V/220V

Packing: 1 Order NO.: 702006

ETB14401A



- 14.4V battery charger for batteries used on Blue-Point ETB series cordless tools
- 45 minutes charging time on ETB14419A battery

3/8" Drive, Shallow, 6pt.

3/8" Drive, Deep, 6pt.

3/8" Drive, Shallow, 6pt.



Stock No.	Size (mm)	Packing	Order No.
BLPSMIM387	7	6	703001
BLPSMIM388	8	6	703002
BLPSMIM389	9	6	703003
BLPSMIM3810	10	6	703004
BLPSMIM3811	11	6	703005
BLPSMIM3812	12	6	703006
BLPSMIM3813	13	6	703007
BLPSMIM3814	14	6	703008
BLPSMIM3815	15	6	703009
BLPSMIM3816	16	6	703010
BLPSMIM3817	17	6	703011
BLPSMIM3818	18	6	703012
BLPSMIM3819	19	6	703013

Stock No.	Size (mm)	Packing	Order No.
BLPLSMIM387	7	6	703014
BLPLSMIM388	8	6	703015
BLPLSMIM389	9	6	703016
BLPLSMIM3810	10	6	703017
BLPLSMIM3811	11	6	703018
BLPLSMIM3812	12	6	703019
BLPLSMIM3813	13	6	703020
BLPLSMIM3814	14	6	703021
BLPLSMIM3815	15	6	703022
BLPLSMIM3816	16	6	703023
BLPLSMIM3817	17	6	703024
BLPLSMIM3818	18	6	703025
BLPLSMIM3819	19	6	703026

Stock No.	Size (inches)	Packing	Order No.
BLPSIM3814	1/4	6	703027
BLPSIM38516	5/16	6	703028
BLPSIM3838	3/8	6	703029
BLPSIM38716	7/16	6	703030
BLPSIM3812	1/2	6	703031
BLPSIM38916	9/16	6	703032
BLPSIM3858	5/8	6	703033
BLPSIM381116	11/16	6	703034
BLPSIM3834	3/4	6	703035

- Designed for maximum engagement on 6 point fasteners
- Suitable for use with pneumatic and electric impact wrenches
- Specially heat treated for impact use to provide long life, safety, and durability
- Drive end features pin retention hole and groove

3/8" Drive, Deep, 6pt.



Stock No.	Size (inches)	Packing	Order No.
BLPLSIM3814	1/4	6	703036
BLPLSIM38516	5/16	6	703037
BLPLSIM3838	3/8	6	703038
BLPLSIM38716	7/16	6	703039
BLPLSIM3812	1/2	6	703040
BLPLSIM38916	9/16	6	703041
BLPLSIM3858	5/8	6	703042
BLPLSIM381116	11/16	6	703043
BLPLSIM3834	3/4	6	703044

- Designed for maximum engagement on 6 point fasteners
- Suitable for use with pneumatic and electric impact wrenches
- Specially heat treated for impact use to provide long life, safety, and durability
- Drive end features pin retention hole and groove

3/8" Drive Universal Joints

Packing: 6 Order NO.: 703046

BLPJIM38



Stock No.	Size (inches)
BLPJIM38	3/8 male X 3/8 female

- Specially heat treated for impact use to provide long life, safety, and durability
- Suitable for use with pneumatic and electric impact wrenches
- Drive end features pin retention hole and groove

1/4" Drive, Impact Adaptor

Packing: 6 Order NO.: 703045

BLPAIM3814



Stock No.	Size (inches)
BLPAIM3814	3/8 male X 1/4 female

3/8" Drive Extension



Stock No.	Size (inches)	Packing	Order No.
BLPEXIM383	3	6	703047
BLPEXIM386	6	6	703048

3/8" Drive Adaptor

Packing: 6 Order NO.: 703049

BLPAIM1238



Stock No.	Size (inches)
BLPAIM1238	1/2 male X 3/8 female

- Specially heat treated for impact use to provide long life, safety, and durability
- Suitable for use with pneumatic and electric impact wrenches
- Drive end features pin retention hole and groove

1/2" Drive, Shallow, 6pt.



Stock No.	Size (mm)	Packing	Order No.	Stock No.	Size (mm)	Packing	Order No.
BLPSMIM1210	10	6	703050	BLPSMIM1219	19	6	703059
BLPSMIM1211	11	6	703051	BLPSMIM1221	21	6	703060
BLPSMIM1212	12	6	703052	BLPSMIM1222	22	6	703061
BLPSMIM1213	13	6	703053	BLPSMIM1223	23	6	703062
BLPSMIM1214	14	6	703054	BLPSMIM1224	24	6	703063
BLPSMIM1215	15	6	703055	BLPSMIM1227	27	6	703064
BLPSMIM1216	16	6	703056	BLPSMIM1229	29	6	703065
BLPSMIM1217	17	6	703057	BLPSMIM1230	30	6	703066
BLPSMIM1218	18	6	703058	BLPSMIM1232	32	6	703067

1/2" Drive, Deep, 6pt.



Stock No.	Size (mm)	Packing	Order No.
BLPLSMIM1210	10	6	703068
BLPLSMIM1211	11	6	703069
BLPLSMIM1212	12	6	703070
BLPLSMIM1213	13	6	703071
BLPLSMIM1214	14	6	703072
BLPLSMIM1215	15	6	703073
BLPLSMIM1216	16	6	703074
BLPLSMIM1217	17	6	703075
BLPLSMIM1218	18	6	703076
BLPLSMIM1219	19	6	703077
BLPLSMIM1221	21	6	703078
BLPLSMIM1222	22	6	703079
BLPLSMIM1224	24	6	703080
BLPLSMIM1226	26	6	703081
BLPLSMIM1227	27	6	703082
BLPLSMIM1229	29	6	703083
BLPLSMIM1230	30	6	703084
BLPLSMIM1232	32	6	703085

1/2" Drive, Shallow, 6pt.



Stock No.	Size (inches)	Packing	Order No.
BLPSIM1238	3/8	6	703086
BLPSIM12716	7/16	6	703087
BLPSIM1212	1/2	6	703088
BLPSIM12916	9/16	6	703089
BLPSIM1258	5/8	6	703090
BLPSIM121116	11/16	6	703091
BLPSIM1234	3/4	6	703092
BLPSIM121316	13/16	6	703093
BLPSIM1278	7/8	6	703094
BLPSIM121516	15/16	6	703095
BLPSIM121	1	6	703096
BLPSIMB121116	1 1/16	6	703097
BLPSIMB12118	1 1/8	6	703098
BLPSIMB12114	1 1/4	6	703099
BLPSIMB121516	1 5/16	6	703100
BLPSIMB121716	1 7/16	6	703101

1/2" Drive, Deep, 6pt.



Stock No.	Size (inches)	Packing	Order No.
BLPLSIM1238	3/8	6	703102
BLPLSIM12716	7/16	6	703103
BLPLSIM1212	1/2	6	703104
BLPLSIM12916	9/16	6	703105
BLPLSIM1258	5/8	6	703106
BLPLSIM121116	11/16	6	703107
BLPLSIM1234	3/4	6	703108
BLPLSIM121316	13/16	6	703109
BLPLSIM1278	7/8	6	703110
BLPLSIM121516	15/16	6	703111
BLPLSIM121	1	6	703112
BLPLSIMB12116	1 1/16	6	703113
BLPLSIMB12118	1 1/8	6	703114
BLPLSIMB121316	1 3/16	6	703115
BLPLSIMB12114	1 1/4	6	703116

- Designed for maximum engagement on 6 point fasteners
- Suitable for use with pneumatic and electric impact wrenches
- Specially heat treated for impact use to provide long life, safety, and durability
- Drive end features pin retention hole and groove

1/2" Drive Extension



Stock No.	Size (inches)	Packing	Order No.
BLPEXIM123	3	6	703117
BLPEXIM125	5	6	703118
BLPEXIM126	6	6	703119
BLPEXIM1210	10	6	703120

1/2" Impact Adaptor

Packing: 6

Order NO.: 703121

BLPAIM3812



Stock No.	Size (inches)
BLPAIM3812	3/8 male X 1/2 female

1/2" Impact Adaptor

Packing: 6

Order NO.: 703122

BLPAIM3412



Stock No.	Size (inches)
BLPAIM3412	3/4 male X 1/2 female

- Specially heat treated for impact use to provide long life, safety, and durability
- Suitable for use with pneumatic and electric impact wrenches
- Drive end features pin retention hole and groove

1/2" Drive Universal Joints

Packing: 6

Order NO.: 703123

BLPJIM12



Stock No.	Size (inches)
BLPJIM12	1/2 male X 1/2 female

- Specially heat treated for impact use to provide long life, safety, and durability
- Suitable for use with pneumatic and electric impact wrenches
- Drive end features pin retention hole and groove

3/4" Drive, Shallow, 6pt.



Stock No.	Size (mm)	Packing	Order No.	Stock No.	Size (mm)	Packing	Order No.	Stock No.	Size (mm)	Packing	Order No.	Stock No.	Size (mm)	Packing	Order No.
BLPSMIM3417	17	6	703124	BLPSMIM3428	28	6	703135	BLPSMIM3439	39	6	703146	BLPSMIM3450	50	6	703157
BLPSMIM3418	18	6	703125	BLPSMIM3429	29	6	703136	BLPSMIM3440	40	6	703147	BLPSMIM3452	52	6	703158
BLPSMIM3419	19	6	703126	BLPSMIM3430	30	6	703137	BLPSMIM3441	41	6	703148	BLPSMIM3454	54	6	703159
BLPSMIM3420	20	6	703127	BLPSMIM3431	31	6	703138	BLPSMIM3442	42	6	703149	BLPSMIM3455	55	6	703160
BLPSMIM3421	21	6	703128	BLPSMIM3432	32	6	703139	BLPSMIM3443	43	6	703150	BLPSMIM3456	56	6	703161
BLPSMIM3422	22	6	703129	BLPSMIM3433	33	6	703140	BLPSMIM3444	44	6	703151	BLPSMIM3457	57	6	703162
BLPSMIM3423	23	6	703130	BLPSMIM3434	34	6	703141	BLPSMIM3445	45	6	703152	BLPSMIM3458	58	6	703163
BLPSMIM3424	24	6	703131	BLPSMIM3435	35	6	703142	BLPSMIM3446	46	6	703153	BLPSMIM3459	59	6	703164
BLPSMIM3425	25	6	703132	BLPSMIM3436	36	6	703143	BLPSMIM3447	47	6	703154	BLPSMIM3460	60	6	703165
BLPSMIM3426	26	6	703133	BLPSMIM3437	37	6	703144	BLPSMIM3448	48	6	703155	BLPSMIM3463	63	6	703166
BLPSMIM3427	27	6	703134	BLPSMIM3438	38	6	703145	BLPSMIM3449	49	6	703156	BLPSMIM3465	65	6	703167

- Designed for maximum engagement on 6 point fasteners
- Suitable for use with pneumatic and electric impact wrenches
- Specially heat treated for impact use to provide long life, safety, and durability
- Drive end features pin retention hole and groove

3/4" Drive, Deep, 6pt.



Stock No.	Size (mm)	Packing	Order No.	Stock No.	Size (mm)	Packing	Order No.	Stock No.	Size (mm)	Packing	Order No.
BLPLSMIM3417	17	6	703169	BLPLSMIM3429	29	6	703181	BLPLSMIM3441	41	6	703192
BLPLSMIM3418	18	6	703170	BLPLSMIM3430	30	6	703182	BLPLSMIM3442	42	6	703193
BLPLSMIM3419	19	6	703171	BLPLSMIM3431	31	6	703183	BLPLSMIM3443	43	6	703194
BLPLSMIM3420	20	6	703172	BLPLSMIM3432	32	6	703184	BLPLSMIM3444	44	6	703195
BLPLSMIM3421	21	6	703173	BLPLSMIM3433	33	6	703185	BLPLSMIM3445	45	6	703196
BLPLSMIM3422	22	6	703174	BLPLSMIM3434	34	6	703186	BLPLSMIM3446	46	6	703197
BLPLSMIM3423	23	6	703175	BLPLSMIM3435	35	6	703187	BLPLSMIM3447	47	6	703198
BLPLSMIM3424	24	6	703176	BLPLSMIM3436	36	6	703188	BLPLSMIM3448	48	6	703199
BLPLSMIM3425	25	6	703177	BLPLSMIM3437	37	6	703189	BLPLSMIM3449	49	6	703200
BLPLSMIM3426	26	6	703178	BLPLSMIM3438	38	6	703190	BLPLSMIM3450	50	6	703201
BLPLSMIM3427	27	6	703179	BLPLSMIM3440	40	6	703191	BLPLSMIM3455	55	6	703202
BLPLSMIM3428	28	6	703180								

- Designed for maximum engagement on 6 point fasteners
- Suitable for use with pneumatic and electric impact wrenches
- Specially heat treated for impact use to provide long life, safety, and durability
- Drive end features pin retention hole and groove

3/4" Drive, Shallow, 6pt.



Stock No.	Size (inches)	Order No.	Stock No.	Size (inches)	Order No.
BLPSIM341116	11/16	6 703203	BLPSIMB34138	1 3/8	6 703214
BLPSIM3434	3/4	6 703204	BLPSIMB341716	1 7/16	6 703215
BLPSIM341316	13/16	6 703205	BLPSIMB34112	1 1/2	6 703216
BLPSIM3478	7/8	6 703206	BLPSIMB341916	1 9/16	6 703217
BLPSIM341516	15/16	6 703207	BLPSIMB34158	1 5/8	6 703218
BLPSIM341	1	6 703208	BLPSIMB3411116	1 11/16	6 703219
BLPSIMB341116	1 1/16	6 703209	BLPSIMB34134	1 3/4	6 703220
BLPSIMB34118	1 1/8	6 703210	BLPSIMB341316	1 13/16	6 703221
BLPSIMB341316	1 3/16	6 703211	BLPSIMB34178	1 7/8	6 703222
BLPSIMB34114	1 1/4	6 703212	BLPSIMB3411516	1 15/16	6 703223
BLPSIMB341516	1 5/16	6 703213	BLPSIMB342	2	6 703224

- Designed for maximum engagement on 6 point fasteners
- Suitable for use with pneumatic and electric impact wrenches
- Specially heat treated for impact use to provide long life, safety, and durability
- Drive end features pin retention hole and groove

3/4" Drive Extension



Stock No.	Size (inches)	Order No.
BLPEXIM343	3 1/2	6 703225
BLPEXIM344	4	6 703226
BLPEXIM346	6	6 703227
BLPEXIM347	7	6 703228
BLPEXIM348	8	6 703229
BLPEXIM3410	10	6 703230
BLPEXIM3413	13	6 703231

- Specially heat treated for impact use to provide long life, safety, and durability
- Suitable for use with pneumatic and electric impact wrenches
- Drive end features pin retention hole and groove

1" Drive, Shallow, 6pt.



Stock No.	Size (mm)	Order No.	Stock No.	Size (mm)	Order No.	Stock No.	Size (mm)	Order No.	Stock No.	Size (mm)	Order No.
BLPSMIM117	17	6 703234	BLPSMIM130	30	6 703247	BLPSMIM143	43	6 703260	BLPSMIM155	55	6 703272
BLPSMIM118	18	6 703235	BLPSMIM131	31	6 703248	BLPSMIM144	44	6 703261	BLPSMIM156	56	6 703273
BLPSMIM119	19	6 703236	BLPSMIM132	32	6 703249	BLPSMIM145	45	6 703262	BLPSMIM157	57	6 703274
BLPSMIM120	20	6 703237	BLPSMIM133	33	6 703250	BLPSMIM146	46	6 703263	BLPSMIM158	58	6 703275
BLPSMIM121	21	6 703238	BLPSMIM134	34	6 703251	BLPSMIM147	47	6 703264	BLPSMIM159	59	6 703276
BLPSMIM122	22	6 703239	BLPSMIM135	35	6 703252	BLPSMIM148	48	6 703265	BLPSMIM160	60	6 703277
BLPSMIM123	23	6 703240	BLPSMIM136	36	6 703253	BLPSMIM149	49	6 703266	BLPSMIM163	63	6 703278
BLPSMIM124	24	6 703241	BLPSMIM137	37	6 703254	BLPSMIM150	50	6 703267	BLPSMIM165	65	6 703279
BLPSMIM125	25	6 703242	BLPSMIM138	38	6 703255	BLPSMIM151	51	6 703268	BLPSMIM166	66	6 703280
BLPSMIM126	26	6 703243	BLPSMIM139	39	6 703256	BLPSMIM152	52	6 703269	BLPSMIM167	67	6 703281
BLPSMIM127	27	6 703244	BLPSMIM140	40	6 703257	BLPSMIM153	53	6 703270	BLPSMIM168	68	6 703282
BLPSMIM128	28	6 703245	BLPSMIM141	41	6 703258	BLPSMIM154	54	6 703271	BLPSMIM169	69	6 703283
BLPSMIM129	29	6 703246	BLPSMIM142	42	6 703259						

- Designed for maximum engagement on 6 point fasteners
- Suitable for use with pneumatic and electric impact wrenches
- Specially heat treated for impact use to provide long life, safety, and durability
- Drive end features pin retention hole and groove

1" Drive, Deep, 6pt.



Stock No.	Size (mm)	Order No.	Stock No.	Size (mm)	Order No.	Stock No.	Size (mm)	Order No.	Stock No.	Size (mm)	Order No.
BLPLSMIM117	17	6 703283	BLPLSMIM125	25	6 703291	BLPLSMIM133	33	6 703299	BLPLSMIM141	41	6 703306
BLPLSMIM118	18	6 703284	BLPLSMIM126	26	6 703292	BLPLSMIM134	34	6 703300	BLPLSMIM142	42	6 703307
BLPLSMIM119	19	6 703285	BLPLSMIM127	27	6 703293	BLPLSMIM135	35	6 703301	BLPLSMIM143	43	6 703308
BLPLSMIM120	20	6 703286	BLPLSMIM128	28	6 703294	BLPLSMIM136	36	6 703302	BLPLSMIM146	46	6 703309
BLPLSMIM121	21	6 703287	BLPLSMIM129	29	6 703295	BLPLSMIM137	37	6 703303	BLPLSMIM149	49	6 703310
BLPLSMIM122	22	6 703288	BLPLSMIM130	30	6 703296	BLPLSMIM138	38	6 703304	BLPLSMIM150	50	6 703311
BLPLSMIM123	23	6 703289	BLPLSMIM131	31	6 703297	BLPLSMIM140	40	6 703305	BLPLSMIM155	55	6 703312
BLPLSMIM124	24	6 703290	BLPLSMIM132	32	6 703298						

- Designed for maximum engagement on 6 point fasteners
- Suitable for use with pneumatic and electric impact wrenches
- Specially heat treated for impact use to provide long life, safety, and durability
- Drive end features pin retention hole and groove

3/4" Drive Universal Joint

Packing: 6 Order NO.: 703233

BLPJIM34



Stock No.	Size (inches)
BLPJIM34	3/4 male X 3/4 female

3/4" Drive Adaptors

Packing: 6 Order NO.: 703232

BLPAIM1234



Stock No.	Size (inches)
BLPAIM1234	1/2 male X 3/4 female

3/4" Drive Adaptor

Packing: 6 Order NO.: 703316

BLPAIM134



Stock No.	Size (inches)
BLPAIM134	1 male X 3/4 female

- Specially heat treated for impact use to provide long life, safety, and durability
- Suitable for use with pneumatic and electric impact wrenches
- Drive end features pin retention hole and groove

1" Drive Extension



Stock No.	Size (inches)	Packing	Order No.
BLPEXIM17	7	6	703313
BLPEXIM113	13	6	703314

- Specially heat treated for impact use to provide long life, safety, and durability
- Suitable for use with pneumatic and electric impact wrenches
- Drive end features pin retention hole and groove

1" Drive, Universal Joint

Packing: 6 Order NO.: 703315

BLPJIM1



Stock No.	Size (inches)
BLPJIM1	7

1" Drive Adaptor

Packing: 6 Order NO.: 703317

BLPAIM341



Stock No.	Size (inches)
BLPAIM341	3/4 male X 1 female

- Specially heat treated for impact use to provide long life, safety, and durability
- Suitable for use with pneumatic and electric impact wrenches
- Drive end features pin retention hole and groove

1" Drive Adaptor

Packing: 6 Order NO.: 703318

BLPAIM1121



Stock No.	Size (inches)
BLPAIM1121	1 1/2 male X 1 female

Regulator, Combination Air Line

Packing: 1 Order NO.: 704001

AHRB200



Inlet/Outlet Port Size	1/2" NPT (F)
Adjustable Pressure Range	5-120 PSIG (5-8.5 kgf/cm ²)
Maximum Service Pressure	140 PSIG (9.9 kgf/cm ²)
Oil Capacity	80 ml
Operating Temperature Range Pressure	41-140° F (5-60° C)

Step Drill Set, 3 pcs

Packing: 1 Order NO.: 704005

YAS203A



Stock No.	Hole Sizes Per Bit	Increments (inches)	Length (inches)	Shank Size (inches)	Size Range (inches)	Order No.
YA261A	13	1/32	3 1/4	1/4	1/8- 1/2	704002
YA262A	6	1/16	3 3/8	1/4	3/16- 1/2	704003
YA263A	9	1/16	2 5/8	3/8	1/4- 3/4	704004

- Includes YA261A, YA262A and YA263A (3 pcs)

Grinding Wheels Set

Packing: 1 Order NO.: 704006

ETA125A



- Use with ET1350/ET1360
- Maximum rating of 12,000 RPM

Wire Brush



Stock No.	Brush Dia. (inches)	Maximum Safe Free Speed (RPM)	Shank Size Arbor Size (inches)	Wire Diameter (inches)	Packing	Order No.
AC420A	4	20,000	5/8" x 11	0.020	1	704007
AC421A	4	20,000	M10 x 1.25	0.020	1	704008

- Knotted wire wheel
- Use for heavy duty cleaning
- Ideal for pre-welding prep and weld cleaning

Wire Wheel

Packing: 1 Order NO.: 704020

AC616



- 3" crimped wire wheel is a great general purpose cleaner
- Features individual crimped filaments that support each other while being flexible
- General applications include deburring, weld cleaning and rust and paint removal
- Use on electric and pneumatic drills
- .0118 CWS-1/4

End Brush



Stock No.	Brush Dia. (inches)	Shank Size Arbor Size (inches)	Wire Diameter (inches)	Maximum Rated RPM	Packing	Order No.
AC10302	1/2	1/4	.014	25,000	1	704009
AC10306	3/4	1/4	.014	22,000	1	704010

- Features individual crimped filaments that support each other while being flexible
- Ideal for cleaning right angles

Wire Brush



Stock No.	Brush Dia. (inches)	Shank Size Arbor Size (inches)	Wire Diameter (inches)	Maximum Rated RPM	Packing	Order No.
AC17D	1	1/4	.006	20,000	1	704011
AC243	3	5/8 - 11	.014	14,000	1	704012

- Features individual crimped filaments that support each other while being flexible
- Use for medium duty general purpose cleaning

Flap Discs



Stock No.	Diameter (inches)	Type	Grit	Quantity to Pack	Packing	Order No.
AC2Z40T27MP	2	27	40	10	1	704013
AC2Z60T27MP	2	27	60	10	1	704014
AC2Z80T27MP	2	27	80	10	1	704015
AC4Z60T27MP	4	27	60	10	1	704019

Flap Wheels



Stock No.	Diameter (inches)	Type	Grit	Quantity to Pack	Packing	Order No.
AC3160FWMP	3	—	60	10	1	704017
AC3180FWMP	3	—	80	10	1	704018
AC31120FWMP	3	—	120	10	1	704016

Cut Off Wheel

Packing: 1 Order NO.: 704021



- Use for metal notching and bolt cutting
- Use on 4 1/2" grinders with 5/8" x 11 thread arbor
- Re-order in multi-packs

Grinding Wheel

Packing: 1 Order NO.: 704022



- Use for rough grinding applications
- Use on 4 1/2" grinders with 5/8" x 11 thread arbor
- Re-order in multi-packs

Wool Buffing Pad

Packing: 1 Order NO.: 704023



- Ideal for cutting, buffing, and removal of scratches and paint imperfections
- 1 1/2" wool pile last longer than standard wool pads
- Washable for easy clean up
- Use for base and clear coats, acrylic, enamel, lacquer, urethane, fiberglass, plastics and other applications
- Can be used with AT450BP, AT460BP and ETB1580B Polishers

Blow Gun

Packing: 1 Order NO.: 704024



- Tapered, rubber tip for a leak proof connection between gun and fluid line
- Won't mar surfaces
- Vinyl coated control lever
- Hanging hook for storage
- 4 1/2" long

Blow Gun

Packing: 1 Order NO.: 704025



- Pistol grip style with front full size trigger
- Infinitely variable flow
- 10 1/4" long

Air Hoses

Packing: 1 Order NO.: 704026



- Extremely lightweight for easy maneuverability
- Reinforced construction eliminates layer separation resulting from expansion and contraction during pulsating operations
- More abrasion resistant than PVC and rubber hoses
- Easy to wrap and store even in subzero weather
- UV stabilized for longer outdoor life
- Strain relief features a tight bending radius to virtually eliminate hose kinking
- Reusable fittings and strain reliefs for longer life

Air Line Couplers and Adaptors



Stock No.	Body Size (inches)	Style	Thread Size	Packing	Order No.
AHC26C	1/4	Lincoln	1/4"-18 NPT	1	704027
AHC26MC	1/4	Lincoln	1/4"-18 NPT	1	704029
AHC26FC	1/4	Lincoln	1/4"-18 NPT	1	704038

Air Line Couplers and Adaptors



Stock No.	Body Size (inches)	Style	Thread Size	Packing	Order No.
AHC24C	1/4	True-Flate	1/4"-18 NPT	1	704048
AHC24MC	1/4	True-Flate	1/4"-18 NPT	1	704049
AHC24FC	1/4	True-Flate	1/4"-18 NPT	1	704050

Air Line Couplers and Adaptors



Stock No.	Body Size (inches)	Style	Thread Size	Packing	Order No.
AHC25C	3/8	True-Flate	1/4"-18 NPT	1	704031
AHC25MC	3/8	True-Flate	1/4"-18 NPT	1	704043
AHC25FC	3/8	True-Flate	1/4"-18 NPT	1	704040

Air Line Couplers and Adaptors



Stock No.	Body Size (inches)	Style	Thread Size	Quick Coupler Male	Packing	Order No.
AHC23PMC	1/4	ARO	1/4"-18 NPT	AHC23PMC	1	704039
AHC23C	1/4	ARO	1/4"-18 NPT	AHC23PMC	1	704037
AHC23MC	1/4	ARO	1/4"-18 NPT	AHC23PMC	1	704051
AHC23FC	1/4	ARO	1/4"-18 NPT	AHC23PMC	1	704047

Air Line Couplers and Adaptors



Stock No.	Body Size (inches)	Style	Thread Size	Quick Coupler Male	Packing	Order No.
AHC21PMC	1/4	Industrial Interchange	1/4"-18 NPT	AHC21PMC	1	704036
AHC21C	1/4	Industrial Interchange	1/4"-18 NPT	AHC21PMC	1	704052
AHC21MC	1/4	Industrial Interchange	1/4"-18 NPT	AHC21PMC	1	704041
AHC21FC	1/4	Industrial Interchange	1/4"-18 NPT	AHC21PMC	1	704032

Air Line Couplers and Adaptors



Stock No.	Body Size (inches)	Style	Thread Size	Packing	Order No.
AHC22D	3/8	Industrial Interchange	1/4"-18 NPT	1	704028
AHC22MC	3/8	Industrial Interchange	1/4"-18 NPT	1	704030
AHC22FC	3/8	Industrial Interchange	1/4"-18 NPT	1	704046

Air Line Couplers and Adaptors



Stock No.	Body Size (inches)	Style	Thread Size	Packing	Order No.
AHC28C	3/8	Industrial Interchange	3/8"-18 NPT	1	704035
AHC28MC	3/8	Industrial Interchange	3/8"-18 NPT	1	704044
AHC28FC	3/8	Industrial Interchange	3/8"-18 NPT	1	704034

Air Line Couplers and Adaptors



Stock No.	Body Size (inches)	Style	Thread Size	Packing	Order No.
AHC27C	1/2	Industrial Interchange	1/2"-14 NPT	1	704045
AHC27FC	1/2	Industrial Interchange	1/2"-14 NPT	1	704042

Air Line Couplers and Adaptors

Packing: 1 Order NO.: 704033



Stock No.	Body Size (inches)	Style	Thread Size
AHC21PC	1/4	Rigid Mounting	1/4"-18 NPT

Cobalt Drill Bit Set , 21 pcs

Packing: 1 Order NO.: 704053



- DBBPC1/16 thru DBBPC3/8 (21 pcs) (1/16" to 3/8") in metal drill bit index

HSS Drill Bit Set , 21 pcs

Packing: 1 Order NO.: 704054



- DBBP1/16 thru DBBP3/8 (21 pcs) (1/16" to 3/8") in metal drill bit index

Titanium Coated Drill Bit Set, 13 pcs

Packing: 1 Order NO.: 704055



- DBBPT1/16 thru DBBPT1/4 (13 pcs) (1/16" to 1/4") in metal drill bit index



Striking & Cutting Tools



When it comes to striking tools, Blue-Point's lineage stretches back to 1940 when the company first produced punches and chisels that managed to penetrate and cut through quarter-inch steel. That was a remarkable achievement then.

The range today includes other selection of tools for various striking and cutting applications, bearing the same trademark hardness and toughness. Our wide range of superior hammers and cutting tools set us apart from the competition.

Hammers	100
Punches & Chisels	102
Cutting Tools	103

Ball Peen - Fiberglass Handle

Soft Face

Hickory Handle

BH232A



Stock No.	Weight (oz.)	Handle Length (inches)	Replacement Handle	Packing	Order No.
BPN8B	8	11	BPNH8B	1	801001
BPN12B	12	12	BPNH12B	1	801002
BPN16B	16	13	BPNH12B	1	801003
BPN24B	24	14	BPNH24B	1	801004
BPN32B	32	16	BPNH24B	1	801005

Stock No.	Weight (oz.)	Length (inches)
BH232A	32	13

- Combination steel and soft face dead blow
- One-piece urethane construction
- The 13" long fiberglass handle has a plastic, shock-absorbing grip
- Tip diameter is 1 5/8"
- Includes two replaceable tips: soft (BH232-2) and hard (BH232-3)
- Optional nylon tip (BH232-4)

Stock No.	Description	Weight (oz.)	Head Length (inches)	Overall Length (inches)	Replacement Handle	Packing	Order No.
BH141A	Cross Peen	32	4 1/2	15	BPH20C	1	801006
BH142A	Cross Peen	40	5	15	BPH40C	1	801007

Rubber Head Mallet

Ball Peen - Wood Handle

Soft Blow

BF620C

New

BF623



Stock No.	Length (inches)	Face Dimensions (inches)
BF620C	13 1/4	3 3/4 x 2 1/4

- Solid rubber head
- 11" Hardwood handle
- Ideal for replacing hubcaps, bodywork, etc

Stock No.	Weight (oz.)	Packing	Order No.
BPB4	4	1	801013
BPB8	8	1	801014
BPB12	12	1	801015
BPB16	16	1	801016
BPB24	24	1	801017
BPB32	32	1	801018
BPB40	40	1	801019
BPB48	48	1	801020

Stock No.	Length (inches)	Face Dimensions (inches)	Head Color
BF623	12 1/2	1 7/8 x 2 1/8	Blue

- Use on all types of surfaces and assemblies including metal, glass, plastic and wood
- Conforms to irregular surfaces
- Designed for maximum surface contact
- Low rebound
- Dissipates hand jarring shock
- Resists most chemicals
- Wood handle
- Reduces denting and marring

Soft Face

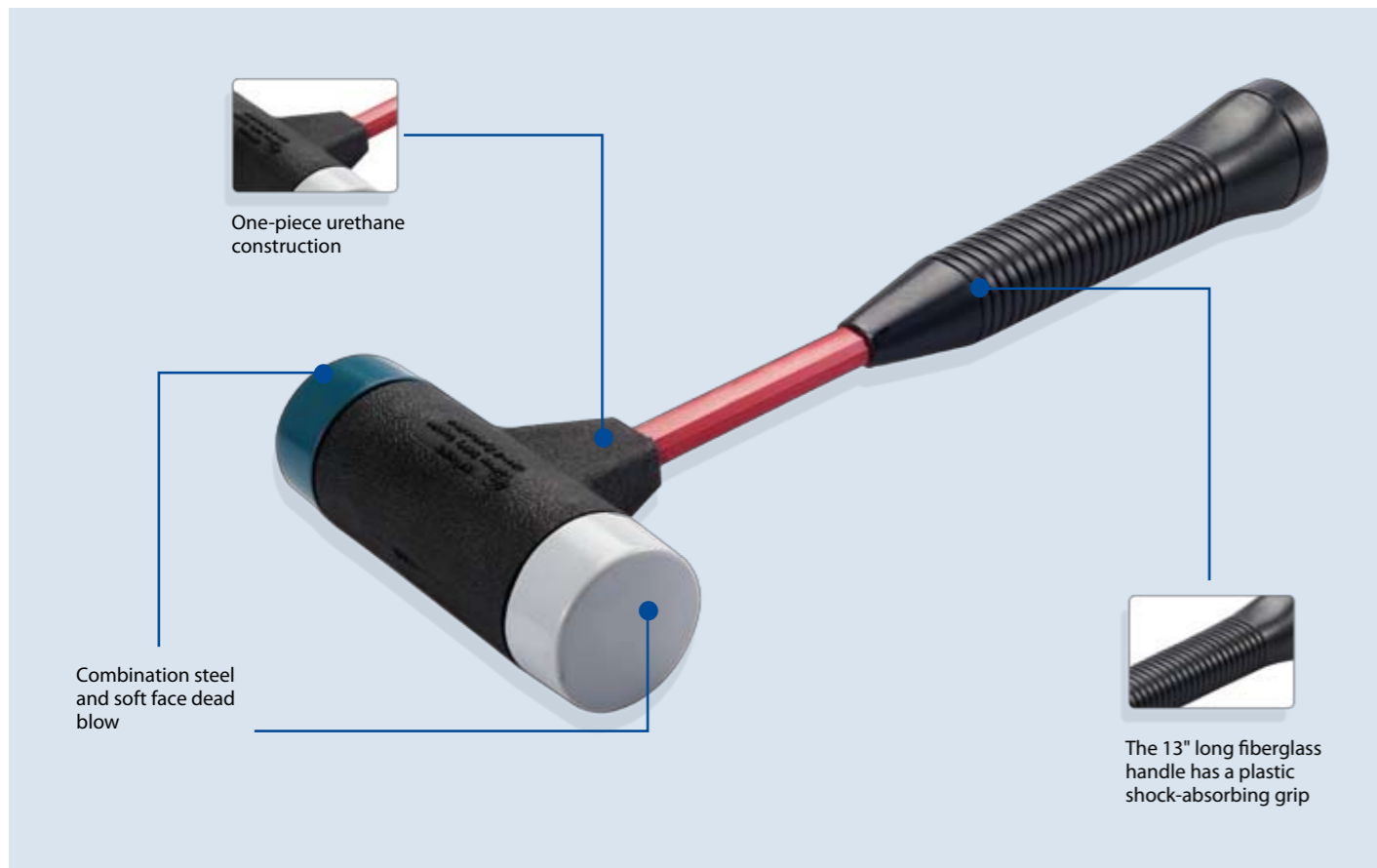

Ball Peen - Wood Handle

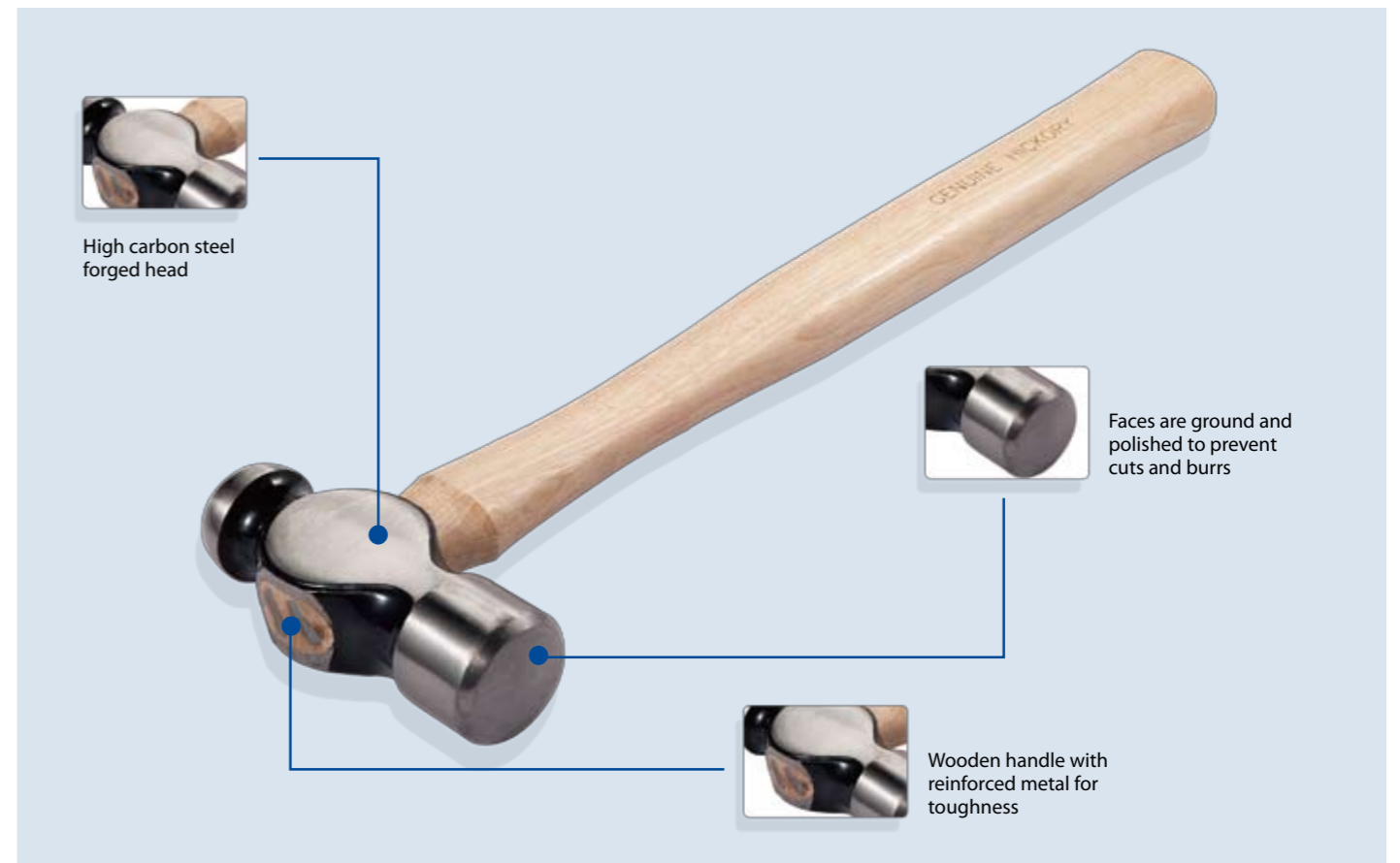

Brass Hammer



Stock No.	Weight (lbs.)	Length (inches)	Packing	Order No.
HBR15	1 1/2	12	1	801011
HBR25	2 1/2	12	1	801012

- Non-sparking/non-marring surface for many applications
- Brass head absorbs blow and reduces rebound
- Flat surface for even distribution of blow
- Fiberglass handle for strength
- Comfortable, non-slip handle grip

Fiberglass Hammer



Stock No.	Description	Weight, lbs	Striking Face Dia. (inches)	Handle Length (inches)	Overall Length (inches)	Replacement Handle	Packing	Order No.
BC4SG	Cross Peen	4	1 1/2	12	14	BD4SG-1	1	801021
BD4SG	Engineer	4	1 1/2	12	14	BD4SG-1	1	801022
HD4SG	Hand Drilling	4	1 1/2	8 3/4	10 3/4	BD4SG-1	1	801023

- Fiberglass handle dampens vibration and provides extra strength and safety
- Handle is epoxy-welded to hammer head and will withstand 8,000 lbs. of separation force
- Handle is resistant to dry rot, warp and splintering
- Comfortable, non-slip handle grip
- Materials will resist most shop chemicals

Punch Set

Packing: 1 Order NO.: 802001

DPFT528A



- For transferring hole patterns
- Set includes punches from 3/32" to 1/2" in 1/64" increments plus 17/32"
- Each punch is marked with its size and manufactured from tempered steel to promote long tool life
- A metal index provides convenient storage
- Punches are 4 7/8" in length

Automatic Center Punch

Packing: 1 Order NO.: 802002

YA879A



- Single handed operation
- Design eliminates need for striking with hammer
- Adjustable spring tension cap
- Hardened steel point is replaceable
- 1/2" diameter
- 5" long

Automatic Center Punch

Packing: 1 Order NO.: 802003

YA900



- Strikes blow when pressure is applied-no hammer needed
- Cap adjusts force of blow
- 7/16" diameter
- 4 3/4" long

Scraper Set

Packing: 1 Order NO.: 802004

PKB500A



Stock No.	Handle Length (inches)	Blade Length (inches)	Blade Width (inches)	Blade Style	Edge	Packing	Order No.
PKB50A	4 7/8	3 1/2	2	Stiff	Straight	1	802005
PKB52A	4 7/8	3 19/32	1 1/4	Stiff	Straight	1	802006
PKB53A	4 7/8	3 19/32	1 1/4	Stiff	Single Bevel	1	802007

- Set includes PKB50A, PKB52A and PKB53A Putty Knives Scrapers
- Spring tempered, solid brass blades are non-marring, non-sparking, non-magnetic and non-corrosive
- Soft molded rubber handles maximize hand grip, are easy to clean and are resistant to most solvents
- Broad hilt design helps protect against hand slipping when scraping
- Stiff blade style

Scraper Set

Packing: 1 Order NO.: 802008

PK500A



Stock No.	Blade Length (inches)	Blade Width (inches)	Blade Style	Edge	Packing	Order No.
PK50A	3 1/2	2	Flexible	Straight	1	802009
PK52A	5 19/32	1 1/4	Flexible	Straight	1	802010
PK53A	2 19/32	1 1/4	Stiff Chisel	Single Bevel	1	802011

- Set includes PK50A, PK52A and PK53A Putty Knives Scrapers
- Features full length steel blades for strength and durability
- Soft molded rubber handles maximize hand grip, are easy to clean and are resistant to most solvents
- Broad hilt design helps protect against hand slipping when scraping

Scraper set

Packing: 1 Order NO.: 802012

USS103



Stock No.	Blade Style	Blade Length (inches)	Length (inches)	Packing	Order No.
US710	Spoon	3 1/2	8	1	802013
US711	Chisel Tip	2 1/2	7 1/8	1	802014
US712	Oyster	2 1/8	6 3/4	1	802015

- Set includes US710, US711 and US712 Knife Blade Scrapers
- Remove gaskets, sealers and other caked on materials
- Blade edge designed to work effectively in both push and pull directions
- Stainless steel blades for durability
- Polished blades clean up easily
- Comfortable composite handles feature a contour thumb stop for maximum control and a wide hilt for control

Aviation Snips



Stock No.	Description	Length (inches)	Packing	Order No.
DAR9A	Green handled; Right hand cut	9 1/2	1	803010
DAL9A	Red handled; Left hand cut	9 1/2	1	803011

- Offset blades allow cut material to flow beneath your hand without curling
- Maneuverable for angle cutting or pattern configurations
- Cuts up to 18 ga. mild steel
- 1 1/8" cutting edge

Tin Snips

Packing: 1 Order NO.: 704023



Stock No.	Description	Blades Length (inches)	Length (inches)	Packing	Order No.
CD7A	Duckbill Snips	1 1/2	7	1	803005
CD10A	Duckbill Snips	2 1/4	10	1	803006
CD12A	Combination Snips	3	12	1	803007
CD16A	Bulldog Snips	2 1/2	16	1	803008

- Cut straight, circular, or irregular patterns; right or left cuts

Walnut Handled Scraper



Stock No.	Blade Length (inches)	Blade Width (inches)	Blade Style	Edge	Length (Inches)	Packing	Order No.
PKWLR53A	5 1/2	1 1/4	Straight	Chisel	9 1/2	1	802018
PKWSS53A	2 3/4	1 1/4	Straight	Chisel	6 3/4	1	802019

- Quality crafted for hard scraping applications
- Walnut wood handle for comfort
- Full length heavy duty blades for strength
- Large steel cap for striking capability
- Remove gaskets, sealants and body weld breakaway

Wooden Handle Scraper



Stock No.	Handle Material	Handle Length (inches)	Blade Width (inches)	Blade Style	Edge	Packing	Order No.
PK23A	Maple	3 7/8	1 1/4	Heavy Chisel	Single Bevel	1	802020

- Mirror finished hardened steel blade extends through hardwood handle, solidly riveted for durability
- Redwood handle has metal bolster where handle meets blade

Scissors, Shop, Heavy Duty

Packing: 1 Order NO.: 803012

HDSCISSORS



- For leather, cloth, plastic, rubber sheet, rubber hose, cardboard, gasket material, rope and many other materials
- Stainless steel blade and fasteners
- Precision ground and heat treated for a long lasting edge
- Ergonomic handles can be used right or left handed

Vinyl Cutter



Stock No.	Packing	Order No.
YA444B	1	803013
YA444A-1	1	803014

- Cleanly cuts plastic, rubber, vinyl, upholstery, leather, hoses, and rope
- ERGO Grip handle with safety lock
- Blade storage in handle
- Includes three (YA444B1) stainless steel replacement blades
- **YA444A-1 Replacement Blades**
Includes 3 replacement blades and anvil for YA444B

Cutter, Multi-Purpose



Stock No.	Packing	Order No.
YA580A	1	803015
YA580A-1	1	803020

- Features auto locking, fully retractable blade
- All metal body is black with blue cap and pocket clip
- Includes (1) premium steel 13 pt. snap blade
- Overall length of 5 3/8" (136.5mm)
- **YA580A-1 Replacement Blades**
Pack of 5

Metal Cutting Shears

Packing: 1 Order NO.: 803004

DAS30



Stock No.	Description	Length (inches)	Packing	Order No.
DAL10B	Red handled; Left hand cut	10 1/4	1	803001
DAR10B	Green handled; Right hand cut	10 1/4	1	803002
DAS10B	Yellow handled; Straight cut	10 1/4	1	803003

- Serrated cutting blades
- Narrow bodies allow metal to pass over shears
- Oil and grease resistant grips
- DAS30 Set includes DAL10B, DAR10B and DAS10B

Shears, Angled, Heavy Duty

Packing: 1 Order NO.: 803009

SNP2A



- For leather, cloth, plastic, rubber sheet, rubber hose, cardboard, gasket material, rope and many other materials
- Stainless steel blades and fasteners ensure durability
- Precision ground and heat treated for a long lasting edge
- Ergonomic handles can be used right or left handed
- Top of blade is notched for hard wire and twine
- Locking switch ensures safety during storage
- Control switch allows blades to be held in a tighter position for easier handling
- Angled shears allow easier cutting through flat materials
- Soft mold grip for comfort and control

Cutter, Multi-Purpose

Packing: 1 Order NO.: 803017

LBUK1



Stock No.	Packing	Order No.
YA581A	1	803016
YA581A-1	1	803023

- Has three blades with eight snap off points.
- Minimum blade wobble
- Fully retractable
- **YA581A-1 Replacement Blades**
• Pack of 10

Utility Knife

Packing: 1 Order NO.: 803017

LBUK1



- Convenience and good looks of a folding lock back knife with easily replaceable two notch razor blades
- Folding lock back blade, hardwood handle with belt clip and thumb stud for one-hand opening
- Includes utility knife and leather pouch (both with Blue-Point® logo) plus 10 replacement blades
- Uses UKBU10 (10 pack) or UKBU50PK (50 pack) replacement blades

Utility Knife

Packing: 1 Order NO.: 803018

LBUK2



- Thumb pad allows controlled application of pressure
- Blades are easily replaced with a flip of a switch
- Blade storage under spring loaded door
- Includes leather pouch with belt loop plus 5 replacement blades

Utility Knife

Packing: 1 Order NO.: 803019

LBUK3



- Solidly constructed lock back utility knife sports polished, stainless steel handle with TPR grips for durability and control
- Two notch blades are easily changed with quick change switch
- Includes belt pouch and 10 titanium replacement blades
- Uses UKBU10 (10 pack) or UKBU50PK (50 pack) replacement blades

Utility Knife Blades

Packing: 1 Order NO.: 803022

UKBU50PK



- High performance blades are perfect for thick, dense materials
- Bi-metal construction allows blade to bend/flex without breaking under normal work conditions
- Bi-metal lasts up to 3 times longer than normal utility knife blades
- Two-notch blade design fits most standard utility knives
- Convenient dispenser provides storage for used blades
- Use with LBUK1, LBUK2 and LBUK3 Utility Knives
- Dispenser of 50 blades

Utility Knife Blades

Packing: 1 Order NO.: 803021

UKBU10



- High performance blades are perfect for thick, dense materials
- Bi-metal construction allows blade to bend/flex without breaking under normal work conditions
- Bi-metal lasts up to 3 times longer than normal utility knife blades
- Two-notch blade design fits most standard utility knives
- Use with LBUK1, LBUK2 and LBUK3 Utility Knives
- Pack of 10 blades

Ratcheting Tube Cutter

Packing: 1 Order NO.: 803034

TC123CR



- TC123C cutter and TC123CRH handle combined into one unit

Metric Bubble Flaring Set

Packing: 1 Order NO.: 803041

TFM428



- For automotive brake systems
- Designed for crack free bubble flares on soft wall tubing up to a wall thickness of .028"
- Adaptors included for 4.75, 6, 8, and 10mm flares
- TFM428PB storage case included

Flaring and Swaging Set

Packing: 1 Order NO.: 803040

TF275A



- 45° flare or swage soft copper, brass, or aluminum tubing
- Die blocks handle 1/8", 3/16", 1/4", 5/16", 3/8", 7/16", 1/2", 5/8", and 3/4" OD tubing
- Swages 3/16", 1/4", 5/16", 3/8", 1/2", 5/8", and 3/4" OD tubing
- TF275PB storage case included

Folding Knife

Packing: 1 Order NO.: 803028

CRKBP21



Description	Blade Type	Blade Length (inches)
Badger	Straight Edge	2 5/7
Handle Length (inches)	Opening Mechanism	Weight (oz.)
3 1/2	Assisted (Outburst™ Fire Safe™)	2.7

- Extremely fast one-handed assisted opener is quick
- Barry Gallagher design
- High carbon stainless steel blade
- Black oxide blade finish
- Stainless steel inter-frame build
- Multi-layer G10 Scales
- Stainless steel clip
- CRKT limited lifetime warranty

Folding Knife

Packing: 1 Order NO.: 803029

CRKBP22



Description	Blade Type	Blade Length (inches)
Notorious	Straight Edge	3 1/4
Handle Length (inches)	Opening Mechanism	Weight (oz.)
4 5/8	Assisted (Outburst™ Fire Safe™)	5.0

- Dual ramped thumb studs employ Outburst® assisted opening mechanism
- Stainless steel frame and back spacer with G10 composite scale overlays
- CNC machined grooves for excellent fit and finish with ample friction grooves on thumb
- Modified 3 1/2" spear point blade with re-curve and high hollow grind
- Plain edge blade for controlled, accurate and clean cuts

Tube Cutting and Double Flaring Set

Packing: 1 Order NO.: 803037

TF528D



- Contains TC28C tubing cutter and a double flaring set with a flaring bar, rod handle, yoke, and 5 adaptors: 3/16", 1/4", 5/16", 3/8", and 1/2"
- Storage case included

Tubing Cutter



Stock No.	Packing	Order No.
TC28C	1	803030
TC28B1	1	803032

- Cuts soft metal tubing ranging from 1/8" to 1" in diameter
- OD capacity is 1/8" to 1 1/8"
- Micrometer type adjustment
- Retractable locking reamer blade
- Cutter wheel is easily replaceable

TC28B1 Cutting Wheel

- Extra cutter wheel for TC28C

Double Flaring Tool Set



Stock No.	Packing	Order No.
TF5A	1	803038
TFM5A	1	803039

- Makes double or single flares on soft steel, brass, or aluminum tubing from 3/16" to 1/2" OD
- Can be used where clearance around tubing is less than 1 3/8"
- Makes a smooth fitting, crack free 45° flare
- Set includes five adaptors, yoke assembly, bar assembly, and handle
- Storage case included

TFM5A Metric Double Flaring Tool Set

- Same design as TF5A except it is for tubing with an OD from 4.75 to 10mm
- Set includes yoke, bar assembly, handle, and five adaptors: 4.75, 5, 6, 8, and 10mm
- Storage case included

Tubing Cutter



Stock No.	Packing	Order No.
TC123C	1	803031
TC123CRH	1	803035
TC123C1	1	803033

- Handles tubing from 1/8" to 5/8" OD
- Can be used where clearance around tubing is less than 1 3/8"
- 1 1/2" long when closed and 2" long when open; feed knob is 7/8" in diameter
- **TC123CRH Ratcheting Tube Cutter Handle** for TC123C tube cutter
- **TC123C1 Cutting Wheel** Extra cutter wheel for TC123C



Measuring & Other Hand Tools



You will find a good selection of measuring equipment with high accuracy and other hand tools that is of good quality in this section. We strive to offer a good balance of quality to the price in these products. And there are also a number of innovative items, like the magnetic-based flashlight, created with user friendliness in mind.

Measuring Tools	110
Flashlights	115
Safety	118
Miscellaneous	119

Feeler Gauges, 13pcs	Feeler Gauges, 25pcs	Feeler Gauges, 35pcs
Packing: 1 Order NO.: 804001	Packing: 1 Order NO.: 804002	Packing: 1 Order NO.: 804003



Stock No.	Increments	Blade Size	Style	Blade Dimensions (inches)	No. of Blades	Description
FB310B	-	.001", .0015", .002" thru .008", .010", .012", .013", .015"	General Use	1/2 x 3	13	Double stamped with U.S. and metric sizes
FB325A	.001"	.0015", .002" thru .025"	General Use	1/2 x 3	25	General Use Feeler Gauge (25 blades) Double stamped with U.S. and metric sizes
FB335	.001"	.0015", .002" thru .035"	General Use	1/2 x 3	35	Swedish feeler blade steel

Feeler Gauges, 26pcs	Feeler Gauges, 25pcs	Feeler Gauges, 12pcs
Packing: 1 Order NO.: 804007	Packing: 1 Order NO.: 804008	Packing: 1 Order NO.: 804009



Stock No.	Increments	Blade Size	Style	Blade Dimensions (inches)	No. of Blades	Description
FB326B	.001"	.008", .010", .012", .013", .015", .017", .018", .020", .022", .024", .026", .028", .030", .032", .035"	Combination Feeler/Ignition Gauge	1/2 x 3	26	Double stamped with U.S. and metric sizes
FB300A	.001"	.006" thru .030"	Bent Blade	1/2 x 3	25	Feeler Gauge Set
FB308D	.001"	.008"-.010", .011"-.013", .013"-.015", .014"-.016", .015"-.017", .017"-.019", .018"-.020", .020"-.022", .023"-.025", .025"-.027", .026"-.028", .028"-.030"	Step Blade	1/2 x 3	12	Step Feeler Gauge Set, Bent handle to clear manifolds, double stamped with U.S./Metric sizes. Blades are mounted on FBFT7 holder

Feeler Gauges, 25pcs	Feeler Gauges, 20pcs	Feeler Gauges, 18pcs
Packing: 1 Order NO.: 804004	Packing: 1 Order NO.: 804005	Packing: 1 Order NO.: 804006



Stock No.	Increments	Blade Size	Style	Blade Dimensions (inches)	No. of Blades	Description
FBL325A	.001"	.0015", .002" thru .021", .025", .027", .030", .040"	Long Blade General Use	1/2 x 12	25	Long blade, double stamped with U.S. and metric sizes
FBM320	.05mm	.05 thru 1mm	Metric General Use	1/2 x 3	20	Metric Feeler Gauge Set
FB316B	.001"	.010", .012", .013", .015" thru .022", .024" thru .026", .028", .030", .032", .035"	Short Blade Ignition/Spark Plug Gauge	1/4 x 1 3/4	18	Short Blade, Ignition/Spark Plug Gauge Set

Feeler Gauges, 22pcs	Feeler Gauges, 2pcs	Feeler Gauges, 2pcs
Packing: 1 Order NO.: 804010	Packing: 1 Order NO.: 804011	Packing: 1 Order NO.: 804012



Stock No.	Increments	Blade Dimensions (inches)	Blade Size	No. of Blades	Description
FB322	.001"	1/2 x 3 3/8	.004"-.006" thru .025"-.027"	22	"Go-No Go" blades with 2 sizes each
FB328A	—	1/2 x 3	.011"-.013", .013"-.015"	2	For valve adjustment on GM 8.2L engines, double stamped with U.S. and metric sizes
FBM322	—	1/2 x 3	.20-30mm, .40-50mm	2	10 3/4 long bent handle

Feeler Gauges, 14pcs

Packing: 1 Order NO.: 804013

FB307D



Increments	Blade Dimensions (inches)	Blade Size	No. of Blades
.001"	1/2 x 4 1/2	.008", .011" thru .014", .016" thru .018", .020", .023" thru .025", .027", .029"	14

- Bent blade cummins diesel, blade ends are bent at 90° angle: blades are secured on FB307C1 ring

Measuring Tapes

New



Stock No.	Length (meter)	Packing	Order No.
BMPLM3	3	1	804018
BMPLM5	5	1	804019

- Tough and durable construction
- Dual scale-- metric and imperial

Measuring Tapes

New



Stock No.	Length (meter)	Packing	Order No.
BMPM3	3	1	804015
BMPM5	5	1	804016
BMPM8	8	1	804017

- Rubberized coating for better grip
- Tape auto-lock when extended
- Dual scale-- metric and imperial
- Nylon coated tape

Long Tape, Steel, 100ft

Packing: 1 Order NO.: 804014

TPM100



- Includes inch/metric scale
- Quick rewind design for ease of use
- Rewinding lever conveniently stored in housing
- Non-slip grip provides confidence and comfort

Spirit Levels, 9"

Packing: 1 Order NO.: 804021

TL100A



- 9" precision measuring tool designed for close quarter work
- Magnetic strips and v-grooving make it ideal for pipe and conduit work

Angle Locator

Packing: 1 Order NO.: 804022

YA328A



- Precise, accurate tool to determine angle measurements
- Ideal for checking drive shaft angle
- Red degree indicator located behind numbers for exact reading of graduations
- English and metric scales molded into base of tool in 1/8" and DM
- Large 1 7/8" x 7/8" magnet inserted in base for secure retention

Combination Measuring Set

Packing: 1 Order NO.: 804023

SQUARECOMB12



Stock No.	Description	Packing	Order No.
SQUAREB180	Square Protractor Head	1	804026
RULER12BSQ	Steel Rulers, 12"	1	804027
SQUAREB90	Square Sliding Head	1	804025
SQUAREB45	Square Sliding Head 45°	1	804028

- Set includes SQUAREB180 Protractor, RULER12BSQ steel rule plus SQUAREB90 and SQUAREB45 sliding heads in fitted storage case

Machinist's Measuring Set

Packing: 1 Order NO.: 804024

SQUAREB12



Stock No.	Description	Packing	Order No.
SQUAREB90	Square Sliding Head	1	804025
RULER12BSQ	Steel Rulers, 12"	1	804027

- Set includes SQUAREB90 sliding head and RULER12BSQ steel rule in fitted storage case

Digital Caliper

Packing: 1 Order NO.: 804029

MCAL6A



- Gauge is 0" to 6" (0 to 150mm) in 0.0005" (0.01mm) resolutions
- Use for inside, outside, depth and step measurements
- Inch/metric conversion with one button
- Large LCD display
- Hardened stainless steel frame
- Conform to standard : GB1214

Digital Caliper

Packing: 1 Order NO.: 804030

MCAL12A



- Essential tool for working on larger vehicles, trucks, tractors and earth moving equipment
- Range is 0" to 12" (0 to 305mm) in 0.0005" (0.01mm) resolutions
- Use for inside, outside, depth and step measurements
- Inch/metric conversion with one button
- Large LCD display with floating zero set
- Locking nut and thumb roll for smooth action
- Conform to standard : GB1214

Dial Type Caliper

Packing: 1 Order NO.: 804031

PMF147A



- Gauge is 0" to 6" in high (0.001" increments) and metric (0.1mm increments)
- Includes storage case
- Conform to standard : GB1214

Digital Micrometers



Digital Micrometers



Outside Micrometers



Stock No.	Range (mm)	Increments (mm)	Packing	Order No.
MIC1MB	0-25	0.01	1	804032
MIC2MB	25-50	0.01	1	804033
MIC3MB	50-75	0.01	1	804034
MIC4MB	75-100	0.01	1	804035
MIC5MB	100-125	0.01	1	804036

- MIC103MB Digital Metric Micrometer Set includes: MIC1MB, MIC2MB and MIC3MB

Stock No.	Range (inches)	Increments (inches)	Packing	Order No.
MIC1B	0-1	0.0001	1	804037
MIC2B	1-2	0.0001	1	804038
MIC3B	2-3	0.0001	1	804039
MIC4B	3-4	0.0001	1	804040
MIC5B	4-5	0.0001	1	804041

- MIC103B Set includes: MIC1B, MIC2B and MIC3B

Stock No.	Range (inches)	Increments (inches)	Packing	Order No.
MICB1B	0-1	0.0001	1	804042
MICB2B	1-2	0.0001	1	804043
MICB3B	2-3	0.0001	1	804044
MICB4B	3-4	0.0001	1	804045
MICB5B	4-5	0.0001	1	804046

- MICB103B Set includes: MICB1B, MICB2B, MICB3B

Inside Micrometer Set, 7 pcs

Packing: 1 Order NO.: 804047

MICINSIDE12



- Tubular design
- Range is 2" to 12" in .001" increments
- Includes inside micrometer head and a series of coil spring pressure contact rods

Electronic Digital Micrometers

Packing: 1 Order NO.: 804048

MICED1B



- Display reads to 0.00005" (0.001mm)
- Zero set for absolute and incremental measuring modes
- Auto shut-off after 10 minutes
- Insulated frame, hardened body, carbide tipped anvil, positive locking clamp and ratchet stop thimble

Depth Micrometer Set

Packing: 1 Order NO.: 804049

DM6



Stock No.	Description	Packing	Order No.
DM61	4" rod	1	804050
DM62	5" rod	1	804051
DM63	6" rod	1	804052
DM64	7" rod	1	804053
DM65	8" rod	1	804054
DM66	9" rod	1	804055
DM67	Micrometer Head	1	804056

- Measure depths of slots, counterbores, holes and keyways up to 6" in depth
- 4" satin chrome base for greater stability
- Graduated in .001" increments
- Includes fitted storage case

Dividers, 6"

Packing: 1 Order NO.: 804057

PMF129



- Spring type divider has virtually no torsion or side play

Penlight, Blue

Packing: 1 Order NO.: 805001

ECFB200BL



- High intensity 3 watt LED, 100 lumen penlight
- Extremely bright light output
- Uses (3) AAA alkaline cells
- Only 6.25" in length and 1/2" in diameter
- Includes pocket clip and protective rubber tip
- Blue in color

Penlight, Silver

Packing: 1 Order NO.: 805002

ECFB200S



- High intensity 3 watt LED, 100 lumen penlight
- Extremely bright light output
- Uses three AAA alkaline cells
- Only 6.25" in length and 1/2" in diameter
- Includes pocket clip and protective rubber tip
- Silver in color

LED Headlight

Packing: 1 Order NO.: 805003

ECFHEAD1A



- LED headlight for applications requiring hands free lighting
- Bright watt LED never needs replacing
- Pivoting head and adjustable headband
- Water resistant
- 30 hours continuous run time on (3) AAA alkaline batteries

Bendable Light

Packing: 1 Order NO.: 805006

ECF1600



- Heavy duty barrel handle and switch
- Features 10 flexible shaft and 3/16" high intensity lamp
- Includes (2) AA batteries

Bendable Light

Packing: 1 Order NO.: 805007

YA5100B



- Features brilliant krypton lamp on a slender, 15" long, flexible shaft
- Includes 24" extension cover, which can make the light almost 40" long for difficult-to-view areas
- 3/16" lamp diameter
- Runs on (2) AA alkaline batteries

LED Under Hood Light

Packing: 1 Order NO.: 805011

ECUB9500AP



- Extendable lightweight aluminum holder
- Length of 47"-71" covers a wide range of vehicles
- 95 ultra bright LED's provide 900LUX at 0.5m
- Rubber coated hooks protect paintwork from damage
- Cordless design improves safety and convenience
- 4400 mAh battery provides 5 hours constant light output
- Test results show 27% brighter, +28% longer life than primary competitive unit

Rotating Light Mag Base

Packing: 1 Order NO.: 805005

ECFLED24



- 24 high output LEDs project light in wide area
- Provides 40 lumens light output
- (3) AAA alkaline cells provide 4.5 hours of light
- Strong magnet mounts securely on any magnetic surface
- Mounts under-hood, under-dash, under-car wherever it is needed
- Direct light to any angle using rotating magnetic base
- Keeps hands free to do the work, while lighting the work area

Aluminum Police Style Flashlight

Packing: 1 Order NO.: 805009

ECF201A



- 3 watt LED flashlight features a K2 Luxeon LED that produces 130 lumens
- The flashlight body is aerospace grade extruded aluminum with heavy anodization
- Average run time is 10-hours on 2D alkaline batteries
- Reflector is highly polished for maximum light output
- The switch is self cleaning
- Water and shock resistant
- Requires 2 "D" cell batteries (not included)

Rechargeable Shop Light

Packing: 1 Order NO.: 805014

ECFBP20AP



New

- IP65 rating, heavy duty and robust
- Vapor, water and dust proof
- Rechargeable, Li-ion battery with 4 hours constant output
- 3 pcs magnets, totally hand free works, easier for technicians to operate
- 1 hook new design , rotate 360 degree
- 1 Stand to support this light work on 3 angles
- 180 degree bendable. Offering all lighting angle possibilities.
- CE/UL certificated charger

Rechargeable LED Shop Light

Packing: 1 Order NO.: 805013

ECFLED215AP



- Rechargeable and cordless compact shop light that can be taken anywhere
- 21 front-facing LEDs provide high light output to work surfaces
- 5 LED spot light provides up to 15 hours of continuous illumination
- Multi-function switch toggles between front and top LED illumination
- 180° folding design offers the ultimate in flexible positioning
- Dual magnetic design for parallel use or multi angle

Rechargeable LED Shop Light



High output LED

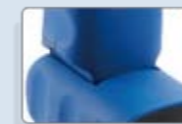

Spring-loaded extendable hooks to fit any bonnet size



Portable & cordless for convenience and safety



Hooks are removable for general use



Aluminium hooks for light weight and corrosion resistance with rubber coating to protect bonnet



Magnetic base for attaching to metal surfaces

Washable Work Gloves



Stock No.	Size	Color	Packing	Order No.
GLOVE103MA	Medium	Black	1	806003
GLOVE103LA	Large	Black	1	806001
GLOVE103XLA	X-Large	Black	1	806005
GLOVE103MAB	Medium	Blue	1	806004
GLOVE103LAB	Large	Blue	1	806002
GLOVE103XLAB	X-Large	Blue	1	806006

- Gloves feature stretch knit with padded back to provide extra feel and flexibility to grasp small objects
- Extra knuckle protection on back of fingers
- Heat resistant synthetic double layered leather palm for longer life
- Elastic cuff with hook and loop closure

Abrasion Resistant Nitrile Gloves



Stock No.	Size	Packing	Order No.
GLOVE400S	Small	3	806009
GLOVE400M	Medium	3	806008
GLOVE400L	Large	3	806007
GLOVE400XL	X-Large	3	806010
GLOVE400XXL	XX-Large	3	806011

- Nitrile dipped coating for protection on dirty jobs
- Ergonomically pre-curved design gives you comfort at all times
- High abrasion resistance protects hand on sharp edges and rough castings
- Incredible grip and dexterity on wet and dry surfaces
- Lightweight nylon shell provides a nice snug fit
- CE rated for abrasion, blade cut, tear and puncture resistance

Face Shield

Packing: 1 Order NO.: 806012

GA225



Shield Style	Shield Size (inches)
Flat	7 3/4 x 15 1/4
Shield Included	Replacement Shields
Clear	GA225-1 (with PETG) GA225-2 (with PC)

- Adjustable, cushioned head band is removable
- Face shield provides impact resistance
- Includes visor (GA225-1) with PETG (impact resistance preferred)
- Optional visor (GA225-2) with PC (high temperature resistance) is available

Ear Protector

Packing: 1 Order NO.: 806013

GA3200



Noise Reduction Rating, dB	Headband
28	Cushioned
Ear Piece	Weight (lbs.)
Cushioned	0.77

- Noise reduction rating of 28 dB for protection
- Lightweight and comfortable with cushioned headband
- Cushioned ear piece for a comfortable and snug fit that keeps out noise
- Each ear piece pivots to provide a comfortable and secure fit
- Blue hard protective ear cups with Blue-Point® logo in white
- Each ear piece easily adjusts to fit a variety of sizes

Ear Protector, Ear Plug Style

Packing: 1 Order NO.: 806014

YA160A



Noise Reduction Rating, dB	Headband	
25	Plastic	
Ear Piece	Ear Piece Replacements	Weight (lbs.)
Foam	YA160A1	0.06

- 25 dB noise reduction rating
- Cushioned ear piece for comfort and snug fit to keep out noise
- Non-conductive
- Includes extra set of foam ear piece and reusable storage bag

Safety Glasses



Stock No.	Lens	Frame	Packing	Order No.
GLASS30R	Clear	Red	1	806016
GLASS30BK	Clear	Black	1	806015
GLASS31R	Clear	Red	1	806018
GLASS31BK	Clear	Black	1	806017

- Complies with ANZI Z87.1-2003
- Lens provide 99.9% UV protection
- Angle and length adjustable temples provide various suitable fitting
- Soft nose pad and soft temple tips provide comfort for long-time wearing
- Anti-fog lens coating with anti-scratch protection
- GLASS30BK and GLASS30R have a ventilation channel between frame and lens

Inspection Mirrors



Stock No.	Packing	Order No.
UIM125	1	807001
UIM225	1	807002
UIM325	1	807003

- **UIM125 Telescoping Inspection Mirror**
- 1 1/4" diameter mirror. 6 1/2" long, and extends to 35"
- **UIM225 Telescoping Inspection Mirror**
- 2 1/4" diameter mirror. 6 1/2" long, and extends to 35"
- **UIM325 Telescoping Inspection Mirror**
- 3 1/4" diameter mirror. 6 1/2" long, and extends to 29 1/2"

Pick Up Tool

Packing: 1 Order NO.: 807004

PHT5



- Lifts 2.5 lbs.
- Chrome plated shaft extends from 5 1/2" to 25 1/2"
- Black cushion grip will not slip in oily or wet hands
- Includes pocket clip
- Hinged head magnetic pick up tools
- Powerful magnets are fitted into the brass sleeve
- Adjustable hinged heads

Pick Up Tool

Packing: 1 Order NO.: 807005

PT5C



- This 5 7/8" tool extends to 25 9/16"
- Magnet lifts up to 2 lbs.
- Includes pocket clip
- Chrome
- Hinged head magnetic pick up tools
- Powerful magnets are fitted into the brass sleeve
- Adjustable hinged heads

Pick Up Tool

Packing: 1 Order NO.: 807006

PT5CBL



- This 5 7/8" tool extends to 25 9/16"
- Magnet lifts up to 2 lbs.
- Includes pocket clip
- Blue
- Hinged head magnetic pick up tools
- Powerful magnets are fitted into the brass sleeve
- Adjustable hinged heads

Pick Up Tool
Packing: 1 Order NO.: 807007

UPT15



- Lifts 2 lbs.
- 6 5/8" long, and extends to 33 1/4"
- Hinged head magnetic pick up tools
- Powerful magnets are fitted into the brass sleeve
- Adjustable hinged heads

Pick Up Tool
Packing: 1 Order NO.: 807008

UPT2FL



- 29" aluminum shaft can be easily bent at any angle to retrieve dropped metal objects in hard to reach areas
- Power cap slides over the magnet and shield its sides from attaching to unwanted metal surfaces
- Will pick up 5 lbs. with the power cap
- Textured cushion pistol grip will not slip in wet or oily hands

Pick Up Tool
Packing: 1 Order NO.: 807009

UPT35



- Lifts 4 1/2 lbs.
- 6 5/8" long, and extends to 33 1/4"
- Hinged head magnetic pick up tools
- Powerful magnets are fitted into the brass sleeve
- Adjustable hinged heads

Pick Up Tool
Packing: 1 Order NO.: 807010

UPT50A



- Lifts 10 lbs.
- 6 5/8" long, and extends to 33 1/4"
- Hinged head magnetic pick up tools
- Powerful magnets are fitted into the brass sleeve
- Adjustable hinged heads

Pick Up Tool
Packing: 1 Order NO.: 807011

UPT65



- Perfect for retrieval of heavy ferrous objects in hard to reach areas
- Goblet shaped magnetic head pushes the flux to the front of the magnet enabling the user to lift 16 lbs
- Head shields the sides of the magnet from attaching to unwanted ferrous surfaces
- Telescopes from 9" to 34 1/4" (229 to 870mm)
- Stainless steel handle is strong, lightweight and inhibits corrosion
- Cushion textured pistol grip will not slip in wet or oily hands

Hose Nozzle
Packing: 1 Order NO.: 807014

NOZZLE360A



- Turns any standard 5/8" hose into a multi-function cleaning tool
- Five different spray patterns for multiple applications
- Wash/rinse vehicles or water plants using a softer, cascading stream
- Clean pools, deck and driveways with heavy duty stream
- Clean service bays, shop floors and blast mud/dirt from vehicles with a powerful jet stream
- 360° jetted nozzle is engineered from rugged extruded aluminum, forged stainless steel, high grade fiberglass and comfort grip santoprene rubber
- Patented 2-way shut off

Pick Up Tool

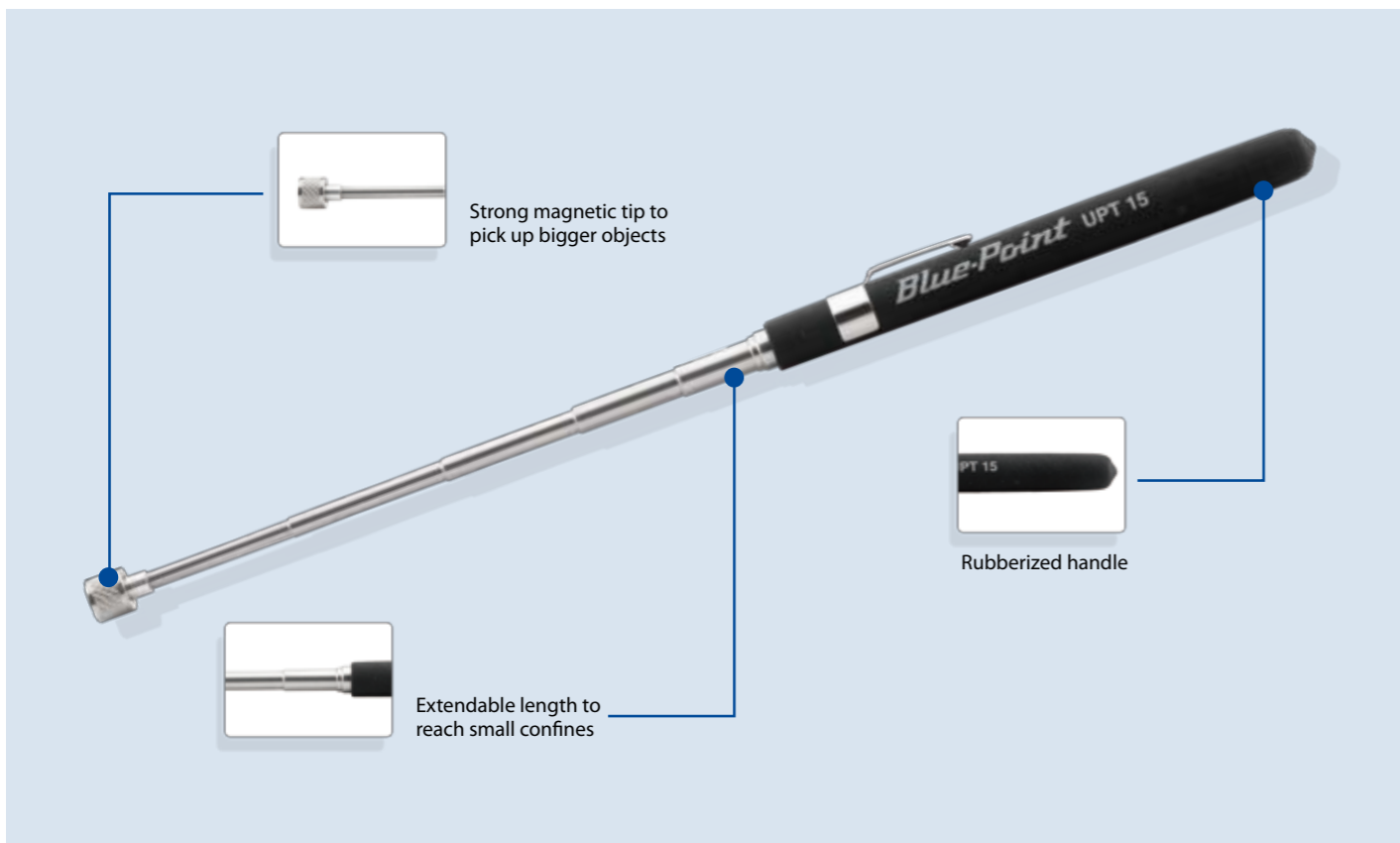

Rivet Tool
Packing: 1 Order NO.: 807012

HP2



- Has four nose pieces for 3/32" to 3/16" diameter rivets
- For 1/8" thru 5/8" thickness
- Made of aluminum alloy

Deburring Tool
Packing: 1 Order NO.: 807013

DEBUR300



- Easily deburr drilled and machined holes
- Push button locking collet enables quick, easy blade changes
- Includes three round head deburring blades
- Blades conveniently store in handle of tool
- Weighs 1 lb
- 6" long

Magnetic Holder
Packing: 1 Order NO.: 807016

CM6416



- Magnet has "on/off" switch
- Base is 2 3/8" x 1 7/8" x 2 1/2"
- Post is 7" x 15/16"
- Rod is 6" x 25/64"
- Will grip flat or curved metal surfaces

Deluxe Air Vacuum System

Packing: 1 Order NO.: 807015

AV1000A



Stock No.	Air Consumption, Average, DFM (SCFM) [l/min]	Sound Level, Free Speed, dBA
AV1000A	3 (21) [84.95]	81.2
Sound Level, Working (dBA)	Recommended Hose Size (inches)	Length (without bag), inches (mm)
81.2	3/8	13 (330)
Brush Size, inches (mm)	Bag Size, inches (mm)	Weight, lbs. (kg)
1 1/8 x 2 5/8 (28.5 x 66.7)	6 1/2 x 11 1/4 (165 x 285)	0.88 (0.4)

- Ideal for vehicle media installation and body shops plus other applications in need of picking up dust, metal shavings or broken glass
- Large collection bag includes a debris baffle and sliding bag clamp for emptying debris
- Lightweight ergonomic handle design
- Includes 8.7" aluminum extension tube, 8 1/2" plastic extension tube (AV1000A10), flexible extension tube (AV1000A9), pointed nozzle (AV1000A11) and crevice tool with brush (AV1000A8)

Bench Vise

Packing: 1 Order NO.: 807017



Stock No.	Jaw Width	Packing	Order No.
BLPMV4	4" jaws	1	807017
BLPMV5	5" jaws	1	807018
BLPMV6	6" jaws	1	807019

- Single piece steel blocks for higher load capacity
- Extended anvil
- Lubrication points for maintenance
- Optional swivel base
- Capacity range from 3.5 ton to 9 ton at maximum opening
- Reinforced cantilever support
- Interchangeable jaws
- Diamond ground for better grip
- Heavy duty cast iron construction
- Precise jaw alignment
- Rolled thread spindle for easy locating and tightening parts
- Protected spindle

C-Clamps

Packing: 1 Order NO.: 807030



Stock No.	Capacity (inches)	Throat Depth (inches)	Packing	Order No.
CL404VIS	0-4 1/2	3 1/4	1	807027
CL406VIS	0-6 1/16	3 5/8	1	807028
CL408VIS	0-8 1/4	5	1	807029

- Similar to CL series c-clamps
- High visibility models conform to OSHA safety color standard for physical hazards regulation #19110.144
- 3/4" spindle diameter

Welders Gloves

Packing: 1 Order NO.: 807030

YA427B



- Helps protect hands from sparks when welding
- Leather construction with added insulation for heat protection
- Reinforced palm for durability

Tig Welding Gloves

Packing: 1 Order NO.: 807032

YA4282



- Ideal for TIG welding processes
- Pigskin material for precise control
- Helps protect hands from heat and sparks
- Thick leather cuff for wrist protection

Welding Sleeves 1 Pair

Packing: 1 Order NO.: 807031

YA4280



- **Welding Sleeves**
- Helps protect arms from sparks when welding or cutting
- Elastic bands at each end of sleeve
- Constructed of flame retardant fabric
- 18" long
- 1 pair

Welding Helmet, Auto Darkening

Packing: 1 Order NO.: 807033

YA4603



- Two arc sensors for enhanced lens triggering
 - Fixed shade #10
 - Clear shade of 3.5
 - Fixed delay
 - Viewing area 1.38" x 3.81"
 - Solar powered
- Fixed shade auto darkening welding helmet has a lens that is designed for carbon arc welding processes. Two arc sensors provide a range of sensitivity to trigger the lens under most welding conditions. Meets ANSI Z87.1-2003, CE, DIN 4647 PZ, EN379, EN175, CSA Z 94.3 and AS/NZS 1338.1 standards

Standard Duty Welding Kit

Packing: 1 Order NO.: 807034

WE200A



- Use for Auto Repair, Construction, Fabrication, Manufacturing and Maintenance
- Cuts up to 1" and welds up to 1/8"
- Cuts up to 4" and welds up to 1/2" with optional tips
- Forged brass regulator- Durable and strong
- Regulator diameter 2 1/4- Allows precise control of gas
- Internal filter- Keeps particles from entering regulator
- PTFE Teflon sea- Positive sealing
- Handle shut off valve color coding- Ease in identifying the corresponding gas control
- Two piece cutting tip- Easier to clean
- High quality hose- Offers reduced tear resistance and increased flexibility

Stock No.	Description
HRC1401340	85 Weld Handle with Check Valves
HRC1300380	72-3 Cut Attach
HRC9100614	D-85 Weld Mixer
HRC4300557	3/16 x 20 Twin Hose
HRC4304482	Cover Goggle
HRC9004486	Striker
WE200A1	Oxygen Regulator
WE200A2	Acetylene Regulator
HRC1502172	6290-1 #1 AC Cut Tip
HRC1600890	23-A-90-5 #5 Weld Tip
HRC1600870	23-A-90-3 #3 Weld Tip
HRC1600850	23-A-90-1 #1 Weld Tip

Stock No.	Description
HRC1800710	J-63-1 Heating Assembly
HRC1600840	23-A-90-0 #0 Weld Tip
HRC1600860	23-A-90-2 #2 Weld Tip
HRC1600880	23-A-90-4 #4 Weld Tip
HRC1502170	6290-00AC #00AC Cut Tip
HRC1502171	6290-0AC #0AC Cut Tip
HRC1502173	6290-2AC #2AC Cut Tip
HRC1502174	6290-3AC #3AC Cut Tip
HRC4301650	88-5FBT PR. Torch Flash Arrestor
HRC9000160	E-9 Tip Cleaner (2 pc tip)
HRC9004484	Replacement Flints

Optional Accessories



Shop & Technician Tools



Our shop and technician tools focus mainly on the automotive industry with commonly used items like multimeters and protective gloves, to equipment and devices specially made for vehicle engine code reading and valve servicing. We have almost a tool to cater for all job tasks commonly done in the automotive industry.

Testing and Electronics	126
Special Tools	128
Automotive Specialty Tools	131

Borescope (Available from July, 2011)

Packing: 1 Order NO.: 901008

BKB5400



- **Simple to use:**
 - Ø8.5mm imager head fits into most spark plug holes
 - 36" (914 mm) long flexible shaft
 - High intensity LED's provide direct light where it is needed
 - 0.75" (19.05 mm) Flexible Shaft Minimum Bend Radius
 - Obedient Shaft
 - Single On / Off Button
 - Battery Indicator-4 AA Alkaline cells
 - Thumb control of the LED intensity
 - 8 increment LED control
 - Durable Tool Housing for durability
 - Collapsible Hook, and Stand for hands free use
 - Analog video out port with cable
- **Excellent Image Quality**
 - 320 x 240 Imager Resolution
 - 320 x 240 Screen Resolution
 - 2.45" (62.23 mm) Color LCD
 - Optimal Focal Length of 0.5" (12.7mm) to 12" (304.8mm)
- **Accessories**
 - 90° glass mirror attachment for viewing to the side
 - Magnet attachment to retrieve parts and tools

Borescope (Available from July, 2011)

Packing: 1 Order NO.: 901009

BKB6000



- **Simple to use:**
 - Ø5.5mm imager head fits into most spark plug holes and diesel injector ports
 - 36" (914 mm) long flexible shaft
 - High intensity LED provide direct light where it is needed
 - Big 3.5" (88.9mm) Color LCD screen
 - Easy to use interface
 - 4 AA Alkaline cells
 - Detachable handle for greater control
 - Fine Adjustment of LED intensity
 - Capture Still Pictures at 640 x 480 resolution
 - Capture Video at 640 x 480 resolution, 15 fps
 - Save pictures and videos to the units memory
 - Send pictures and videos to customer and colleagues via email
 - Quality Tool Housing for durability
 - Collapsible Hook, and Stand for hands free use
 - Analog video-out port
- **Excellent Image Quality**
 - 320 x 240 Imager Resolution
 - 320 x 240 Screen Resolution
 - 3.5" (88.9mm) Color LCD
 - Optimal Focal Length of 0.5" (12.7mm) to 12" (304.8mm)
- **Accessories**
 - 90° glass mirror attachment for viewing to the side
 - Magnet attachment to retrieve parts and tools

Borescope



- **Optimal focal length of 1/2 inch**
- **High intensity LED light**

Pick Sets



Stock No.	Description	Length (inches)	Packing	Order No.
PSLR4-1	Hook Pick	9 ³ / ₄	1	901011
PSLR4-2	90° Hook Pick	9 ³ / ₄	1	901012
PSLR4-3	Straight Pick	9 ³ / ₄	1	901013
PSLR4-4	Complex Pick	9 ³ / ₄	1	901014
PSLR4-5	Combo Pick	9 ³ / ₄	1	901015
PSLR4-6	Double Angle Pick	9 ³ / ₄	1	901016

- **PSLR4** (Order No.901010) extra long pick set includes PSLR4-1 thru PSLR4-4 (4 pcs) in vinyl storage pouch
- **PSLR6** (Order No.901001) extra long pick set includes PSLR4-1 thru PSLR4-6 (6 pcs) in vinyl storage pouch

Wire Cutter

Packing: 1 Order NO.: 901005

PWC27



Description	Length (inches)	Strips AWG Sizes
Automatic Wire Stripper	6 ³ / ₄	10, 12, 14, 16, 18, 20, 22
Strips Metric Sizes, (mm)	Application	Replacement Blades
—	Strips PVC, THHN, and THWN	PWC27-7

- One-step stripping enhances productivity
- Spring-action motion increases leverage and reduces operator fatigue
- Precision ground, knife-type blades provide clean, accurate stripping
- Cleanly strips wire up to full 7/8" (22mm)

Tweezer Kits, 5 pcs

Packing: 1 Order NO.: 901006

TZK5



- Includes five tweezers neatly arranged in a vinyl zipper pouch
- All stainless steel construction
- Pointed tweezers w/plain ends, 4 3/8" long
- Self closing tweezers w/plain ends, 4 1/2" long
- Sharp point utility tweezers w/bent plain ends, 7" long
- Sharp point utility tweezers w/plain ends, 7" long

Tweezer Kits, 7 pcs

Packing: 1 Order NO.: 901007

TZK7



- Includes seven tweezers neatly arranged in a black vinyl zipper pouch
- All stainless steel construction
- Pointed tweezers, 4 3/8" long
- Curved head utility tweezers, 6 3/4" long
- Sharp pointed utility tweezers, 7" long
- Side locking tweezers, 6" long
- Spade point tweezers, 4 3/8" long
- Weighted solder tweezers, 6" long

Wire Stripper

Packing: 1 Order NO.: 901004

PWC6



Description	Length (inches)	Strips AWG Sizes
Wire Stripper/Cutter/Pliers	6	10, 12, 14, 16, 18, 20
Strips Metric Sizes (mm)	Application	Replacement Blades
2.6, 2.0, 1.6, 1.3, 1.0, 0.80	Strips PVC, THHN, and THWN	—

Wire Stripper

Packing: 1 Order NO.: 901002

PWC12A



Description	Length (inches)	Strips AWG Sizes
Wire Stripper/Cutter/Crimper	9 ¹ / ₂	10, 12, 14, 16, 18
Strips Metric Sizes (mm)	Application	Replacement Blades
10-18 Insulated and Non-Insulated 7-8mm Ignition Terminals	—	—

Wire Stripper

Packing: 1 Order NO.: 901003

PWC14



Description	Length (inches)	Strips AWG Sizes
Wire Stripper/Cutter/Crimper/Bolt Cutter	8 ³ / ₄	10, 12, 14, 16, 18, 20, 22
Strips Metric Sizes (mm)	Application	Replacement Blades
10-22 Insulated and Non-Insulated 7-8mm Ignition Terminals	—	—

Wire Cutter

Packing: 1 Order NO.: 902015

PWC19



Description	Length (inches)	Strips AWG Sizes
Micro Shear Wire Cutters	5 1/8	Up to 20
Strips Metric Sizes, (mm)	Application	Replacement Blades
Up to .80	—	—

- Micro shear wire cutters

Power Bit Set, 52 Pcs

Packing: 1 Order NO.: 902005

YA52PBSQC



- Ideal for use with cordless drills and screwdrivers
- Includes:
 - 49 1/4" hex shank bits in short and long lengths
 - 2 hex adaptors
 - Flat tip bits (long): 6-8, 8-10, 10-12
 - Hex bits (short): 1/8", 9/64", 5/32", 3/16", 7/32", 1/4", 9/32"
 - Hex bits (long): 5/32", 3/16", 7/32"
 - PHILLIPS® tip bits (short): #1, #2 (2 each), #3
 - PHILLIPS® tip bits (long): #1, #2, #3
 - TORX® tamper resistant bits (short and long): T10, T15, T20, T25, T27, T30, T40
 - Square bits (short and long): #1, #2, #3
 - Clutch bits (short and long): 5/32", 3/16"
 - Double end bits: 6-8 x #2 PHILLIPS®, 8-10 x #3 PHILLIPS®
 - Adaptors: 1/4" hex female to 1/4" hex female, 1/4" hex male to 1/4" square male, 1/4" hex quick change chuck

Crimp Tool

Packing: 1 Order NO.: 902013

PWC34



- Double compound action with ratchet control for almost effortless operation
- Use with insulated connectors on 10 to 22 gauge wire
- For easy, efficient, single squeeze crimping of modular connectors
- Both primary and secondary crimps are made simultaneously to factory specifications
- Has a comfortable ergonomic design and full cycle ratchet action

Pinch Bars

Stock No.	Sq. Stock (inches)	Edge (inches)	Length (inches)	Order No.
1412A	1/2	5/8	14	902006
1658C	1/2	5/8	16	902010
2420A	3/4	15/16	20	902011
2430C	3/4	5/8	30	902012
2438C	3/4	7/8	38	902007
2842C	7/8	1	42	902008



Magnetic tray

Packing: 1 Order NO.: 902001

YA105020



New

Stock No.	Description	Sizes	Packing	Order No.
MRB5A	Magnetic tray, Round	Round 152mm diameter	1	902018
MRB10A	Magnetic tray	250mm x 140mm	1	902019
MRB12A	Magnetic tray	355mm x 140mm	1	902020
MRB15A	Magnetic tray	290mm x 265mm	1	902021

- Securely holds small parts and tools
- Magnetically attaches to any flat iron or steel surface
- Material: 430 Stainless Iron

Blow Gun

Packing: 1 Order NO.: 902001

YA105020



- 20" bent nozzle
- Trigger provides variable air flow control
- Lightweight body with ergonomically designed grip provides comfort and control
- Insulated handle prevents cold hands
- Venturi tip directs air sideways if tip end is obstructed
- Reinforced 1/4"-18NPT inlet
- Maximum air pressure: 232 PSI (16 BAR)

Blow Gun

Packing: 1 Order NO.: 902002

YA1055B



- Variable flow trigger offers precise air flow control
- Six-outlet "star tip" delivers an even distribution of air
- 4" Full Flow tube
- Ergonomic handle design for increased comfort
- Complies with OSHA safety standards
- Air Inlet: 1/4" NPT
- Maximum Working Pressure: 175 PSI (12 bar)
- Vented Tip
- Triggers regulate airflow from partial to full line pressure
- Valve has no cutoff and no restrictions
- Each tip is side vented
- Each gun includes hanging hook and paddle-type air control lever

Wire Stripper

Packing: 1 Order NO.: 902016

PWC28A



Description	Length (inches)	Strips AWG Sizes
Wire Stripper/Cutter/Crimper/Bolt Cutter	8 1/4	10, 12, 14, 16, 18, 20, 22 Stranded, 8, 10, 12, 14, 16, 18 Solid
Strips Metric Sizes, (mm)	Application	Replacement Blades
10-22 Non-Insulated Terminals and Crimp Sleeves	—	—

- One-step stripping enhances productivity
- Spring-action motion increases leverage and reduces operator fatigue
- Precision ground, knife-type blades provide clean, accurate stripping
- Cleanly strips wire up to full 7/8" (22mm)

Torx Ball Hex Bit Set, 11pcs

Packing: 1 Order NO.: 902004

SDM11KT



- 1/4" shank bits for use in difficult access applications where fastener cannot be approached straight-on
- 11 pc. set includes:
 - TORX® Ball Hex Bits: T10, T15, T20, T25, T27, T30, T40, T45, T50
 - Magnetic Insert Bit Holder
 - 1/4" Female Hex to 1/4" Female Sq. Dr. Adaptor
- All components store in case with belt clip

Master Ball Hex Bit Set, 32pcs

Packing: 1 Order NO.: 902003

SDM32KT



- 1/4" shank bits for use in difficult access applications where fastener cannot be approached straight-on
- 32 pc. set includes:
 - Fractional Ball Hex Bits: 3/32", 7/64", 1/8", 9/64", 5/32", 3/16", 7/32", 1/4", 5/16", 3/8"
 - Metric Ball Hex Bits: 2, 2.5, 3, 4, 5, 6, 7, 8, 9, 10mm
 - TORX® Ball Hex Bits: T10, T15, T20, T25, T27, T30, T40, T45, T50, T55
 - Magnetic Insert Bit Holder
 - 1/4" Female Hex to 1/4" Female Sq. Dr. Adaptor
- All components store in case with belt clip

Gauge Set

Packing: 1 Order NO.: 903027

FBS5



- 5 piece set includes FB300A Bent Blade Feeler Gauge, FB305A Non-magnetic Feeler Gauge, and FB325A General Use Feeler Gauge, plus GA461B and FB360B Spark Plug Gap Gauges in the FBS5-1 Kit Bag

Digital Drum Gage

Packing: 1 Order NO.: 903029

DG530



- Measures automotive and heavy duty brake drums
- Pointed anvils and 4.25" long arms allow increased measurement accuracy and coverage
- Easy to read digital display with inch/metric conversion
- Selectable depth stops for easier use
- Range 6"-20.65"/150mm-515mm
- Graduations .0005"/.01mm

Pad Spreader

Packing: 1 Order NO.: 903128

YA2440



- For use on most domestic and import cars and light duty trucks with single piston disc brakes without parking brakes
- Compresses the disc brake piston for easy pad installation

Prybar Set

Packing: 1 Order NO.: 902009

BLPPB704



- Set includes 1412A (14") and 2420A (20") pinch bars, 7031A close quarter bar (16") and BPPC1878 flat chisel (18")
- All bars have a 100% black oxide finish

Cable Cutter

Packing: 1 Order NO.: 902014

PWC80A



- For cutting battery cables and other soft metal cables
- Has red, vinyl covered handles
- 7 1/2" long

Bender, Tubing

Packing: 1 Order NO.: 902017

TBS200A



- Makes left, right, or offset bends up to a 90° angle
- Degrees shown for accurate bending angle
- Handles 3/16", 1/4", 5/16", and 3/8" (4, 6, and 8mm) OD aluminum, copper, and stainless steel tubing
- Aluminum unit is 8 1/4" long when opened

Brake Rotor Tool

Packing: 1 Order NO.: 903031

YA9329A



- Use to rotate piston back into caliper cylinder when replacing pads
- Also rotates parking brake cylinder back into the caliper cylinder on vehicles with four wheel disc brakes
- For 1975 and later Ford and Mercury plus some imports

Spreader

Packing: 1 Order NO.: 903129

GA395



- For standard four piston caliper disc brakes
- Frees hands to assemble caliper over rotor
- 6 3/4" long

4 Ton Portaset

Packing: 1 Order NO.: 903132

YA1544A



- 4-ton capacity kit includes hydraulic unit, five "Snap-Set" extensions, spreader plus a full selection of attachments for most push applications
- Automatic pump overload system protects against damage to rams and equipment
- 1/2-ton capacity hydraulic spreader has 2" jaw and spreads from 5/8" to 3 3/4"
- Flex head includes permanently molded rubber pad
- Heavy walled extensions tubes stand up to the toughest loads
- Long handle reduces required pumping effort
- 18 piece set is stored in durable storage case

Tap & Die Set

Packing: 1 Order NO.: 903037

GA541



- Taps and dies from 1/4" to 1/2" in both NF and NC threads, taps and dies from 4-40 thru 12-24 and corresponding dies in Machine Screw Threads, a pipe thread tap and die, plus two die stocks and three tap wrenches, a screw pitch gauge, and a die adjusting screwdriver (41 pcs) in a storage case
- Die size 1/4" to 1/2" and 7 mm to 12 mm are a one-piece, 12-point design that can be turned with a 1" socket wrench (5/8" socket wrench for 3 to 6 mm dies) when working in places where a normal die stock cannot be used

Metric Tap & Die Set

Packing: 1 Order NO.: 903038

GAM541



- 40-pc set features 1" single hex non-adjustable dies from 3 to 12mm, a 1/8"-28 BSP die plus taps in the same sizes
- Also includes a die stock, 2 T-handle tap wrenches, a thread pitch gauge, a drill/tap chart and a midget screwdriver, all in a storage case

Extractor Set

Packing: 1 Order NO.: 903040

E1020



- Extracts broken screws from 1/4" to 1/2" diameter
- Comes in a storage case

Exhaust Hanger Remove Pliers

Packing: 1 Order NO.: 903034

YA3202



- For removing hanger brackets from their rubber mounting straps
- Place removal jaw behind the rubber grommet ring and the forcing pin of the pliers on the end of the steel hanger
- When handles are squeezed, the forcing pin pushes the ring off the hanger
- Applications on most domestic and import cars as well as light trucks
- 14" long

Boot Pliers

Packing: 1 Order NO.: 903036

YA824C



- 45° offset jaws
- Vinyl coated jaws and handles assure gripping ability
- Use only on automotive type ignition systems 9 1/2" long

Boot Pliers

Packing: 1 Order NO.: 903035

YA824ASTR



- Straight jaw version of YA824C
- 9 3/4" long

Extractor Set

Packing: 1 Order NO.: 903039

E1025



- Extract broken screws from 1/4" to 1" diameter and standard pipe sizes 1/8" to 1"
- Packaged in a storage case

Meter ATV And Motorcycle

Packing: 1 Order NO.: 903041

MTPV1000



- Peak voltage measurement of secondary ignition systems on all types of vehicles and pleasure craft
- CDI ignition diagnosis on motorcycles, ATVs, and snowmobiles
- Digital Multimeter functions to measure battery, sensor and circuit voltage
- Check continuity of wiring and resistance of ignition wires

Circuit Tester

Packing: 1 Order NO.: 903151

BPECT1



- Circuit tester for 6 and 12 volt systems.
- Quickly and safely tests high and low voltages on all vehicles including computerized engine.
- Can be used to detect power, ground and find shorts and breaks.
- High impedance to protect sensitive electronic sensors, microprocessors, electronic ignition components and air bags.
- LED indicates red for power (high) and green for ground (low).
- Insulated alligator clip.

Fuse Buddy Pro Test Kit

Packing: 1 Order NO.: 903044

EEFB310



- Great tool for reading circuit amperage draws and troubleshooting up to 30 amps
- Pro Kit includes one meter with 3 interchangeable test functions: 30 amp MINI circuit current testing, 30 amp ATC circuit current testing and 30 amp all purpose current test
- Plugs directly into MINI and ATC fuse sockets
- Additional 30 amp test clips expand the testing capability
- Original fuse is replaced in-line, thereby maintaining circuit protection
- Easy connection into fuse socket, Fuse Body™ end is shaped like a fuse
- LCD display features analog bar graph
- Unit also features Data Hold and Auto Power-Off
- Measuring Range: 0-30 Amps/48 VDC-10 seconds
- Accuracy: ±2% of reading
- Resolution: 100 mA

Fuse Saver Kit

Packing: 1 Order NO.: 903045

YA8005



- Dual type fuse box connector with 10' cord allows you to move around the vehicle shaking testing wires while looking for the short
- No wasted fuses
- Includes 3 resetting breaker handles: 10, 15 and 20 Amp
- Use when installing radios, CD players, radar detectors and other accessory equipment
- Includes YA8005-7, YA8005-10, YA8005-15 and YA8005-20 in YA8005-PB storage case
- YA8005-5 Fuse Handle and YA8005-EXT are optional accessories for the YA8005 Kit and are not included

Automatic Meter

Packing: 1 Order NO.: 903043

MT454C



- The MT454C is a durable, easy to use compact size digital multimeter
- Include:
- Compact size fits comfortably in the palm of your hand
- Easy-to-read 4000 count digital display
- Automatically selects the correct function of DC Volts, AC Volts or Ohms (Resistance)
- Use DC Voltage ranges to verify that the proper voltage level is arriving at a sensor or circuit
- Measure ohms to determine resistance of a coil
- Also test resistance of fuses, fusible links, components and circuits
- Measure AC voltage signals on digital MAF sensors, wheel speed sensors and vehicle speed sensors
- Protective boot with tilt stand, test leads, battery and instruction manual included
- Five year limited warranty

Meter Manual Ranging

Packing: 1 Order NO.: 903042

MT501C



- Ergonomic, compact size fits comfortably in the palm of the hand
- Measure Ohms to determine resistance of a coil or spark plug wire
- Also test continuity of fuses, fusible links, components and circuits
- Use DC voltage ranges to verify proper voltage level is arriving at a sensor or circuit
- Large, easy-to-read, 2000 count LCD display
- Lock readings on display with data hold
- Measure AC voltage signals on digital MAF sensors plus wheel and vehicle speed sensors
- Added protection against drops and the elements with included rubber boot
- Safety! cULus 3111 Listed. Meets CE and IEC 1010 safety standards
- 5 year limited warranty

Meter Autoranging

Packing: 1 Order NO.: 903002

MT574C



- The MT574C offers both automatic and manual ranging
- Measure Ohms to determine resistance of a coil or spark plug wire
- Use the diode function to test the diode pack on a typical alternator
- Use DC voltage ranges to verify proper voltage level is arriving at a sensor or circuit
- Large, easy-to-read, 4000 count LCD display with low battery indication
- Lock readings on display with data hold
- Measure AC voltage signals on digital MAF sensors plus wheel and vehicle speed sensors
- Measure DC current to determine presence of a parasitic load
- Added protection against drops and the elements with included rubber boot
- Safety! cULus 3111 Listed. Meets CE and IEC 1010 safety standards
- 5 year limited warranty

Specifications.	MT454C	MT501C	MT574C
Display Count	4,000	2,000	4,000
AC Volts	600	600	600
DC Volts	600	600	600
Basic DC Accuracy	0.50%	0.75%	0.30%
AC Amps	—	—	400mA
DC Amps	—	—	400mA
Resistance	40M Ohm	2K Ohm	40M Ohm
Auto Range	Yes	—	Yes
Data Hold	—	Yes	Yes
Min/Max	—	—	Yes
Auto Power Off	Yes	—	Yes
CE or UL Listed	CE, cULus 3111	CE, cULus 3111	CE, cULus 3111
CAT Rating	CATIII 600 Volt	CATIII 600 Volt	CATIII 600 Volt

Max Fuse Buddy®

Packing: 1 Order NO.: 903046

EEFB315



- MAXI circuit testing capability up to 80 Amps
- Also works with ATC and mini circuits-includes adapters
- Large LCD display with analog bar graph
- Unit features peak hold functions
- One touch zero function
- Amps: 0-80 Amps DC
- Resolution: 0.1A
- Accuracy: +2.0% of reading + 4 digits
- Power by: 9 volt Battery

5 Pin Trailer Light Tester

Packing: 1 Order NO.: 903047

TLT5



- Easily locates electrical problems in the tow vehicle
- Checks both 4 and 5 pin flat trailer connectors with LED indicator lights
- Tests left and right signals, brake lights and running lights
- Unique and durable design allows user to leave the tester in line to continuously monitor the lighting system on the tow vehicle

6 Pin Trailer Light Tester

Packing: 1 Order NO.: 903048

TLT6



- Easily locates electrical problems in the tow vehicle
- Checks 6 pin round trailer connectors with LED indicator lights
- Tests left and right signals, brake lights and running lights

Trailer Circuit

Packing: 1 Order NO.: 903049

TLT7



- Easily locates electrical problems in the tow vehicle
- Checks 7 pin round trailer connectors with LED indicator lights
- Tests left and right signals, brake lights and running lights
- Applications include newer light trucks and SUV's

3 Way Trailer Adaptor

Packing: 1 Order NO.: 903050

TLT8000



- Applications include medium/light duty trucks, 1/2 ton, 3/4 ton and 1 ton pickups, campers, and other heavy duty applications
- Adapts 7 way connection to 6 round pin and 4/5 pin connections
- Sealed plugs to keep road debris from corroding connections
- One adaptor for all your trailer needs
- Made from strong nylon 6
- Winged grip for easy installation and removal

Dual 12V Trailer Plug Adaptor

Packing: 1 Order NO.: 903051

TLT8003



- Converts 12 volt feed at the back of a truck or SUV trailer socket and to a dual 12 volt power outlet
- Powers 12 volt test equipment, charging equipment and work lights in shop environment
- Recreation purposes such as running air pumps, radios or TV's while tailgating and camping
- Dual 12 volt power supply sockets
- Plugs into any 7-way spade pin trailer connection
- Use as 12 volt feed for diagnostic equipment
- Convenient power source for accessory plug-ins
- Both shop and recreational uses
- Includes dust cover to help prevent corrosion

Professional Timing Light

Packing: 1 Order NO.: 903056

EETL5568



- Multi function timing light works on all distributorless and conventional ignition systems
- Patented skip circuitry tests tachometer readings up to 9,900 RPM
- View, set and adjust ignition advance and retard: 0° to 90°
- Measure and adjust ignition dwell: 0° to 180°/ 2-12 cylinders
- Measure battery and charging voltage: 10 to 16 volts
- Dual display backlit screen allows clear viewing of tachometer and ignition advance reading
- Pivoting barrel allows easy access and a clear view to ignition timing marks
- One hand operation with protective hand guard for comfort and safety
- Clearly view each flash at all RPM's with patented skip circuitry
- Serviceable heavy duty leads and metal inductive pickup
- Shock resistance rubber boots for added durability
- Bright high intensity flash
- Includes EETL5568-PB storage case

Gas Cap Adaptor

Packing: 1 Order NO.: 903053

EELDGCAP1



- Quickly pops-on virtually any filler neck
- Costly replacement seals are no longer needed
- One size fits all (new model vehicles may be subject to change)

Universal EFI Quick Probe

Packing: 1 Order NO.: 903058

YA76462



- Quickly detects electronic fuel injector functions on any gas or diesel engine
- Specifically designed to detect the vibrations emitted when the electronic injector fires
- No hunting for injector wires to test at the connector
- No need to remove the injector for testing
- Super bright LED strobe
- 7" removable probe tip
- Battery operation
- Sensitivity thumb wheel

Terminal Tool Kit

Packing: 1 Order NO.: 903057

TT12KT



- Applications include most GM and other domestic computer connectors and terminals. Individual handles for easy access in tight places. Designed for weather pack and pack-con terminals with flat blade to open connectors and fork for ALDL connectors to access trouble codes. Color coded: Red handle for GM and Green for wire terminal tools. Includes storage case
- Kit includes these GM C3 System Terminal Tools (red handle):
 - Tube, Spring Loaded, 3.3mm x 28mm
 - Square Blade, 1.4 x 19.00mm
 - Flat Blade, 1.5 x 24.75mm
 - Flat Blade, 2.0 x 23.00mm
 - Fork Blade, 8.0 x 24.00mm
 - Flat Blade Screwdriver, 3/16" x 1.00"
- Kit includes these Wire Terminal Tools (green handle):
 - Tube, 3.30 x 28.0mm
 - Tube, 4.30 x 13.0mm
 - Tube, 3.75 x 13.0mm
 - Tube, 3.00 x 13.0mm
 - Flat Twin Blade, 3.0mm
 - Flat Twin Blade, 1.6mm

Mini Engine Electronic Stethoscope

Packing: 1 Order NO.: 903054

YA6910



- Sensor clamp helps to detect noises during test drives that can not be duplicated in the work bay
- Sensor tip mounted on 6" flexible shaft allows access to hard-to-reach areas
- 5" inductive metal probe allows user to pinpoint source of noise or vibration
- Ultra sensitive microphone provides a full range of sound
- Rotary volume control allows easy adjustment
- Ear-bud style earphones provide excellent sound quality

Infrared Thermometer

Packing: 1 Order NO.: 903055

RTEMPB3A



- Temperature range of -58° to 932°F (-20°C to 500°C)
- Use for most automotive and industrial applications requiring an infrared thermometer
- Compact size of 5.88" x 3.62" x 1.38" (149.2 x 92.1 x 34.9mm)
- Laser targeting accuracy
- Enhanced backlit 4 digit LCD for easy viewing
- Automatic power-off after 10 seconds
- Nylon holster for transport and safe storage
- Safely monitor hot, hazardous, or hard to reach materials without contamination or damage to the surface
- Simply point at target, pull the trigger, and read the temperature on the large, backlit LCD display

Probe, Coil-On-Plug

Packing: 1 Order NO.: 903052

YA76562



- Super bright KV & ARC indicator LEDs
- 7" signal receiver probe
- Battery operated
- Sensitivity thumb-wheel

Line Clamp Set

Packing: 1 Order NO.: 903005

HCP3KT



- HCP6A, HCP7A and HCP10A (6", 7", 10") in storage pouch
- **HCP6A Hose Pinching Pliers**
 - For sealing hose sizes 1/8" to 5/16"
 - Also use on brake lines, fuel lines and vacuum hoses
 - 6" long
- **HCP7A Hose Pinching Pliers**
 - For sealing hose sizes 1/2" to 3/4"
 - Also use on heater hoses and vacuum lines
 - 7" long
- **HCP10A Hose Pinching Pliers**
 - For sealing hose sizes 3/4" to 2 1/4"
 - Also use on radiator hoses
 - 10" long

Battery Maintainer

Packing: 1 Order NO.: 903060

EEBM100



- Fully automatic 12 volt operation, 1.5A charging rate
- Compatible with conventional, maintenance free, AGM, gel cell spiral wound and deep cycle batteries
- LED charging status indication
- Rubberized boot to avoid scratching vehicle components and to protect the maintainer
- Quick connect output cord with clamp set and ring terminal output accessories

Master Line Disconnect Set

Packing: 1 Order NO.: 903059

LDT8



- A complete set of disconnect tools for spring lock and quick disconnect couplings used on air conditioning and fuel lines on Ford, GM and Chrysler vehicles
- Includes a set of six standard disconnect tools (5/16", 3/8", 1/2", 5/8", 3/4" and 7/8") and six color coded, angled disconnect tools for use in tight spots
- **SPECIALIZED GM APPLICATIONS:** Includes tools for use on GM 3/8" flex fuel capable fuel filter removal plus 5/16" and 3/8" GM fuel modules
- **SPECIALIZED FORD APPLICATIONS:** Includes tools for use on 3/8" and 1/2" Ford transmission and cooler lines with stepped line plus 5/16" x 3/8" scissor disconnect and Ford coupler disconnect tools

Master Plus Disconnect Set

Packing: 1 Order NO.: 903006

LDT14



- LDT14 contains all tools from the popular LDT8, Master Disconnect Set; in addition the kit has:
- The two most popular Jiffy-tite Disconnect tools
- The new blue 5/16" fuel line adapter
- A set of 4 air line push-pull disconnect tools that work on heavy duty trucks and industrial applications
- Label inside cover of carrying case shows images and applications

Battery Carrier

Packing: 1 Order NO.: 903064

BL1B



- For top post and side terminal batteries
- Rubber pads securely grip battery widths from 5" to 7"
- Plastic hand grip provides a firm hold

Manifold Repair Kit

Packing: 1 Order NO.: 903065

ACT1234PKT



- Includes various replacement lens, knobs,
- O-rings, gaskets and more
- Kit components are used to service ACTR41511

Battery System Tester

Packing: 1 Order NO.: 903061

YA2612B



- No conversion tables needed for CCA, SAE, IEC, EN, or Ah
- Battery condition is shown in % of capacity
- Uses conductance technology
- Tests 12V starting/charging systems
- Tests both flooded lead acid and AGM batteries
- Multi-colored bar graph displays battery condition
- Low voltage indicator LED lights when charging is necessary
- Bad cell is detected and displayed
- Comfortable grip with easy to use clamps
- Tests discharged batteries
- Patented circuitry
- Reverse polarity protection
- Made in USA

Terminal Brush

Packing: 1 Order NO.: 903063

BTC3A



- Stiff wire bristles thoroughly clean posts and clamps
- 3 3/8" long

Manifold Set

Packing: 1 Order NO.: 903066

ACTR4131



- Anti-flutter gauges smooth out needle movement
- Easy grip all metal side mounted knobs
- Piston type free floating valves reduce O-ring wear
- Manual R134a couplers
- Gauges can be recalibrated to maintain accuracy
- 60" inner nylon layer hoses meet EPA, SAE, and UL standards
- Yellow hose includes shut off valve

UV Leak Detection Flashlight Kit

Packing: 1 Order NO.: 903068

ECFUVLITE



- High intensity LED bulb with 100,000 hour service life
- Over four hours of peak performance per charge
- Power comparable to high intensity 75 watt lamps
- Compatible with all standard leak detection dyes
- Inspection range of up to 6'
- Three "AAA" batteries and fluorescence enhancing glasses are included

Replacement Hose (R12)



Stock No.	Packing	Order No.
ACTB72	1	903069
ACTY72	1	903078

- ACTB72**
- 1/4 turn manual shutoff valves
 - Blue, 6' length
- ACTY72**
- 1/4 turn manual shutoff valves
 - Yellow, 6' length

Replacement Hose (R12)



Stock No.	Packing	Order No.
ACTB72A	1	903070
ACTY72A	1	903079

- ACTB72A**
- Automatic shutoff valves
 - Blue, 6' length
- ACTY72A**
- Automatic shutoff valves
 - Yellow, 6' length

Replacement Hose (R134a)



Stock No.	Packing	Order No.
ACTRB72	1	903072
ACTRR72	1	903074
ACTRY72	1	903076

- Low permeation hoses for internal equipment connections
- ACTRB72**
- Blue, 6' length
- ACTRR72**
- Red, 6' length
- ACTRY72**
- Yellow, 6' length

Replacement Hose (R134a)



Stock No.	Packing	Order No.
ACTRB96	1	903073
ACTRR96	1	903075
ACTRY96	1	903077

- Low permeation hoses for internal equipment connections
- ACTRB96**
- Blue, 8' length
- ACTRR96**
- Red, 8' length
- ACTRY96**
- Yellow, 8' length

Manual A/C Hose Crimper

Packing: 1 Order NO.: 903071

ACTMAN2100



- Unit is easily mounted to bench with holding fixture or held securely in a vise
- Includes a complete set of dies covering standard #6, #8, #10 and #12 hose sizes
- Includes storage case

Thermometer

Packing: 1 Order NO.: 903080

ACT73A



- Range 0° F to 220° F (-18° C to 105° C) in 2° increments
- Checks temperature of condenser, outside air, and cooling power

Dial Type Thermometer

Packing: 1 Order NO.: 903081

ACT83A



- Range 0° F to 220° F in 2° increments
- Storage case
- Stem should be immersed about 2" in liquids, 4" in gases

Pocket Digital Thermometer

Packing: 1 Order NO.: 903082

TEMP10



- Measures liquid, air and surface temperatures via sturdy stainless steel probe
- Digital display for easy viewing
- Angle viewing head can be lifted and rotated 180° for a different viewing angle
- Convertible from Fahrenheit (F) to Centigrade (C) temperature ranges
- The -58° F to 300° F (-50° C to 150° C) temperature range enables use on a wide range of applications
- Tactile on/off button for easy operator use (auto off function extends battery life)
- Tactile data hold button holds the reading when the display cannot be seen
- Temperature range noted on bevel
- Plastic carrying sheath protects the user when carried in shirt pocket

Fin Straightener & Cleaner

Packing: 1 Order NO.: 903083

ACT407



- Multi-head tool handles 8, 9, 10, 12, 14, and 15 fins per inch
- 4 1/4" long

Spanner Wrench

Packing: 1 Order NO.: 903084

ACT499A



- Adjustable three stud design for GM R-4 compressors
- Also has applications on some GM, Warner, Pitts, and Ogura clutches

Core Service Tool

Packing: 1 Order NO.: 903085

ACT81290



- Use on R12/R134a standard valve cores and JRA/EATON large bore R134a valve cores

Orifice Tube Tool

Packing: 1 Order NO.: 903086

ACT1008A



- Services A/C systems
- 6 1/4" long
- Manual shut-off valves

Expansion Tube Remover

Packing: 1 Order NO.: 903089

ACT106B



- For most GM models
- 4" long
- Manual shut-off valves

Orifice Tube Remover

Packing: 1 Order NO.: 903087

ACT1009A



- Use as CCOT and FFOT screen extractor
- Use in conjunction with ACT106B
- Manual shut-off valves

Flush Kit

Packing: 1 Order NO.: 903088

ACT1046C



- Provides pressure flushing of condensers, evaporators, and refrigerant lines after the A/C system is completely discharged
- Designed to work with any lightweight flushing material that can be mixed with pressurized air
- Includes flush gun, hose, canister, and canister adaptor

Universal Valve Core Service Tool

Packing: 1 Order NO.: 903093

ACT1290A



- Removes and replaces standard size Schrader style valve cores plus the larger size found in GM systems

Disconnect Set

Packing: 1 Order NO.: 903004

ACT1370



- Set includes six tools for disconnecting spring couplings on fuel lines
- Convenient plastic holder included
- Also useful on A/C spring couplings as well as push lock connectors on radiator and transmission lines
- Includes six tools for disconnecting spring couplings on Ford, GM, and Chrysler A/C lines
- Works on fuel lines and can be used as push lock connectors on radiator and transmission lines
- Included sizes are 5/16", 3/8", 1/2", 5/8", 3/4" and 7/8"

Leverage Hose Cutter

Packing: 1 Order NO.: 903097

PWC60



- (8 1/2") Compound action multiplies normal hand pressure to easily slice through many types of rubber and plastic hose up to 1 1/8" in diameter
- Includes stainless steel cutter blades and internal components

Oil Injector Adaptor

Packing: 1 Order NO.: 903090

ACT111B



- Has an aluminum body and holds up to 2 oz. of oil
- Uses pressure differential of the high and low side of A/C system

Spring Lock Coupler Set

Packing: 1 Order NO.: 903091

ACT118B



- 4 pc. set aids in disconnecting refrigerant line couplings on many 1981 and later Ford A/C systems
- Color coded:
 - Red, 3/8"
 - Blue, 1/2"
 - Black, 5/8"
 - Beige, 3/4"

Quick Connect Set

Packing: 1 Order NO.: 903092

ACT119



- Simplifies connecting to core valve service fittings
- Includes both a straight coupler and a 90° coupler that accept either of two adaptors (one for low side, one for high side)
- Manual shut-off valves

Antifreeze Hydrometer

Packing: 1 Order NO.: 903094

AF102



- Degree of protection is indicated by direct reading-no temperature compensating scales are required
- Range of +32°F to -60°F
- Includes Celsius scale
- Tests hot and cold solutions

Gas/Diesel Combustion Leak Tester

Packing: 1 Order NO.: 903095

GDCT16



- Provides an easy and quick way to diagnose engine overheating problems
- Checks for leaks between the combustion chamber and the cooling system
- Test head and gasket for combustion leaks before removing the radiator
- Double chamber in testing unit provides a high level of accuracy
- For use on water cooled gas and diesel engines
- Kit includes complete test chamber, 16 oz. bottle of testing fluid and instructions

Cooling System Adaptor Set

Packing: 1 Order NO.: 903096

SVTAB1400



- TAB Series Adaptors feature a composite metal/plastic construction for a lower cost option
- Set includes 14 radiator composite metal/plastic radiator adaptors
- Includes all TAB Series Adaptors plus TA4503 Adaptor
- PBSVTA1417 Storage Case has a removable cover for display purposes

Cooling System Pressure Tester

Packing: 1 Order NO.: 903098

SVT275



- Inflatable bladder sealing system enables use with most passenger and light commercial vehicles
- Tests header tanks and radiator systems as well as thread type and bayonet-style caps
- Locate leaks from head gaskets, radiator and heater cores, Welch plugs and housings, water pumps and hoses
- Test cap relief pressure and seal condition
- Suitable for marine applications
- Fluid drain tube allows coolant to be returned to reservoir or safely collected for recycling
- Bladders are cycle tested to over 1,500 inflations

Fan Clutch Pulley Holder

Packing: 1 Order NO.: 903099

YA6160



- Removes and replaces the fan clutch on vehicles using "bolt on" water pump pulleys
- Reverse pulley holder for assembly operations
- Use with YA9521 36/48mm wrench or YA9526 40mm wrench for many Chrysler, Ford, Lincoln, Mercury and GM applications

Tread Depth Gauge

Packing: 1 Order NO.: 903100

GA599A



- Measures to a depth of 1" in 1/32" increments
- Plastic body with aluminum probe and sliding gauge
- Includes pocket clip

Valve Stem Inserter

Packing: 1 Order NO.: 903001

VT1A



- Simplify installation of valve stem in tubeless tire rim
- Shank is notched to accommodate various rim styles
- Has a comfortable, screwdriver type handle
- 12" long

Universal Valve Core Tool

Packing: 1 Order NO.: 903104

VT14



- Double ended wrench removes and installs large and small valve cores
- Reverse the double ended wrench in the tool body to fit both large and small valve cores
- Use the cup end to remove valve caps
- Valve Stem Inserters
- Simplify installation of valve stem in tubeless tire rim
- Shank is notched to accommodate various rim styles
- Has a comfortable, screwdriver type handle
- 12" long

Tire Gauge and Inflator

Packing: 1 Order NO.: 903101

TPGDL1000



- Measures from 5 to 150 PSI
- Displays reading in psi, bar, kPa or kg/m²
- 1/4" NPT fitting for inlet air connection
- Shock proof rubber guard helps prevent damage if dropped
- On/Off button for display light
- Clip on air chuck
- Batteries included

Pressure Gauge

Packing: 1 Order NO.: 903102

TPGIF1600



- 10 to 120 PSI in 2 pound increments 1/4"
- 1/4" FNPT air inlet fitting
- Swiveling hose for easy gauge positioning
- Zinc body with heavy duty brass valves
- Easy to read sight glass featuring PSI and kPa readings

Pressure Gauge

Packing: 1 Order NO.: 903103

TPGP120



- Calibrated in 2 psi increments from 20 to 150 PSI and in 10 kPa increments from 150 to 800 kPa
- Chrome plated
- 5 3/4" long

1/2" Torque Stick Set, 5 pcs

Packing: 1 Order NO.: 903105

BTQS500



- Entry level set covers the most popular models
- Size ranges from 19 to 22mm
- Torque range from 80 to 147 ft. lbs
- 1/2" drive
- Includes BTQS12B, BTQS12BB, BTQS12C, BTQS12EE and BTQ12SI (5 pcs) in BTQSCASE storage case

1/2" Torque Stick Set, 6 pcs

Packing: 1 Order NO.: 903106

BTQS600



- Set contains sticks to compliment the BTQS1000 set to cover any applications you may still have
- Size ranges from 17 to 22mm
- Torque range from 55 to 113 ft. lbs
- 1/2" drive
- Includes BTQS12AA, BTQS12F, BTQS12G, BTQS12H, BTQS12K and BTQS12MM (6 pcs) in BTQSCASE storage case

1/2" Torque Stick Set, 10 pcs

Packing: 1 Order NO.: 903107

BTQS1000



- Master set covers the majority of domestic and foreign cars and light trucks
- Size ranges from 19 to 24mm
- Torque range from 80 to 160 ft. lbs
- 1/2" drive
- Includes BTQS12A, BTQS12B, BTQS12BB, BTQS12C, BTQS12E, BTQS12EE, BTQS12I, BTQS12T, BTQS12XX and BTQS12Y (10 pcs) in BTQSCASE storage case

Wheel Lock Kit

Packing: 1 Order NO.: 903108

LSR1000A



- Wheel Lock Removal Socket Set
- Easily removes most lug nuts and wheel locks on most domestic and import passenger vehicles and light trucks
- Use with hand driver or impact wrench
- Some sockets cover specific GM, Ford and Chrysler applications
- Set includes 11 sockets, extension and extractor punch in storage case

Inner Tie Rod Tool

Packing: 1 Order NO.: 903110

YA3000C



- Designed to remove tie rods lacking a full hex on the socket end
- Removable crowfoot adaptors are placed on hex of tie rod
- Tool then engages crowfoot for removal or installation of tie rod
- Includes crowfoot adaptors in 1 3/16", 1 1/4", 1 5/16", 1 7/16", 1 1/2" and 33.6mm sizes

Inner Tie Rod Tool

Packing: 1 Order NO.: 903111

YA3100



- Use on inner tie rods with inaccessible wrench flats found on many trucks and SUV's
- Large inner tie rod tool includes 4 crowfoot wrenches: 1 7/16", 33.6mm, 38.4mm and 42mm
- The long socket slips over the tie rod end and the crowfoot engages on socket for easy removal and installation
- Applications include many Toyota, Nissan, Ford, Lincoln Mercury and Chevrolet truck and SUV's
- Also fits some Cadillac Escalade, Hummer H2, Honda Passport and Jeep Liberty

Cam Lock Tool Set

Packing: 1 Order NO.: 903118

ML6000COMBO



- Includes (4) CC100 Single Cam Clamps and (1) ML6000 Dual Cam Clamp in storage tray
- Single cam clamp can be used on engines where the dual clamp will not fit
- Compact design permits easy operation in confined engine areas
- Simple and easy to use
- Manufactured from high strength industrial polymers which will not corrode or damage engine pulleys
- Dual cam clamp prevent engine damage resulting from incorrect timing
- Maintain valve timing during belt replacement on twin and quad cam engines
- Compact design allows access in transverse engines
- Fits timing gear diameters from approximately 4" (101mm) to 6" (152mm)
- Fits gear spacing from approximately 0.06" (1.6mm) to 3" (76mm)

Manual Fluid Dispenser

Packing: 1 Order NO.: 903113

VAC201



- Easily remove engine oil, gear and transmission oil, coolant and brake fluids
- Unit creates vacuum or pressure providing a clean, fast and simple way to evacuate or dispense a wide range of fluids
- Automatic shut off prevents the overflow of the reservoir tank with shut off at 8 liters
- 2.3 gallon (8.8 liter) total capacity
- Durable polyethylene construction is impervious to automotive and house hold chemicals
- No electrical or compressed air required
- Sturdy base with exterior pump helps prevent evacuator from tipping
- Complete system includes manual fluid evacuator, main hose assembly (5/16" ID x 54" long) plus two rigid dipstick tubes for engine oil removal (3/16" ID x 34" and 1/8" ID x 34")

Inner Tie Rod Tool

Packing: 1 Order NO.: 903109

YA3500



- Removes inner tie rods equipped with completely round end sockets or flats
- Designed to remove and install all inner tie rod sockets up to 1 31/64"
- Wrench head has 3 set screws that tighten against the socket
- Includes 1/4" short head hex wrench

Master MacPherson Strut Tool

Packing: 1 Order NO.: 903007

MSC1



- Designed to quickly and easily compress most MacPherson strut springs
- Compresses up to 5/8" (.625mm) coil diameter
- Broad spring contact for stable compression
- Acme threaded rod and built in detent latches to help lock coil in place
- Forged construction for strength and durability

Coil Spring Compressor

Packing: 1 Order NO.: 903112

MSC2



- Removes and installs coil springs quickly and safely
- Compresses coil springs on all passenger cars and pick up trucks
- Features Acme threaded rod

Strap Wrench

Packing: 1 Order NO.: 903114

A91E



- Use on large diameter oil filters 1 to 6"
- Includes both 3/8" and 1/2" square drives

Oil Filter Pliers, Adjustable

Packing: 1 Order NO.: 903008

YA4274



- Use on filters from 2 1/2" to 5 1/4" diameters
- Use on automotive and truck applications
- Spring action size adjustment assures a solid grip on filter
- Offset handle offers increased accessibility
- Heavy duty forged levers
- Cushioned grips for comfort
- Industrial black finish with blue grips
- Overall length of 13 1/2"

Oil Filter Pliers, Extra Large

Packing: 1 Order NO.: 903115

YA4275



- Use on filters from 4 1/4" to 7" (108-178mm) diameters
- Applications include truck, tractor and high torque diesel engines
- Spring action size adjustment assures a solid grip on filter
- Offset handle offers increased accessibility
- Heavy duty forged levers
- Cushioned grips for comfort
- Industrial black finish with blue grips
- Overall length of 19" (482.6mm)

Oil Filter Wrenches

Packing: 1 Order NO.: 903108



Stock No.	Size (mm)	Steps	Flats	Style	Packing	Order No.
FW656714A	65,67	2	14	Cup	1	903009
FW757715A	75,77	2	15	Cup	1	903010
FW7630A	76	1	30	Cup	1	903011
FWA62121A	62,121	—	—	Adjustable	1	903012

Stock No.	Square Drive (inches)	Application
FW656714A	3/8	Fram-PH4386, PH4967, PH6017, PH6018, PH6607
FW757715A	3/8	NAPA, AC Delco, Castrol, STP, Penske
FW7630A	3/8	Fram, IAPCO, Motorcraft, Parts Plus, Pennzoil
FWA62121A	3/8	Adjustable filter wrench for 62 to 121mm diameter oil filters, 3/4" external hex

Funnel

Packing: 1 Order NO.: 903116

FUNN15



- High visibility red funnel for large neck fillers
- Both ends of the funnel have screw on caps to contain fluids if needed
- 1.5 qt. capacity

Oil Filter Wrench Set, 7 pcs

Packing: 1 Order NO.: 903013

FWK7A



- Wrenches in set cover 95% of domestic and import automobile and light truck oil filters
- Storage/carrying case keeps wrenches together for quick access and contains any oil residue keeping it out of your tool storage unit
- Includes laminated application chart
- FWK7A set includes FW656714A, FW757715A, FW7614A, FW7630A, FW8015, FW9315A and FWA62121A oil filter wrenches

Grease Gun, Air

Packing: 1 Order NO.: 903016

YA772B



PSI	Air Operating PSI	Pump Ratio
4,000	60 - 150	40:1
Capacity	Flexible Hose	Rigid Extension
14 oz. Cartridge	18	6
Loading	Nozzle	—
Bulk, Filler Pump, or Cartridge	—	—

- Automatic operation provides continuous grease flow with trigger depressed
- Pumps at a 40:1 ratio with a maximum pressure of 6,000 PSI
- Use with standard 14 oz. cartridge, bulk fill or filler tube
- Heavy duty 18" flexible nylon hose improves accessibility and reach
- Air vent allows easy removal of trapped air after loading grease tube
- Light weight of 3.52 lbs
- Helps reduce operator fatigue

Accessory Pack, Grease-dispensing

Packing: 1 Order NO.: 903015

YA7500



- Includes 10 pcs. as follows in a storage tray
- Universal swivel Needle nozzle coupler
- Flex whip hose 12"
- Flex whip hose 18" (for manual grease guns)
- Flex whip hose 18" (for powered grease guns)
- Heavy duty coupler
- Swivel coupler
- Coupler
- Coupler extension
- Angle lube adaptor

12" Hose

Packing: 1 Order NO.: 903019

YA751



- For powered and hand operated grease guns
- 1/8" NPT(m) both ends
- 4,500 maximum PSI
- 12" long

18" Hose

Packing: 1 Order NO.: 903020

YA752



- 18" long version of YA751

Grease Gun

Packing: 1 Order NO.: 903014

GA472



Specification	PSI	Nozzle
Pistol Grip	5,000	13 1/4
Capacity	Flexible Hose	Rigid Extension
14 oz.	—	3 1/2
Loading	—	—
Bulk, Cartridge, or Filler Pump	—	—

- Standard series grease guns
- All are steel with zinc plating
- Inner-spring chamber can be either cartridge or bulk loaded

Grease Gun, Lever

Packing: 1 Order NO.: 903022

YA728A



Specification	PSI	Nozzle
Lever	6,000	—
Capacity	Flexible Hose	Rigid Extension
16 oz. Bulk and 14 1/4 oz. Cartridge	18"	6"
Loading	—	—
Bulk or Cartridge	—	—

- Lever operated, large capacity gun accepts 16 oz. bulk or 14 1/4 oz. cartridge grease
- Develops 6,000 PSI
- Includes tough, 18" flexible whip hose with coupler and 6" rigid extension

Grease Gun, Pistol

Packing: 1 Order NO.: 903017

YA734A



Specification	PSI	Nozzle
Pistol Grip	6,000	—
Capacity	Flexible Hose	Rigid Extension
16 oz. Bulk and 14 1/2 oz. Cartridge	18"	6"
Loading	—	—
Bulk or Cartridge	—	—

- Develops 6,000 PSI maximum pressure
- Pistol grip unit features suction, cartridge, or filler pump loading
- Includes flip over follower, 18" flexible hose, 6" rigid extension and hydraulic coupler

Nozzle, Needle

Packing: 1 Order NO.: 903018

YA750



- 1/8" NPT(f.) thread
- 2 3/4" long

Adaptor, Needle Type

Packing: 1 Order NO.: 903021

YA801



- For universal joint fittings, water pumps, and metal covered springs
- 4 7/8" long

Oil Suction Gun

Packing: 1 Order NO.: 903117

YA745A



- 16 oz. capacity
- Fast, clean method for removing or adding transmission and gear oil
- Special follower is impervious to oil, grease, and water
- Flexible nozzle

Serpentine Belt Tool Kit

Packing: 1 Order NO.: 903119

YA9350B



- Hex Applications
 - YA9350-6 (13mm or 1/2") - GM "Quad 4" 2.3L and Volkswagen 2.0L
 - YA9350-2 (14mm) - Isuzu 3.1L, Lexus (2.5L, 3.0L, 4.0), Mazda (2.3L, 3.0L, 4.0L), Saturn 1.9L with 4mm hex on idler pulley, Toyota 3.0L, Volkswagen (1.8L, 2.5L, 2.8L)
 - YA9350-8 (15mm) - GM 2.2L, Isuzu 2.8L, Jeep 4.7L
 - YA9350-7 (16mm or 5/8") - Ford/Lincoln/Mercury (2.3L, 3.8L, 4.0L, 4.9L, 5.0L, 5.8L), GM (4.3L, 5.0L, 5.7L)
 - YA9350-3 (18mm) - GM (2.0L, 3.1L, 3.3L, 3.4L, 3.8L)
 - YA9350-9 (19mm or 3/4") - Mercedes (use with 15mm adapter for extra reach), Toyota (1.8L, 2.4L)
- Wrench Only - Dodge/Chrysler/Plymouth (3.0L, 3.3L, 3.9L) (has 15mm drive), Ford/Lincoln/Mercury (2.3L, 3.0L, 3.8L)
- Square Applications
 - YA9350-4 (3/8") - Ford/Lincoln/Mercury (1.9L, 2.3L, 2.5L, 4.0L), GM (2.0L, 2.2L, 2.8L, 3.1L, 3.4L), Isuzu (2.8L, 3.1L)
 - YA9350-5 (1/2") - Dodge/Chrysler/Plymouth (2.0L, 3.0L), Ford/Lincoln/Mercury (2.3L, 3.0L, 4.2L, 4.6L)

Serpentine Belt Tool

Packing: 1 Order NO.: 903120

SBT26



- Works on all serpentine belts
- Clamping jaw allows user to position serpentine belt without the belt slipping out of the tool
- Positive grip allows belt routing in tight access areas that would normally be difficult to reach
- Ergonomic handle provides comfort and ease in use, acting as an extension of the user's hand
- Lightweight steel body for durability and strength

Air Adjusting Valve, with Gauge

Packing: 1 Order NO.: 903145

BF555



- Designed for use with HVLP spray guns
- Includes 160 PSI pressure gauge
- Air Inlet: 1/4" M.P.T
- Air Outlet: 1/4" F.P.T. (swivel nut)

Seal Pliers

Packing: 1 Order NO.: 903023

YA8230



- Removes valve stem seals from overhead camshaft engines including 4 valve per cylinder engines that have restricted access to the valve stem seal due to the head design
- Gripping serrations in the pliers tip easily grab both OEM and aftermarket seals with ease
- Easy grip handles

Ring Compressor, Set

Packing: 1 Order NO.: 903124

RC980



- Works both horizontally and vertically with pliers grip handle
- Has a fine tooth ratcheting mechanism
- Includes 6 hardened steel bands:
 - 2 7/8" to 3 1/8", 3 1/8" to 3 3/8", 3 3/8" to 3 5/8", 3 5/8" to 3 7/8", 3 7/8" to 4 1/8", and 4 1/8" to 4 3/8"

Valve Spring Compressor

Packing: 1 Order NO.: 903121

CF700B



- 7/8" to 2 1/2" capacity
- Operates on 90 PSI to 150 PSI, but develops up to 3 times output pressure
- Tool measures 1" x 8"

C-Clamp Compressor

Packing: 1 Order NO.: 903122

CF811B



- 1" to 2" capacity
- For "L" head, valve-in-head, high compression engines and vehicles with overhead valves
- Activating mechanism prevents cocking of valve spring as it is compressed

C-Clamp Compressor

Packing: 1 Order NO.: 903123

CF19B



- This compact model includes CF19-3A Jaws for 1/4" to 1 1/16" diameter springs on small, air cooled engines and CF19A5 Jaws for both 17mm and 20.8mm diameter springs on Honda engines

Ring Compressors

Packing: 1 Order NO.: 903024

RC40C



- | Stock No. | Band | Capacity (inches) | Deep (inches) | Order No. |
|-----------|------|-------------------|---------------|-----------|
| RC40C | 2 | 2 1/8 to 5 | 3 1/2 | 903024 |
| RC50C | 2 | 3 1/2 to 7 | 3 1/2 | 903025 |
- Clutch control holds tension band in position as piston is inserted into cylinder
 - 1/2" wide spring bands equalize tension over belt width so ring assembly may be compressed into groove until flush with piston
 - "V" beads on lower edge of belt keep tool from entering cylinder
 - RC40C can be used upside down for Chevrolet, Mercury, and Ford trucks with angled blocks

Bearing Race and Seal Driver Set

Packing: 1 Order NO.: 903125

A1310A



- Collars fit most standard wheel bearing sizes
- The three largest sizes fit most late model 4 wheel drive vehicles

Rotor Micrometer

Packing: 1 Order NO.: 903030

RM130



- Range of .30" to 1.3" in .0001" graduations
- 3.5" deep frame
- Pointed anvil for checking grooves
- Includes 1" checking standard and storage case

Oval Tube Creeper

Packing: 1 Order NO.: 903126

JCW8A



Pad Color	Overall Size (inches)	Pad Length (inches)
Black	40 (L)x17 (W)x4 (H)	39
Pad Width	Number of Casters	Caster Diameter (inches)
11	4	2 1/2

- 40" long creeper is constructed of 16 ga. steel and has a unique drop in the shoulder area to provide for generous shoulder clearance low 3/4" ground clearance
- Fully padded with heavy duty foam for durability; pad measures 1 3/4" thick, headrest pad measures 2 3/4" thick covered with heavy duty vinyl
- Four 2 1/2" oil resistant, full ball bearing casters
- Weight is 18 lbs

Creeper Seat

Packing: 1 Order NO.: 903026

JCW9



Pad Color	Overall Size (inches)	Seat Size (inches)
Black	17 (L)x20 1/2 (W)x15 (H)	7 (L)x14 (W)

- Distinctive style, heavy duty mechanic's seat is constructed of heavy duty 16 ga. steel
- Seat pad is supported by two support bars for additional strength; fully padded with heavy duty foam that measures 1 3/4" thick, and overall pad measures 7" x 14"; covered with heavy duty vinyl
- Bottom storage tray measures 16 1/2" x 14"
- Four 2 1/2" oil resistant, full ball bearing casters
- Weight is 18 lbs

Brake Bleeding Kit

Packing: 1 Order NO.: 903028

BB500



- Kit includes BB5001 vacuum brake bleeder and BB5002 auto refiller bottle
- BB5001-large 3-pint (1.5 liter) container
- Generates 25 in Hg vacuum with air pressure of 100 psi
- On/OFF valve and Flow Regulator
- Quick release locking trigger and safety shut off valve
- Overfill check valve
- Compact design-fits under wheel well
- 19.5" (500mm) suction hose
- Universal brake screw fitting
- BB5002-20 fluid oz. (592 ml) container
- the correct level
- Automatically keeps the reservoir filled to the correct level
- Retaining clip for positive attachment
- Compact design-fits under hood
- Positive venting system supplies continuous flow
- Unit can be sealed when not in use to prevent spillage

Brake Spring Tool

Packing: 1 Order NO.: 903127

BT9



- Quickly and easily removes or replaces springs
- Allows mechanics to press spring into place with one simple motion, taking the place of the slide mechanism
- Includes two mechanisms to allow easy removal and replacement of springs on brakes
- Patent pending
- 8 3/4" long

Brake Caliper Kit, 7pcs

Packing: 1 Order NO.: 903033

YA8610B



- Assists in replacement of brake pads on most 4-wheel disc brake cars
- Tool and adaptors position brake piston back into caliper to allow clearance for newer, thicker brake pads
- Designed for most Audi, Chrysler Corporation, Ford, GM, Honda, Jaguar, Mazda, Mini Cooper, Mitsubishi, Nissan, Saturn, Subaru, Toyota, Volkswagen and Volvo
- Set includes one tool and seven adaptors in a storage case

Brake Caliper Press

Packing: 1 Order NO.: 903032

BTCP1



- Works on both fixed and floating calipers
- Generates more than 1600 ft. lbs. of force to retract the toughest caliper pistons
- Single lever mechanism used to apply and release force for ease of operation and faster service
- Prevents damage to pistons, hubs or calipers
- Ensures parallel piston retraction on dual and quad piston calipers
- Easy left and right side use

Brake Gauge Set

Packing: 1 Order NO.: 903130

BTG8



- Color coded gauges provide instant feedback on brake pad/shoe condition
- Constructed from 20 gauge sheet metal with durable powder coat finish
- Pad/shoe condition is indicated with color by the respective testing gauge
- Red indicates service required, yellow indicates caution and green indicates an OK situation
- Set includes 8 different testing blades of various colors and thickness
 - Red 2mm (0.0787")
 - Red 3mm (0.1181")
 - Yellow 4mm (0.1575")
 - Yellow 5mm (0.1969")
 - Yellow 6mm (0.2362")
 - Green 8mm (0.3150")
 - Green 10mm (0.3937")
 - Green 12mm (0.4724")

Throttle Depressor

Packing: 1 Order NO.: 903131

B240B



- Holds throttle at a constant RPM
- Easily adjusts to desired length
- Adjustment screw fine tunes desired RPM
- Rubber tip keeps the tool firmly positioned on the accelerator pedal
- Overall length of 40" (102cm)
- Can also be used as a pedal depressor

Thread Setter Kits

Packing: 1 Order NO.: 903135



Stock No.	Order No.
HP650	903134
HP650M	903135

- HP650**
- Includes: rugged thread setter tool and an assortment of fractional Klik Poly-Nuts: 12 each 8-32, 10-24, 10-32; (8) 1/4"-20 and (6) 5/16"-18 threads
 - Includes required nosepieces and mandrels for setting the above sizes
 - Packaged in a storage case
- HP650M**
- Metric version of the HP650 with metric poly-nuts, including 25 each 4 and 5mm, (15) 6mm and (10) 8mm threads
 - Includes thread setter tool, required nosepieces and mandrels packaged in a storage case

Air Riveter

Packing: 1 Order NO.: 903133



Recommended Air Pressure (psi)	Air Consumption, average cfm (scfm) [l/min]
85-95	—
Air Inlet Thread Size	Traction Power (lbs)
1/2" NPT	3,300
Stroke	Weight (kg.)
5/8" (15.8 mm)	3.0

- Sets structural rivets, KLIK-FAST® rivets from 5/32" to 1/4" diameter in all alloys plus KLIK-SPLIT® / Monobolt rivets from 3/16" to 1/4"
- Includes 5/32", 3/16" and 1/4" nosepieces plus mandrel collection bottle

Brake Service Tools

Packing: 1 Order NO.: 903146



- Produces vacuum or pressure at the turn of a switch
- Comfortable ergonomic design
- One finger trigger vacuum/pressure release
- Durable, accurate diaphragm type pressure/vacuum gauge
- Handheld vacuum/pressure pump with 2" compound gauge and rubber boot
- 12 oz. fluid reservoir bottle with fluid transfer and storage lids plus fluid pick up tube
- 6 tapered adaptors for connecting to tubing from .09" to .50" ID
- 2 tapered manifold plugs
- 2 universal bleed screw adaptors
- 12 vacuum cap plugs, vacuum line T-adaptor
- (2) 1/4" ID x 24" long connection tubes with quick-change connector
- 5/32" ID x 1/4" ID tubing adaptor
- 5/32" ID x 3" long vacuum test tube
- Rubber cupped adaptor
- Master cylinder refill kit
- Applications:
 - Vacuum and pressure related engine performance diagnostics and tune-ups
 - Brake bleeding
 - Fluid transfer, evacuation and sampling

Door Lockout Set

Packing: 1 Order NO.: 903136



- No danger of airbag activation or disconnected door linkages
- Actuate the door handle, manual lock button or electric lock button on most cars and trucks
- Includes:
 - 4 pc door-unlocking tool that screws together without couplers for easy assembly and storage, plastic slim jim, 2 glow-in-the-dark tips, 2 plastic wedges to create gap between door and frame without damaging door or weather stripping and BF272 inflatable wedge
- Use the BF272 to easily separate door from body without damage to the vehicle
- Unlocking tool features a middle extension piece to reach across the car in extended use applications
- For sale to registered locksmiths, police and bona fide repair professionals only

HVLP Spray Gun



Stock No.	BLP13HVLP	BLP14HVLP	BLP15HVLP	BLP18HVLP
Fluid Tip (mm)	1.3	1.4	1.5	1.8
Air Consumption (scf m)	9.5	9.5	9.5	9.5
Max. Inlet HVLP psi (bar, kPa)	29 (2.0, 20.0)	29 (2.0, 20.0)	29 (2.0, 20.0)	29 (2.0, 20.0)
Dry Weight without Cup, oz. (grams)	12.6 (359)	12.6 (359)	12.6 (359)	12.6 (359)
Air Inlet Thread Size	1/4" NPSM	1/4" NPSM	1/4" NPSM	1/4" NPSM
Cup Size (cc)	600	600	600	600
Application	High solids, colors and clears	High solids, colors and clears	Medium solids, colors and clears	Primer, high viscosity materials
Order No.	903140	903142	903143	903144

- A new generation of Blue-Point® spray guns for primer, base and clear coat
- Designed for the automotive refinishing painter, Blue-Point® spray guns are lightweight and feature great balance while delivering a quality, first class automotive finish
- Lowest trigger pull among guns in their class
- Unmatched spray pattern size and quality repair kits
- Optional interchangeable 125cc, 250cc and 600cc aluminum cups are available
- Optional 3M PPS adaptor is also available

1.0 Mini HVLP Spray Gun

Packing: 1 Order NO.: 903139



Fluid Tip (mm)	Air Consumption (scfm)	
1.0	7.0	
Max. Inlet HVLP psi (bar, kPa)	Dry Weight without Cup, oz. (grams)	
29 (2.0, 20.0)	11.4 (322)	
Air Inlet Thread Size	Cup Size (cc)	Application
1/4" NPSM	125	Primer, base and clear

- A new generation of Blue-Point® spray guns for primer, base and clear coat
- Designed for the automotive refinishing painter, Blue-Point® spray guns are lightweight and feature great balance while delivering a quality, first class automotive finish
- Lowest trigger pull among guns in their class
- Unmatched spray pattern size and quality repair kits
- Optional interchangeable 125cc, 250cc and 600cc aluminum cups are available
- Optional 3M PPS adaptor is also available

1.4 Conventional Spray Gun

Packing: 1 Order NO.: 903141



Fluid Tip (mm)	Air Consumption (scfm)	
1.4	9.5	
Max. Inlet HVLP psi (bar, kPa)	Dry Weight with out Cup, oz. (grams)	
—	12.6 (359)	
Air Inlet Thread Size	Cup Size (cc)	Application
1/4" NPSM	600	All automotive colors and clears

- A new generation of Blue-Point® spray guns for primer, base and clear coat
- Designed for the automotive refinishing painter, Blue-Point® spray guns are lightweight and feature great balance while delivering a quality, first class automotive finish
- Lowest trigger pull among guns in their class
- Unmatched spray pattern size and quality repair kits
- Optional interchangeable 125cc, 250cc and 600cc aluminum cups are available
- Optional 3M PPS adaptor is also available

1.4 HVLP Spray Gun

Packing: 1 Order NO.: 903138



Fluid Tip (mm)	Air Consumption (scfm)
1.4	14.5
Air Inlet Thread Size	Air Pressure Range (psi)
1/4" NPSM	30 to 43
Fluid (Water) Delivery	Cup Size (cc)
190 to 250 ml/min	600

- Lightweight and comfortable for all kinds of painting jobs
- Provides superior spray performance
- Stainless steel needle and tip

High Volume Hose Connectors



Stock No.	Description	Size	Order No.
AHCC90C	Quick Coupler High volume 1/4" female quick coupler	1/4"	903147
AHCC91B	Quick Coupler High volume 1/4" male quick coupler	1/4"	903148
AHCCP90C	Nipple (1/4" Female) Quick connect 1/4" female nipple	1/4"	903149
AHCCP97C	Impact Wrench Adaptor	1/2"	903150

- AHCC90C AHCC91B AHCCP90C
- Designed to deliver high volumes or air to spray guns and air tools
- AHCCP97C
- Use with AHCC98C high flow coupler to improve low pressure performance of 1/2" drive impact wrenches and other high air consumption tools

Windshield Removal Tool

Packing: 1 Order NO.: 903137



- Steel cable pull handle
- Replaceable steel cutting blades can be resharpened
- For GM, Chrysler, and other cars with windshields set in place with sealant



Shop Equipment



Bringing on bigger sized gear, we have some heavier equipment further catering to automotive specialized needs. All equipment conform to Blue-Point's quality commitment, and complement the rest of our quality tools to be the number one choice in automotive tools.

2 Ton Floor Jack

Packing: 1 Order NO.: 904003

YA1642A



3-1/2 Ton Floor Jack

Packing: 1 Order NO.: 904004

YA1707



Stock No.	Capacity (tons)	Max Lift Height (inches)	Low Height (inches)	Saddle Size (inches)	Frame Length (inches)	Handle Length (inches)	Weight (lbs)
YA1642A	2	19 1/2	5 1/2	5 1/8	25 3/8	42 1/8	73
YA1707	3 1/2	22	3 3/4	4 1/4	29 7/8	50	103

- Fast acting pump reaches lifting height in less than a pump to allow user to reach a variety of service height situations quickly
- One piece handle for professional users features a foam pad to limit damage to vehicles
- Universal joint release mechanism for smooth action
- Rolled side frames with generous flanges to resist flexing
- Low profile design allows for easy access under vehicles
- Floor Jack used to lift cars and light trucks
- Meets ANSI-PALD standards

Motorcycle Floor Jack

Packing: 1 Order NO.: 904009

YA1715



2 Ton Low-profile Floor Jack

Packing: 1 Order NO.: 904010

YA1716



- 1,500 pound capacity
- Low height of 4 1/2", maximum height of 14 3/4"
- Wide base for extra stability
- Double rubber lined pad provides extra protection to motorcycle while on the jack
- Pull handle assists user to maneuver jack into position
- One foot operation for ease of use
- Safety straps to secure motorcycle to jack
- Self locking safety feature and overload safety valve

Stock No.	Capacity (tons)	Max Lift Height (inches)	Low Height (inches)	Saddle Size (inches)	Frame Length (inches)	Handle Length (inches)	Weight (lbs)
YA1716	2	20	3	—	30 1/4	40	97

- Lift arm is made of ductile iron and is stronger than stamped designs
- 1 pc handle with universal release mechanism
- Fast acting pump brings saddle to service height quickly
- Side plates are flanged for additional strength

12 Ton Jack Stands

Packing: 1 Order NO.: 904006

YA512



Stock No.	Capacity (tons)	Low Height (inches)	Maximum Height (inches)
YA512	12 (per pair)	17 1/2	27 1/2

- Counter-weighted pawl serves as a secure locking device to prevent the load from accidentally disengaging
- Sturdy, welded steel construction for superior strength
- One piece, multi-position ductile ratchet bar provides super strength and durability and quick adjustment mechanism that securely locks into desired location

1/2 Ton Trans Jack

Packing: 1 Order NO.: 904007

YA714D



Capacity (tons)	Maximum Height (inches)	Saddle Base (inches)	Lifting Head Size (inches)
1/2	69 7/8	8 7/8 x 7 1/8	15 1/2 x 15 1/2
Handle Length (inches)	Chassis Length (inches)	Chassis Width (inches)	Tilt
11	—	33 1/2	12°
Minimum Height (inches)	Exp.Saddle Area (inches)	Jack Size (inches)	Net Weight, lbs. (kg)
33	21 x 21	34 1/8 (L) x 36 1/8 (W)	181 (82.1)

- Crank for precise and easy alignment
- Four adjustment load support arms fit most transmission pan flanges
- Adjustable to 0.030 inches or less
- Foot pedal pump permits hands free operation
- Wide base and four casters for stability

2 Ton Folding Engine Crane

Packing: 1

Order NO.: 904008

YA778



- Lift arm extends from 27" to 55"
- Lift arm extends to a height of 94.5"
- External remote pump with fine adjustment gets you closer to the work
- Foldable hoist stores easily-only a 25" x 33" footprint when folded
- 360° Swivel Hook allows work to move easily when hook is loaded
- Maximum 2 ton lifting capacity

8 Ton Bottle Jack

Packing: 1

Order NO.: 904005

YA1228



Capacity (tons)	Low Height (inches)	Maximum Height (inches)	Screw Extension (inches)
8	8 1/8	17 5/8	2 3/4
Base Size (inches)	Handle Length (inches)	Cap Diameter (inches)	Operating Force(lbs.)
4 3/4 x 4 3/4	18 1/8 (assembled)	1 3/8	101

- Hydraulic system is protected from internal damage by a patented by-pass mechanism
- Machined and polished cylinders with die-cut threading provide non-abrasive leak-free, durable performance
- Fabricated from hard-cast steel

Heavy Duty Workbench

Packing: 1

Order NO.: 904001

BPWORKBENCH



- Features a full bottom shelf and superior powder coat finish
- Dimensions-60.08" x 30.73" x 34.08"
- Net Weight-138.9 lbs. (63.06 kg)
- Weight Capacity-1,200 lbs.
- Top panel: 2.0mm thickness
- Bottom shelf: 2.0mm thickness
- Steel support: 2.5mm thickness

Welder & Plasma Cutter Cart

Packing: 1

Order NO.: 904002

MIGCARTA



Overall Dimensions	Shipping Weight (lbs.)
41" L x 19 1/2" W x 25" H	43

- Welder and plasma cutter cart features two trays along with 20" (L) x 12.75" (W) top tray to hold MIG welders and plasma cutters
- Includes cylinder bracket with adjustable chain to hold multiple diameter gas bottles
- Handle has storage tray for smaller items

Important Words About Safety for Users and Bystanders

Following these basic safety rules
is a good start toward
protecting yourself and others
in the vicinity
from injury while using tools

- **Wear safety goggles**
- **Use the right tool**
- **Use the tool properly**
- **Maintain the tool regularly**
- **Keep tools away from children**
- **Do not use tools on live electrical circuits unless specifically designed for such use**
- **Read and follow instructions**

Prohibited Actions	Mandatory Actions	Hazard Alerts
<p>THIS SYMBOL INDICATES PROHIBITED ACTION</p>	<p>THIS SYMBOL INDICATES MANDATORY ACTION</p>	<p>THIS SYMBOL INDICATES A HAZARD ALERT</p> <p>RED BACKGROUND - DANGER ORANGE BACKGROUND - WARNING YELLOW BACKGROUND - CAUTION</p>
<p>DO NOT OVER-TORQUE NO PIPES OR LEVER EXTENSIONS</p>	<p>MANDATORY EAR PROTECTION</p>	<p>VIBRATION HAZARD</p>
<p>NO HAMMERING</p>	<p>MANDATORY FACE SHIELD</p>	<p>RISK OF EXPLOSION</p>
<p>NO PRYING</p>	<p>MANDATORY MASK</p>	<p>OVERHEAD/OVERLOAD HAZARD</p>
<p>DO NOT STRIKE HARD OBJECTS</p>	<p>MANDATORY RESPIRATOR</p>	<p>RISK OF ELECTRIC SHOCK</p>
<p>NO IMPACT/POWER DRIVE</p>	<p>MANDATORY PROTECTIVE CLOTHING</p>	<p>RISK OF FIRE</p>
<p>DO NOT STEP IN OR ON DRAWERS</p>	<p>MANDATORY PROTECTIVE GLOVES</p>	<p>RISK OF ENTANGLEMENT</p>
<p>DO NOT OPEN MULTIPLE DRAWERS</p>	<p>MANDATORY EYE PROTECTION</p>	
<p>DO NOT PULL TO MOVE</p>	<p>MUST READ INSTRUCTIONS BEFORE USE</p>	
<p>KEEP CHILDREN AWAY</p>		

Safety messages in this catalog use the guidelines of the American National Standard ANSI Z535. 4 for Product Safety Signs and Labels and ANSI Z535.3 Criteria for Safety Symbols. Messages associated with specific products use a triangular hazard alert symbol, signal word (CAUTION, WARNING, DANGER) and how to avoid the hazard.

PLEASE READ AND FOLLOW these messages to avoid injury to yourself and bystanders.

Snap-on Asia Pacific Division, or its assigns, ("Snap-on") warrants to customers who purchase products from authorized Blue-Point distribution channels that Blue-Point® brand products will be free from defects in workmanship and materials for a duration depending upon the nature of the product. Prior to a product purchase, customer can obtain the product warranty duration from a Blue-Point reseller. Customers may also contact the closest sales office as listed below.

During the applicable duration of the warranty, at its option, Snap-on will repair or replace its products which fail to give satisfactory service due to defective workmanship or materials, or provide a refund by repaying or crediting customer with an amount equal to the purchase price of such products. Repair, replacement or refund shall be at the election and expense of Snap-on, and is customer's exclusive remedy in place of all other rights and remedies. Any products or parts replaced or for which Snap-on has provided a refund are the property of Snap-on and will not be returned.

THE FOREGOING WARRANTY IS IN LIEU OF AND EXCLUDES ALL OTHER WARRANTIES NOT EXPRESSLY SET FORTH HEREIN, WHETHER EXPRESS, IMPLIED OR COLLATERAL, BY OPERATION OF LAW OR OTHERWISE, INCLUDING BUT NOT LIMITED TO ANY IMPLIED WARRANTIES OF MERCHANTABILITY OR FITNESS FOR A PARTICULAR PURPOSE. Descriptions of product contained in this catalog are for the sole purpose of identifying product and shall not be construed as an express warranty.

LIMITATION OF LIABILITY. SNAP-ON AND ITS AFFILIATED COMPANIES AND THIRD PARTY SUPPLIERS SHALL NOT BE LIABLE FOR ANY INCIDENTAL, SPECIAL OR CONSEQUENTIAL LOSSES, COSTS OR DAMAGES INCURRED BY CUSTOMER OR OTHERS, INCLUDING PERSONAL INJURY OR DEATH, DIRECTLY OR INDIRECTLY ARISING FROM THE SALE, HANDLING OR USE OF THE PRODUCTS, OR FROM ANY OTHER CAUSE WITH RESPECT TO THE PRODUCTS OR THE FOREGOING WARRANTY, WHETHER SUCH CLAIM IS BASED UPON BREACH OF CONTRACT, BREACH OF WARRANTY, STRICT LIABILITY IN TORT, NEGLIGENCE OR ANY OTHER LEGAL THEORY (INCLUDING WITHOUT LIMITATION, LOST PROFITS, REVENUES, ANTICIPATED SALES, BUSINESS OPPORTUNITIES, GOODWILL, OR INTERRUPTION OF BUSINESS OR OTHER INJURY OR DAMAGE).

Snap-on® and Blue-Point® are registered trademarks of Snap-on Incorporated

SNAP-ON ASIA PACIFIC OFFICES

Asia / Pacific Division

25 Tagore Lane, #01-02
Singapore 787602
Tel: +(65) 6459-2712
Fax: +(65) 6459-1520

Snap-on Trading (Shanghai) Co., Ltd.

Unit 2001-2005, Ascendas Cross Tower
318 Fuzhou Road, Shanghai 200001
P.R.China
Tel: +(86-21) 6391-2388
Fax: +(86-21) 6391-2382

Snap-on Trading (Shanghai) Co., Ltd. Beijing Branch

517B, Grand Pacific Building
8A Guanghua Road
Beijing 100026
P.R.China
Tel: +(86-10) 6581-8838
Fax: +(86-10) 6581-6681

Snap-on Tools India Private Ltd.

6/2, Begumpur Khatola,
39 Milestone, NH-8, Gurgaon,
Haryana-122004, India
Tel: +(91-124) 459-9700
Fax: +(91-124) 405-6866

Snap-on Tools Japan, K.K.

2-1-6 Shinkiba, Koto-ku,
Tokyo, 136-0082 Japan
Tel: +(81-3) 5534-1285
Fax: +(81-3) 5534-1284

Snap-on Tools Hong Kong Ltd.

Unit 2010, 20/F, Laford Centre,
838 Lai Chi Kok Road,
Cheung Sha Wan, Kowloon
Hong Kong
Tel: +(852) 2370-3700
Fax: +(852) 2370-3400

Snap-on Tools Korea Ltd.

#505, Building 301,
Bucheon Techno Park Block 3
365 SamJung-Dong,
OhJung-Gu, Bucheon City
GyeongGi-Do 421-809, Korea
Tel: +(82-32) 326-7310
Fax: +(82-32) 326-7312

Snap-on Tools Singapore Pte. Ltd.

25 Tagore Lane, #01-01
Singapore 787602
Tel: +(65) 6451-5570
Fax: +(65) 6451-5574

Snap-on Tools Singapore Pte. Ltd. Indonesia Representative Office

Graha Pratama Building, 20th Floor
Jl. M. T. Haryono Kav.15,
Jakarta 12810, Indonesia
Tel: +(62-21) 8370-9611
Fax: +(62-21) 8370-9612

Snap-on Tools Singapore Pte. Ltd. Malaysia Branch

Block A, Unit 3-2, Jaya One
Level 2, No. 72A, Jalan Universiti
46200 Petaling Jaya
Selangor, Malaysia
Tel: +(603) 7957-3088
Fax: +(603) 7958-2088

Snap-on Tools Singapore Pte. Ltd. Philippines Branch

4/F, 2053 Building, Edison Street
San Isidro, Makati City
Philippines 1234
Tel: +(63-2) 843-7935
Fax: +(63-2) 843-7730

Snap-on Tools Singapore Pte. Ltd. Taiwan Branch

3F, -4, No 9 Wuchuan 1st Road
Wu-ku Industry Park,
Taipei County 24892, Taiwan R.O.C.
Tel: +(886-2) 2298-9789
Fax: +(886-2) 2298-2288

Snap-on Tools Singapore Pte. Ltd. Snap-on (Thailand) Company Ltd.

5th Floor, Talomsin Building,
924 Rama 3 Road
Bangpongpang Yannawa,
Bangkok 10120, Thailand
Tel: +(66) 2294-9660
Fax: +(66) 2294-9665

Adjustable Pliers	55, 57
Adjustable Wrench	36, 38
Air Cutter	81
Air Drill	77-78
Air Grinder	78-81
Air Hammer	78
Air Polisher	85-86
Air Ratchet	75-77
Air Sander	83-85
Air Saw	82
Air Tool	72-86
Battery Tester	138
Blow Gun	96
Borescope	126
Breaker Bar	12-13, 20, 26, 31, 33
Caliper	113
Circuit Tester	132
Clamp	150
Combination Wrench	39
Cordless Drill	87
Cordless Impact Wrench	87
Drill Bits	97
Ear Muffler	119
Extension	10, 12-15, 19, 25-27, 30, 33, 89-90, 92, 94
Feeler Gauge	110-112
Glove	118, 122-123
Grease Gun	148-149
Grinding Wheel	95-96
Hammer	100-102
Hose	140
Impact Socket	88-94
Impact Wrench	72-75
Jack	158-160
Knife	105-106
Light	87, 116-117
L-Shape Wrench	38, 43
Magnetic Tool	119-121
Measuring Tape	112
Micrometer	114, 151
Multimeter	132, 134
Offset Wrench	40
Oil Filter Wrench	148
Open End Wrench	39
Personal Protective Equipment	118-119
Pick	127
Pliers	52-61
Prybar	130
Punch	102
Ratchet	10-15, 19, 24, 27, 30, 33
Ratcheting Wrench	14-15, 36-38, 40-41
Retaining Ring Pliers	54
Roll Cabinet	2-3
Roll Cart	4-5
Safety Glass	119
Scraper	103-104
Screwdriver	46-48
Screwdriver Bits	49
Shear	104
Socket	10-15, 18-33, 88-94
Socket Adaptor	13, 15, 20, 26, 31, 89-90, 92, 94
Socket Driver	10-15, 21-22, 27-28, 31-32
Socket Universal Joint	10, 13-15, 20, 25, 31, 33, 89, 91-92, 94
Spray Gun	154-155
Thermometer	136, 140-141
Tool Bag	5
Tool Box	5-7
Tool Set	10-15
Tool Storage	2-7
Tool Tray	129
Torque Tester	69
Torque Wrench	66-68
Tweezer	127
Vise	122
Wire Cutter	127-128
Wire Stripper	127
Workbench	161

1-9

303DJCP	53
613DJCP	53
913DJBCP	53
913DJCP	53
1412A	128
1658C	128
2420A	128
2430C	128
2438C	128
2842C	128

A

A91E	147
A1310A	151
AC2Z40T27MP	95
AC2Z60T27MP	95
AC2Z80T27MP	95
AC4Z60T27MP	95
AC17D	95
AC243	95
AC420A	95
AC421A	95
AC616	95
AC3160FWMP	95
AC3180FWMP	95
AC10302	95
AC10306	95
AC31120FWMP	95
ACT73A	140
ACT83A	141
ACT106B	142
ACT111B	142
ACT118B	142
ACT119	142
ACT407	141
ACT499A	141
ACT1008A	141
ACT1009A	142
ACT1046C	142
ACT1234PKT	139
ACT1290A	143
ACT1370	143
ACT81290	141
ACTB72	140
ACTB72A	140
ACTMAN2100	140
ACTR4131	139
ACTRB72	140
ACTRB96	140
ACTRR72	140
ACTRR96	140
ACTRY72	140
ACTRY96	140
ACTY72	140
ACTY72A	140
AF102	143
AHC21C	97
AHC21FC	97
AHC21MC	97
AHC21PC	97
AHC21PMC	97
AHC22D	97
AHC22FC	97
AHC22MC	97
AHC23C	97
AHC23FC	97
AHC23MC	97
AHC23PMC	97
AHC24C	96
AHC24FC	96

AHC24MC	96
AHC25C	96
AHC25FC	96
AHC25MC	96
AHC26C	96
AHC26FC	96
AHC26MC	96
AHC27C	97
AHC27FC	97
AHC28C	97
AHC28FC	97
AHC28MC	97
AHCC90C	155
AHCC91B	155
AHCCP90C	155
AHCCP97C	155
AHRB200	95
AIRHOSE35	96
AT105	79
AT109	79
AT109DGK	79
AT115	78
AT118	79
AT119	80
AT119DGK	80
AT123B	73
AT123BL	73
AT154R	81
AT157R	81
AT180C	83
AT184	77
AT185	82
AT192A	82
AT194A	82
AT195	82
AT200D	76
AT203	76
AT204	77
AT215	81
AT235MCA	75
AT321	74
AT351	74
AT370	74
AT380	74
AT401MCA	85
AT401MCKA	86
AT402MCA	85
AT402MCKA	86
AT403MCA	85
AT403MCKA	86
AT408	83
AT411A	83
AT415B	81
AT415CWMP	96
AT415T27MP	96
AT425R	84
AT435A	85
AT450B	84
AT450BP	86
AT460B	84
AT460BP	86
AT465B	83
AT475A	84
AT555B	72
AT570	73
AT700F	76
AT702	75
AT704	75
AT705B	75
AT738	76
AT760	72
AT760L	72

AT801MCA	78
AT811	78
AT1070A	80
AT1070RA	80
AT1300A	72
AT1300AL	72
AT2050	78
AT3000	77
AT5000	77
ATC500	72
AV1000A	122

B

B45CMP	58
B48CP	56
B58HLP	56
B65CMP	59
B75CMP	57
B85CMP	57
B85CTMP	57
B87CP	56
B95CLMP	59
B95CMP	58
B96CP	57
B240B	153
B945CMP	58
B960CMP	58
BADJC6	38
BADJC8	38
BADJC10	38
BADJC703	36
BAWP100	57
BB500	152
BBWDM67	40
BBWDM89	40
BBWDM810	40
BBWDM1011	40
BBWDM1012	40
BBWDM1113	40
BBWDM1213	40
BBWDM1214	40
BBWDM1415	40
BBWDM1417	40
BBWDM1617	40
BBWDM1719	40
BBWDM1819	40
BBWDM1921	40
BBWDM1922	40
BBWDM2022	40
BBWDM2123	40
BBWDM2224	40
BBWDM2326	40
BBWDM2426	40
BBWDM2427	40
BBWDM2430	40
BBWDM2528	40
BBWDM2730	40
BBWDM3032	40
BBWDM3436	40
BBWSM67	40
BBWSM89	40
BBWSM810	40
BBWSM911	40
BBWSM1011	40
BBWSM1012	40
BBWSM1113	40
BBWSM1213	40
BBWSM1214	40
BBWSM1314	40
BBWSM1415	40
BBWSM1417	40

BBWSM1516	40
BBWSM1617	40
BBWSM1719	40
BBWSM1819	40
BBWSM1921	40
BBWSM1922	40
BBWSM2022	40
BBWSM2122	40
BBWSM2123	40
BBWSM2224	40
BBWSM2326	40
BBWSM2426	40
BBWSM2427	40
BBWSM2528	40
BBWSM2730	40
BBWSM2732	40
BBWSM3032	40
BBWSM3436	40
BC45G	102
BCER7	62
BCER9	62
BCES7	62
BCE59	62
BCIR7	62
BCIR9	62
BCIS7	62
BCIS9	62
BD45G	102
BDG48CP	55
BDG57CP	54
BDG86CP	54
BDG86LMP	52
BDG88CP	54
BDG96LMP	52
BDG97LMP	52
BDG98CP	55
BDG311CP	53
BDG911CP	53
BDG916CP	53
BDG9645LMP	52
BDG9845CP	55
BDG91145CP	53
BDG91645CP	53
BDGAWP100	55
BDGCB8K	54
BDGCB9HK	54
BDGCT6K	54
BDGEC7	55
BDGLN6K	55
BDGLP7S	61
BDGLP10S	61
BDGPL200XLR	53
BDGPL300HG	53
BDGPL300LR	53
BDGPL400LMP	52
BDGPL410HG	53
BDGPL411HG	53
BDGPL412HG	53
BDGPL800	52
BDMAJ10	57
BDMCB6	56
BDMCB7	56
BDMCB8	56
BDMCT5	56
BDMCT6	56
BDMCT7	56
BDMLN6	57
BDMLN8	57
BDMLP7S	61
BDMLP10S	61
BDOE1012	39
BDOE1416	39

BLPLSMIM143 93
 BLPLSMIM146 93
 BLPLSMIM149 93
 BLPLSMIM150 93
 BLPLSMIM155 93
 BLPLSMIM387 88
 BLPLSMIM388 88
 BLPLSMIM389 88
 BLPLSMIM1210 90
 BLPLSMIM1211 90
 BLPLSMIM1212 90
 BLPLSMIM1213 90
 BLPLSMIM1214 90
 BLPLSMIM1215 90
 BLPLSMIM1216 90
 BLPLSMIM1217 90
 BLPLSMIM1218 90
 BLPLSMIM1219 90
 BLPLSMIM1221 90
 BLPLSMIM1222 90
 BLPLSMIM1224 90
 BLPLSMIM1226 90
 BLPLSMIM1227 90
 BLPLSMIM1229 90
 BLPLSMIM1230 90
 BLPLSMIM1232 90
 BLPLSMIM3417 91
 BLPLSMIM3418 91
 BLPLSMIM3419 91
 BLPLSMIM3420 91
 BLPLSMIM3421 91
 BLPLSMIM3422 91
 BLPLSMIM3423 91
 BLPLSMIM3424 91
 BLPLSMIM3425 91
 BLPLSMIM3426 91
 BLPLSMIM3427 91
 BLPLSMIM3428 91
 BLPLSMIM3429 91
 BLPLSMIM3430 91
 BLPLSMIM3431 91
 BLPLSMIM3432 91
 BLPLSMIM3433 91
 BLPLSMIM3434 91
 BLPLSMIM3435 91
 BLPLSMIM3436 91
 BLPLSMIM3437 91
 BLPLSMIM3438 91
 BLPLSMIM3440 91
 BLPLSMIM3441 91
 BLPLSMIM3442 91
 BLPLSMIM3443 91
 BLPLSMIM3444 91
 BLPLSMIM3445 91
 BLPLSMIM3446 91
 BLPLSMIM3447 91
 BLPLSMIM3448 91
 BLPLSMIM3449 91
 BLPLSMIM3450 91
 BLPLSMIM3455 91
 BLPLSMIM3810 88
 BLPLSMIM3811 88
 BLPLSMIM3812 88
 BLPLSMIM3813 88
 BLPLSMIM3814 88
 BLPLSMIM3815 88
 BLPLSMIM3816 88
 BLPLSMIM3817 88
 BLPLSMIM3818 88
 BLPLSMIM3819 88
 BLPLW3415 33
 BLPP140 21

BLPP141 21
 BLPP142 21
 BLPP143 21
 BLPP144 21
 BLPP381 27
 BLPP382 27
 BLPP383 27
 BLPP384 27
 BLPPB0 49
 BLPPB1 49
 BLPPB2 49
 BLPPB3 49
 BLPPB704 130
 BLPPD141 21
 BLPPD142 21
 BLPPD143 21
 BLPPD381 27
 BLPPD382 27
 BLPPD383 27
 BLPPD384 27
 BLPPS141 21
 BLPPS142 21
 BLPPTA3438 27
 BLPPTEXT3 27
 BLPPTS12 27
 BLPPTS34 27
 BLPPTS38 27
 BLPPTS58 27
 BLPPTS716 27
 BLPPTS916 27
 BLPPTS1116 27
 BLPPTSM8 26
 BLPPTSM9 26
 BLPPTSM10 26
 BLPPTSM11 26
 BLPPTSM12 26
 BLPPTSM13 26
 BLPPTSM14 26
 BLPPTSM15 26
 BLPPTSM16 26
 BLPPTSM17 26
 BLPPTSM18 26
 BLPPTSM19 26
 BLPPTSS3822 13
 BLPS12 31
 BLPS121 29
 BLPS381 23
 BLPS1212 29
 BLPS1234 29
 BLPS1238 29
 BLPS1258 29
 BLPS1278 29
 BLPS1412 18
 BLPS1414 18
 BLPS1438 18
 BLPS1458 18
 BLPS3812 23
 BLPS3814 23
 BLPS3834 23
 BLPS3838 23
 BLPS3858 23
 BLPS3878 23
 BLPS12516 29
 BLPS12716 29
 BLPS12916 29
 BLPS14316 18
 BLPS14516 18
 BLPS14532 18
 BLPS14716 18
 BLPS14732 18
 BLPS14916 18
 BLPS14932 18

BLPS38516 23
 BLPS38716 23
 BLPS38916 23
 BLPS81414 18
 BLPS81438 18
 BLPS121116 29
 BLPS121316 29
 BLPS121516 29
 BLPS141132 18
 BLPS381116 23
 BLPS381316 23
 BLPS381516 23
 BLPS814516 18
 BLPSB12114 29
 BLPSB12118 29
 BLPSB121116 29
 BLPSB121316 29
 BLPSH1238 31
 BLPSIM121 90
 BLPSIM341 92
 BLPSIM1212 90
 BLPSIM1234 90
 BLPSIM1238 90
 BLPSIM1258 90
 BLPSIM1278 90
 BLPSIM3434 92
 BLPSIM3478 92
 BLPSIM3812 88
 BLPSIM3814 88
 BLPSIM3834 88
 BLPSIM3838 88
 BLPSIM3858 88
 BLPSIM12716 90
 BLPSIM12916 90
 BLPSIM38516 88
 BLPSIM38716 88
 BLPSIM38916 88
 BLPSIM121116 90
 BLPSIM121316 90
 BLPSIM121516 90
 BLPSIM341116 92
 BLPSIM341316 92
 BLPSIM341516 92
 BLPSIM381116 88
 BLPSIMB342 92
 BLPSIMB12114 90
 BLPSIMB12118 90
 BLPSIMB34112 92
 BLPSIMB34114 92
 BLPSIMB34118 92
 BLPSIMB34134 92
 BLPSIMB34138 92
 BLPSIMB34158 92
 BLPSIMB34178 92
 BLPSIMB121116 90
 BLPSIMB121516 90
 BLPSIMB121716 90
 BLPSIMB341116 92
 BLPSIMB341316 92
 BLPSIMB341516 92
 BLPSIMB341716 92
 BLPSIMB341916 92
 BLPSIMB3411116 92
 BLPSIMB3411316 92
 BLPSIMB3411516 92
 BLPSM128 28
 BLPSM129 28
 BLPSM143.5 18
 BLPSM144 18
 BLPSM144.5 18
 BLPSM145 18
 BLPSM145.5 18

BLPSM146 18
 BLPSM147 18
 BLPSM148 18
 BLPSM149 18
 BLPSM386 23
 BLPSM387 23
 BLPSM388 23
 BLPSM389 23
 BLPSM1210 28
 BLPSM1211 28
 BLPSM1212 28
 BLPSM1213 28
 BLPSM1214 28
 BLPSM1215 28
 BLPSM1216 28
 BLPSM1217 28
 BLPSM1218 28
 BLPSM1219 28
 BLPSM1220 28
 BLPSM1221 28
 BLPSM1222 28
 BLPSM1223 28
 BLPSM1224 28
 BLPSM1227 28
 BLPSM1230 28
 BLPSM1232 28
 BLPSM1234 28
 BLPSM1236 28
 BLPSM1410 18
 BLPSM1411 18
 BLPSM1412 18
 BLPSM1413 18
 BLPSM1414 18
 BLPSM3810 23
 BLPSM3811 23
 BLPSM3812 23
 BLPSM3813 23
 BLPSM3814 23
 BLPSM3815 23
 BLPSM3816 23
 BLPSM3817 23
 BLPSM3818 23
 BLPSM3819 23
 BLPSM3820 23
 BLPSM3821 23
 BLPSM3822 23
 BLPSM3823 23
 BLPSM3824 23
 BLPSMIM117 93
 BLPSMIM118 93
 BLPSMIM119 93
 BLPSMIM120 93
 BLPSMIM121 93
 BLPSMIM122 93
 BLPSMIM123 93
 BLPSMIM124 93
 BLPSMIM125 93
 BLPSMIM126 93
 BLPSMIM127 93
 BLPSMIM128 93
 BLPSMIM129 93
 BLPSMIM130 93
 BLPSMIM131 93
 BLPSMIM132 93
 BLPSMIM133 93
 BLPSMIM134 93
 BLPSMIM135 93
 BLPSMIM136 93
 BLPSMIM137 93
 BLPSMIM138 93
 BLPSMIM139 93
 BLPSMIM140 93

BLPSMIM141 93
 BLPSMIM142 93
 BLPSMIM143 93
 BLPSMIM144 93
 BLPSMIM145 93
 BLPSMIM146 93
 BLPSMIM147 93
 BLPSMIM148 93
 BLPSMIM149 93
 BLPSMIM150 93
 BLPSMIM151 93
 BLPSMIM152 93
 BLPSMIM153 93
 BLPSMIM154 93
 BLPSMIM155 93
 BLPSMIM156 93
 BLPSMIM157 93
 BLPSMIM158 93
 BLPSMIM159 93
 BLPSMIM160 93
 BLPSMIM163 93
 BLPSMIM165 93
 BLPSMIM166 93
 BLPSMIM167 93
 BLPSMIM168 93
 BLPSMIM169 93
 BLPSMIM387 88
 BLPSMIM388 88
 BLPSMIM389 88
 BLPSMIM1210 89
 BLPSMIM1211 89
 BLPSMIM1212 89
 BLPSMIM1213 89
 BLPSMIM1214 89
 BLPSMIM1215 89
 BLPSMIM1216 89
 BLPSMIM1217 89
 BLPSMIM1218 89
 BLPSMIM1219 89
 BLPSMIM1221 89
 BLPSMIM1222 89
 BLPSMIM1213 89
 BLPSMIM1214 89
 BLPSMIM1215 89
 BLPSMIM1216 89
 BLPSMIM1217 89
 BLPSMIM1218 89
 BLPSMIM1219 89
 BLPSMIM1221 89
 BLPSMIM1222 89
 BLPSMIM1223 89
 BLPSMIM1224 89
 BLPSMIM1227 89
 BLPSMIM1230 89
 BLPSMIM1232 89
 BLPSMIM1237 89
 BLPSMIM1238 89
 BLPSMIM1239 89
 BLPSMIM1240 89
 BLPSMIM1241 89
 BLPSMIM1242 89
 BLPSMIM1243 89
 BLPSMIM1244 89
 BLPSMIM1245 89
 BLPSMIM1246 89
 BLPSMIM1247 89
 BLPSMIM1248 89
 BLPSMIM1249 89
 BLPSMIM1250 89
 BLPSMIM1251 89
 BLPSMIM1252 89
 BLPSMIM1253 89
 BLPSMIM1254 89
 BLPSMIM1255 89
 BLPSMIM1256 89
 BLPSMIM1257 89
 BLPSMIM1258 89
 BLPSMIM1259 89
 BLPSMIM1260 89
 BLPSMIM1261 89
 BLPSMIM1262 89
 BLPSMIM1263 89
 BLPSMIM1264 89
 BLPSMIM1265 89
 BLPSMIM1266 89
 BLPSMIM1267 89
 BLPSMIM1268 89
 BLPSMIM1269 89
 BLPSMIM1270 89
 BLPSMIM1271 89
 BLPSMIM1272 89
 BLPSMIM1273 89
 BLPSMIM1274 89
 BLPSMIM1275 89
 BLPSMIM1276 89
 BLPSMIM1277 89
 BLPSMIM1278 89
 BLPSMIM1279 89
 BLPSMIM1280 89
 BLPSMIM1281 89
 BLPSMIM1282 89
 BLPSMIM1283 89
 BLPSMIM1284 89
 BLPSMIM1285 89
 BLPSMIM1286 89
 BLPSMIM1287 89
 BLPSMIM1288 89
 BLPSMIM1289 89
 BLPSMIM1290 89
 BLPSMIM1291 89
 BLPSMIM1292 89
 BLPSMIM1293 89
 BLPSMIM1294 89
 BLPSMIM1295 89
 BLPSMIM1296 89
 BLPSMIM1297 89
 BLPSMIM1298 89
 BLPSMIM1299 89
 BLPSMIM1300 89
 BLPSMIM1301 89
 BLPSMIM1302 89
 BLPSMIM1303 89
 BLPSMIM1304 89
 BLPSMIM1305 89
 BLPSMIM1306 89
 BLPSMIM1307 89
 BLPSMIM1308 89
 BLPSMIM1309 89
 BLPSMIM1310 89
 BLPSMIM1311 89
 BLPSMIM1312 89
 BLPSMIM1313 89
 BLPSMIM1314 89
 BLPSMIM1315 89
 BLPSMIM1316 89
 BLPSMIM1317 89
 BLPSMIM1318 89
 BLPSMIM1319 89
 BLPSMIM1320 89
 BLPSMIM1321 89
 BLPSMIM1322 89
 BLPSMIM1323 89
 BLPSMIM1324 89
 BLPSMIM1325 89
 BLPSMIM1326 89
 BLPSMIM1327 89
 BLPSMIM1328 89
 BLPSMIM1329 89
 BLPSMIM1330 89
 BLPSMIM1331 89
 BLPSMIM1332 89
 BLPSMIM1333 89
 BLPSMIM1334 89
 BLPSMIM1335 89
 BLPSMIM1336 89
 BLPSMIM1337 89
 BLPSMIM1338 89
 BLPSMIM1339 89
 BLPSMIM1340 89
 BLPSMIM1341 89
 BLPSMIM1342 89
 BLPSMIM1343 89
 BLPSMIM1344 89
 BLPSMIM1345 89
 BLPSMIM1346 89
 BLPSMIM1347 89
 BLPSMIM1348 89
 BLPSMIM1349 89
 BLPSMIM1350 89
 BLPSMIM1351 89
 BLPSMIM1352 89
 BLPSMIM1353 89
 BLPSMIM1354 89
 BLPSMIM1355 89
 BLPSMIM1356 89
 BLPSMIM1357 89
 BLPSMIM1358 89
 BLPSMIM1359 89
 BLPSMIM1360 89
 BLPSMIM1361 89
 BLPSMIM1362 89
 BLPSMIM1363 89
 BLPSMIM1364 89
 BLPSMIM1365 89
 BLPSMIM1366 89
 BLPSMIM1367 89
 BLPSMIM1368 89
 BLPSMIM1369 89
 BLPSMIM1370 89
 BLPSMIM1371 89
 BLPSMIM1372 89
 BLPSMIM1373 89
 BLPSMIM1374 89
 BLPSMIM1375 89
 BLPSMIM1376 89
 BLPSMIM1377 89
 BLPSMIM1378 89
 BLPSMIM1379 89
 BLPSMIM1380 89
 BLPSMIM1381 89
 BLPSMIM1382 89
 BLPSMIM1383 89
 BLPSMIM1384 89
 BLPSMIM1385 89
 BLPSMIM1386 89
 BLPSMIM1387 89
 BLPSMIM1388 89
 BLPSMIM1389 89
 BLPSMIM1390 89
 BLPSMIM1391 89
 BLPSMIM1392 89
 BLPSMIM1393 89
 BLPSMIM1394 89
 BLPSMIM1395 89
 BLPSMIM1396 89
 BLPSMIM1397 89
 BLPSMIM1398 89
 BLPSMIM1399 89
 BLPSMIM1400 89

BLPSMIM3442 91
 BLPSMIM3443 91
 BLPSMIM3444 91
 BLPSMIM3445 91
 BLPSMIM3446 91
 BLPSMIM3447 91
 BLPSMIM3448 91
 BLPSMIM3449 91
 BLPSMIM3450 91
 BLPSMIM3452 91
 BLPSMIM3454 91
 BLPSMIM3455 91
 BLPSMIM3456 91
 BLPSMIM3457 91
 BLPSMIM3458 91
 BLPSMIM3459 91
 BLPSMIM3460 91
 BLPSMIM3463 91
 BLPSMIM3465 91
 BLPSMIM3810 88
 BLPSMIM3811 88
 BLPSMIM3812 88
 BLPSMIM3813 88
 BLPSMIM3814 88
 BLPSMIM3815 88
 BLPSMIM3816 88
 BLPSMIM3817 88
 BLPSMIM3818 88
 BLPSMIM3819 88
 BLPSPS1216 30
 BLPSPS1221 30
 BLPSPS1258 30
 BLPSPS3816 25
 BLPSPS3821 25
 BLPSPS3858 25
 BLPSPS121316 30
 BLPSPS381316 25
 BLPSQB1 49
 BLPSQB2 49
 BLPSTHD144 20
 BLPSTHD388 26
 BLPSTHD1215 31
 BLPSTHD3418 33
 BLPSTWR4 43
 BLPSTWR6 43
 BLPT146TP 22
 BLPT147TP 22
 BLPT148TP 22
 BLPT149TP 22
 BLPT1220 31
 BLPT1225 31
 BLPT1230 31
 BLPT1240 31
 BLPT1245 31
 BLPT1250 31
 BLPT1255 31
 BLPT1255TP 30
 BLPT1260 31
 BLPT1260TP 30
 BLPT1410TP 22
 BLPT1415TP 22
 BLPT1420TP 22
 BLPT1425TP 22
 BLPT1427TP 22
 BLPT1430TP 22
 BLPT3810TP 26
 BLPT3815TP 26
 BLPT3820TP 26
 BLPT3825TP 26
 BLPT3827TP 26
 BLPT3830TP 26

BLPT3840TP	26
BLPT3845TP	26
BLPT3850TP	26
BLPT3855TP	26
BLPTB10TP	49
BLPTB15TP	49
BLPTB20TP	49
BLPTB25TP	49
BLPTB30TP	49
BLPTE144	18
BLPTE145	18
BLPTE146	18
BLPTE147	18
BLPTE148	18
BLPTE384	23
BLPTE385	23
BLPTE386	23
BLPTE387	23
BLPTE388	23
BLPTE1210	30
BLPTE1212	30
BLPTE1214	30
BLPTE1216	30
BLPTE1218	30
BLPTE1220	30
BLPTE1222	30
BLPTE1224	30
BLPTE3810	23
BLPTE3811	23
BLPTE3812	23
BLPTE3814	23
BLPTE3816	23
BLPTE3818	23
BLPTE3820	23
BLPTHSM0142	21
BLPTHSM0143	21
BLPTHSM0144	21
BLPTHSM0145	21
BLPTHSM0146	21
BLPTHSM0147	21
BLPTHSM0148	21
BLPTHSM0149	21
BLPTHSM01410	21
BLPTHSM01425	21
BLPTL1220	32
BLPTL1225	32
BLPTL1227	32
BLPTL1230	32
BLPTL1240	32
BLPTL1245	32
BLPTL1250	32
BLPTL1255	32
BLPTL1260	32
BLPTMBS1414	20
BLPTMBS3814	26
BLPTS0148	21
BLPTS01410	21
BLPTS01415	21
BLPTS01420	21
BLPTS01425	21
BLPTS01427	21
BLPTS01430	21
BLPTS01440	21
BLPTS01445	21
BLPTS01447	21
BLPTS01450	21
BLPTS3810	27
BLPTS3815	27
BLPTS3820	27
BLPTS3825	27
BLPTS3827	27
BLPTS3830	27

BLPTS3840	27
BLPTS3845	27
BLPTS3850	27
BLPTS3855	27
BLPTS3860	27
BLPSSC43	11
BLPTXK1.5	19
BLPTXK2	19
BLPTXK3	19
BLPTXK4	19
BLPTXK6	19
BLPUJ12	31
BLPUJ14	20
BLPUJ34	33
BLPUJ38	25
BLPXZN144	22
BLPXZN145	22
BLPXZN146	22
BLPXZN148	22
BLPXZN1410	22
BLPXZN1412	22
BLPXZNM125	32
BLPXZNM126	32
BLPXZNM128	32
BLPXZNM0384	28
BLPXZNM0385	28
BLPXZNM0386	28
BLPXZNM0388	28
BLPXZNM1210	32
BLPXZNM1212	32
BLPXZNM1214	32
BLPXZNM1216	32
BLPXZNM03810	28
BLPXZNM03812	28
BLWM12	43
BLWM14	43
BLWM17	43
BLWM19	43
BLWSM9	38
BLWTS9	38
BMPEC5	58
BMPL1000	52
BMPLM3	112
BMPLM5	112
BMPM3	112
BMPM5	112
BMPM8	112
BOER8	41
BOER10	41
BOER12	41
BOER14	41
BOER16	41
BOER18	41
BOER20	41
BOER22	41
BOER24	41
BOER26	41
BOER28	41
BOER30	41
BOER32	41
BOER704	36
BOER708	36
BOERF10A	41
BOERF12A	41
BOERF14A	41
BOERF16A	41
BOERF18A	41
BOERF20A	41
BOERF22A	41
BOERF24A	41
BOERF708A	37
BOERFLCG10	42

BOERFLCG12	42
BOERFLCG14	42
BOERFLCG16	42
BOERFLCG18	42
BOERFLCG20	42
BOERFLCG22	42
BOERFLCG24	42
BOERFLCG708	38
BOERM6	41
BOERM7	41
BOERM8	41
BOERM9	41
BOERM10	41
BOERM11	41
BOERM12	41
BOERM13	41
BOERM14	41
BOERM15	41
BOERM16	41
BOERM17	41
BOERM18	41
BOERM19	41
BOERM21	41
BOERM22	41
BOERM24	41
BOERM25	41
BOERM704	36
BOERM712	36
BOERMF8A	41
BOERMF9A	41
BOERMF10A	41
BOERMF11A	41
BOERMF12A	41
BOERMF13A	41
BOERMF14A	41
BOERMF15A	41
BOERMF16A	41
BOERMF17A	41
BOERMF18A	41
BOERMF19A	41
BOERMF712A	37
BOERMFLCG8	42
BOERMFLCG9	42
BOERMFLCG10	42
BOERMFLCG11	42
BOERMFLCG12	42
BOERMFLCG13	42
BOERMFLCG14	42
BOERMFLCG15	42
BOERMFLCG16	42
BOERMFLCG17	42
BOERMFLCG18	42
BOERMFLCG19	42
BOERMFLCG712	37
BOERMS8	40
BOERMS9	40
BOERMS10	40
BOERMS11	40
BOERMS12	40
BOERMS13	40
BOERMS14	40
BOERMS15	40
BOERMS16	40
BOERMS17	40
BOERMS18	40
BOERMS19	40
BOERMS712	37
BOERMSF8	40
BOERMSF9	40
BOERMSF10	40
BOERMSF11	40
BOERMSF12	40

BOERMSF13	40
BOERMSF14	40
BOERMSF15	40
BOERMSF16	40
BOERMSF17	40
BOERMSF18	40
BOERMSF19	40
BOERMSF712	36
BOERS10	40
BOERS12	40
BOERS14	40
BOERS16	40
BOERS18	40
BOERS20	40
BOERS22	40
BOERS24	40
BOERS708	37
BOERSF10	41
BOERSF12	41
BOERSF14	41
BOERSF16	41
BOERSF18	41
BOERSF20	41
BOERSF22	41
BOERSF24	41
BOERSF708	37
BP5T-1R	66
BP5T-1	67
BP10002-I-DTT	69
BP10ST-I	67
BP10T-2R	66
BP10T-I	67
BP50T-2R	66
BP50T-I	67
BP100T-3R	66
BP100T-I	67
BP200T-3R	66
BP200T-I	67
BP300T-4R	66
BP300T-I	67
BP501-I-DTT	69
BP501NMRMH	66
BP600T-4R	66
BP600T-I*	67
BP602NMRMH	66
BP1001-O-DTT	69
BP1002CF3	68
BP1002NMRMH	66
BP2003NMRMH	66
BP2401CI3	68
BP2502-I-DTT	69
BP2502NMRMH	66
BP2503CF3	68
BP2503-F-DTT	69
BP3403NMRMH	66
BP6004-F-DTT	69
BP8004NMRMH	66
BP15005NMRMH	66
BPB4	101
BPB8	101
BPB12	101
BPB16	101
BPB24	101
BPB32	101
BPB40	101
BPB48	101
BPBOX18	5
BPECT1	132
BPL501	52
BPN8B	100
BPN12B	100
BPN16B	100

BPN24B	100
BPN32B	100
BPRFPT10	27
BPRFR938	24
BPRFR938SG	24
BPRSR940	30
BPRSR940SG	30
BPRSR942	33
BPRT936	19
BPRT936SG	19
BPTHM08	43
BPTHM09	43
BPTHM10	43
BPTHM11	43
BPTHM12	43
BPTHM13	43
BPTHM14	43
BPTOTE	5
BPWORKBENCH	161
BSGD75F4B	46
BSGD75F4R	46
BSGD75F4Y	46
BSGD75PH0B	46
BSGD75PHOR	46
BSGD75PHOR	46
BSGD75PHOR	46
BSGD75PHOY	46
BSGD75S3B	46
BSGD75S3R	46
BSGD75S3Y	46
BSGD100PH0B	46
BSGD100PHOR	46
BSGD100PH0Y	46
BSGD100PH1B	46
BSGD100PH1R	46
BSGD100PH1Y	46
BSGD100PH2B	46
BSGD100PH2R	46
BSGD100PH2Y	46
BSGD100S4B	46
BSGD100S4R	46
BSGD100S4Y	46
BSGD125F5B	46
BSGD125F5R	46
BSGD125F5Y	46
BSGD125F6B	46
BSGD125F6Y	46
BSGD125S4B	46
BSGD125S4R	46
BSGD125S4Y	46
BSGD125S5B	46
BSGD125S5R	46
BSGD125S5Y	46
BSGD150F6B	46
BSGD150F6R	46
BSGD150F6Y	46
BSGD150F8B	46
BSGD150F8R	46
BSGD150F8Y	46
BSGD150PH0B	46
BSGD150PHOR	46
BSGD150PH0Y	46
BSGD150PH1B	46
BSGD150PH1R	46
BSGD150PH1Y	46
BSGD150PH2B	46
BSGD150PH2R	46
BSGD150PH2Y	46
BSGD150PH3B	46
BSGD150PH3R	46
BSGD150PH3Y	46
BSGD150S4B	46
BSGD150S4R	46

BSGD150S4Y	46
BSGD150S5B	46
BSGD150S5R	46
BSGD150S5Y	46
BSGD175F8B	46
BSGD175F8R	46
BSGD175F8Y	46
BSGD200PH1B	46
BSGD200PH1R	46
BSGD200PH1Y	46
BSGD200PH2B	46
BSGD200PH2R	46
BSGD200PH2Y	46
BSGD200PH3B	46
BSGD200PH3R	46
BSGD200PH3Y	46
BSGD250F6B	46
BSGD250F6R	46
BSGD250F6Y	46
BSGD250PH1B	46
BSGD250PH1R	46
BSGD250PH1Y	46
BSGD250PH2B	46
BSGD250PH2R	46
BSGD250PH2Y	46
BSGD250S4B	46
BSGD250S4R	46
BSGD250S4Y	46
BSGD300PH1B	46
BSGD300PH1R	46
BSGD300PH1Y	46
BSGD300PH2B	46
BSGD300PH2R	46
BSGD300PH2Y	46
BSGDM38F6	48
BSGDM38PH2	48
BSGDM38PZ2	48
BSGDM65F2	48
BSGDM65PH00	48
BSGDM65PZ00	48
BSGDM75F3	48
BSGDM75F5	48
BSGDM75PH0	48
BSGDM75PH1	48
BSGDM75PZ0	48
BSGDM75PZ1	48
BSGDM75TX6	48
BSGDM75TX7	48
BSGDM75TX8	48
BSGDM75TX9	48
BSGDM100F3	48
BSGDM100F5	48
BSGDM100F6	48
BSGDM100PH0	48
BSGDM100PH1	48
BSGDM100PH2	48
BSGDM100PZ0	48
BSGDM100PZ1	48
BSGDM100PZ2	48
BSGDM100TX10	48
BSGDM100TX15	48
BSGDM100TX20	48
BSGDM100TX25	48
BSGDM100TX27	48
BSGDM100TX30	48
BSGDM100TX40	48
BSGDM150F3	48
BSGDM150F5	48
BSGDM150F6	48
BSGDM150F8	48
BSGDM150PH0	48
BSGDM150PH1	48

R
RBZ605 38
RBZ810 42
RBZ1214 42
RBZ1618 42
RBZ2022 42
RBZ2428 42
RBZM78 42
RBZM605 38
RBZM910 42
RBZM1112 42
RBZM1314 42
RBZM1517 42
RBZM1618 42
RBZM1921 42
RC40C 151
RC50C 151
RC980 151
RM130 151
RTEMPB3A 136
RULER12BSQ 113

S
SBT26 150
SDM11KT 130
SDM32KT 130
SKRSST4107 5
SKRWT4008 5
SKRWT4008B 5
SNP2A 104
SQUAREB12 113
SQUAREB45 113
SQUAREB90 113
SQUAREB180 113
SQUARECOMB12 113
SVT275 144
SVTAB1400 143
SXLBP3 30
SXLBP6 30
SXLBP10 30

T
TBS200A 130
TC28B1 107
TC28C 107
TC123C 107
TC123C1 107
TC123CR 107
TC123CRH 107
TEMP10 141
TF5A 107
TF275A 107
TF528D 106
TFM5A 107
TFM428 107
TL100A 112
TLT5 135
TLT6 135
TLT7 135
TLT8000 135
TLT8003 135
TPGDL1000 144
TPGIF1600 144
TPGP120 144
TPM100 112
TT12KT 137
TZK5 127
TZK7 127

U
UIM125 119
UIM225 119
UIM325 119
UKBU10 106
UKBU50PK 106
UPT2FL 120
UPT15 120
UPT35 120
UPT50A 121
UPT65 121
US710 103
US711 103
US712 103
USS103 103

V
VAC201 147
VGP12406 61
VGP12412 61
VGP12418 61
VGP12424 61
VGP12509 62
VGP12808 62
VGP18110 62
VGP22406 61
VGP22412 61
VGP22418 61
VGP22424 61
VT1A 145
VT14 145

W
WE200A 123
WE200A1 123
WE200A2 123
WT1001-6 60
WT1001-8 60
WT1003-6 60
WT1014-6 60
WT1014-7 60
WT1014-8 60
WT1017C-6 60
WT5403-8 60
WT5414-9 60
WT8627-10 60

Y
YA52PBSQC 128
YA109C 155
YA160A 119
YA261A 95
YA262A 95
YA263A 95
YA328A 112
YA427B 122
YA444A-1 105
YA444B 105
YA481 7
YA482 7
YA483 7
YA484 7
YA486 7
YA512 159
YA580A 105
YA580A-1 105
YA581A 105
YA581A-1 105

YA714D 159
YA728A 148
YA734A 148
YA745A 149
YA750 149
YA751 149
YA752 149
YA772B 149
YA778 160
YA801 149
YA824ASTR 133
YA824C 133
YA879A 102
YA900 102
YA1050B 96
YA1055B 129
YA1228 160
YA1544A 131
YA1642A 158
YA1707 158
YA1715 158
YA1716 158
YA2440 131
YA2612B 138
YA3000C 146
YA3100 146
YA3202 133
YA3500 146
YA4000B 154
YA4274 147
YA4275 147
YA4280 123
YA4282 123
YA4603 123
YA5100B 115
YA6160 144
YA6910 136
YA7500 149
YA8005 133
YA8230 151
YA8610B 153
YA9329A 131
YA9350B 150
YA76462 137
YA76562 136
YA105020 129
YAS203A 95

Showing Millimeter Sizes, Fractional and Decimal Inch Sizes, and Drill Number Sizes

Note: To convert from inches to millimeters, multiply by 25.4; to convert from millimeters to inches, multiply by 0.03937

Table with 21 columns: M, DE, F, DN, M, DE, F, DN, M, DE, F, DN, M, DE, F, DN, M, DE, F, M, DE, F. Rows contain various drill bit sizes and their conversions.

M = Millimeters, DE = Decimal Equivalents, F = Fractional, DN = Drill Number/Letter